

STEEL TRUSS MINI STORAGE RIGID FRAME

STEEL TRUSS MINI STORAGE RIGID FRAME



1117 Solitude Dr • Van Buren, AR 72956 • 800-255-7624

STEEL TRUSS FRAME, U.S. PATENT NO.5577353

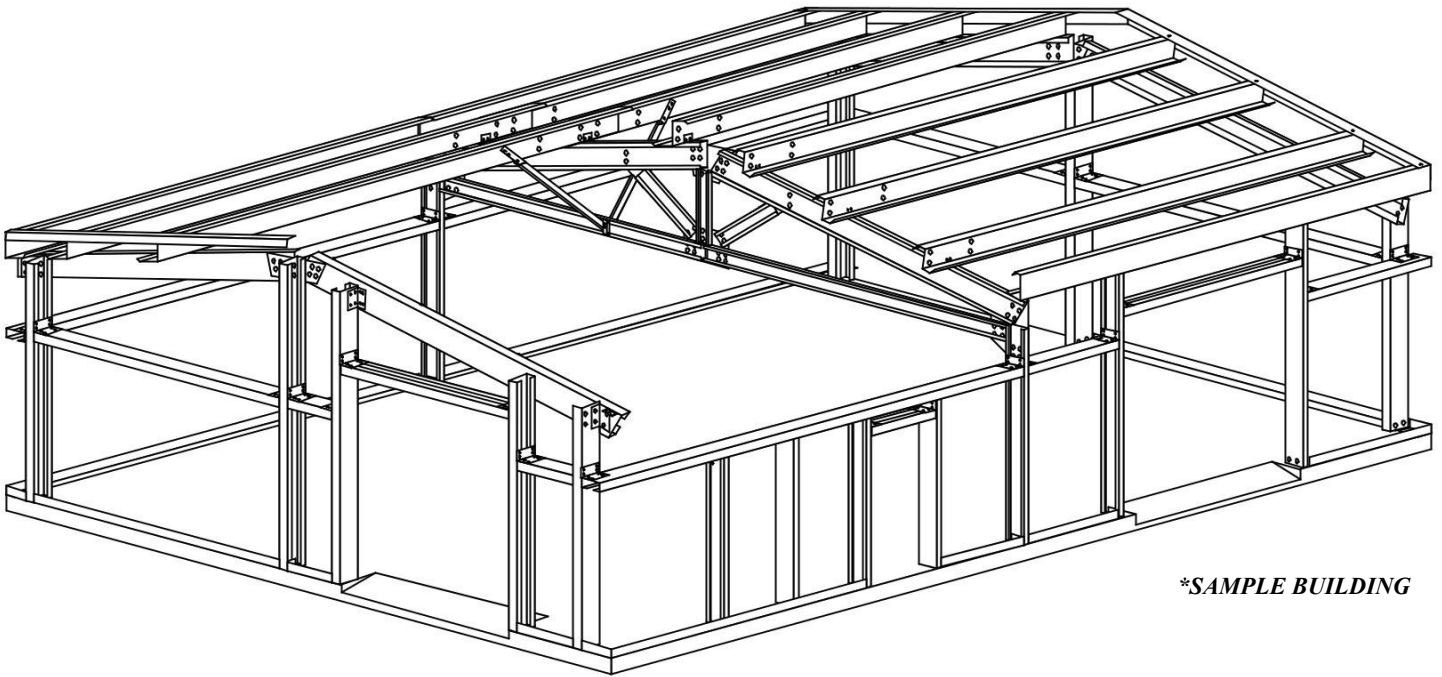

**SAMPLE BUILDING*

***ERECTION AND FABRICATION FIELD MANUAL
FOR STEEL TRUSS FRAME BUILDINGS***

REVISION 3

***REVIEW THOROUGHLY BEFORE BEGINNING
BUILDING ERECTION
IMPORTANT INFORMATION INSIDE***

SIMPSON STEEL BUILDING COMPANY • 1117 SOLITUDE DRIVE • VAN BUREN, ARKANSAS 72956 • 800-255-7624

INDEX

SIMPSON STEEL BUILDING COMPANY HISTORY	2
SHORTAGES AND BACKCHARGES	3
SHORTAGES AND BACKCHARGES CONTINUED	4
INTRODUCTION AND PREFACE	5
HARDWARE DETAILS	6-8
SECTION 1	
GENERAL FOUNDATION AND BUILDING ANCHORAGE / BASIC CHECKLIST FOR BUILDING ERECTION	9
BASIC CHECKLIST FOR BUILDING ERECTION WITH OVERHANG	10
BUILDING COMPONENT DEFINITIONS / 4 PAGES GENERAL FOUNDATION INFORMATION	11-14
FOUNDATION AND BUILDING ANCHORAGE	15
FOUNDATION CHECKING PROCEDURES	16
ANCHOR BOLT SETTINGS	17
SECTION 2	
PRE-ERECTION / ACCESS TO SITE	18
UNLOADING OPERATIONS / 2 PAGES	19-20
LOCATION OF BUILDING PARTS	21
SECTION 3	
UNLOADING, HANDLING AND STORAGE MATERIALS / STRUCTURAL	22
UNLOADING	23
CABLE TENSION AND HOOK HEIGHT	24
WALL AND ROOF PANELS / 2 PAGES	25-26
SECTION 4	
STRUCTURAL FRAMING PRECAUTIONS	27
ERECTION OF PRIMARY AND SECONDARY STRUCTURES / GENERAL INFORMATION	28
RECOMMENDED TOOLS	29
ATTACHING COLUMNS TO THE CONCRETE	30
RAISING STEEL TRUSS FRAMES / 4 PAGES	31-34
TYPICAL TRUSS FRAME STRUCTURE	35
STEEL TRUSS FRAME OVERHANG	36
OVERHANG DETAIL / 2 PAGES	37-38
TYPICAL SECONDARY FRAMING CONNECTIONS / 2 PAGES	39-40
RAKE / GABLE ANGLE WITH OVERHANG	41
SHEETING	42
" PBR " PANEL	43
FASTENER INSTALLATION & ATTACHMENT DETAIL	44
FASTENER LAYOUT / PLACEMENT	45
SCREW ALIGNMENT / 2 PAGES	46-47
ALIGNING THE GIRTS	48
WALL INSULATION AND INSTALLATION / 2 PAGES	49-50
INSTALLATION OF WALL PANELS	51
ROOF INSULATION / 3 PAGES	52-54
SAFETY PRECAUTIONS FOR ROOFING WORK	55
SAFETY PRECAUTIONS FOR SLICK PANELS	56
PREPARING THE EAVE / 2 PAGES	57-58
INSTALLATION OF FIRST ROOF PANEL	59
ROOF SHEETING SEQUENCE	60
INSTALLATION OF ROOF PANELS	61
SECTION AT EAVE (NO GUTTER)	62
SEALING THE ROOF PANEL SIDELAP	63
SEALING THE EAVE	64
DIE FORMED RIDGE INSTALLATION	65
INSTALLATION OF FINAL PANEL	66
SKYLIGHT INSTALLATION	67
" PBR " PANEL TRANSLUCENT ROOF PANELS	68
INSULATED TRANSLUCENT PANEL AND UL-90 ASSEMBLY	69
FLASHING, GUTTER AND TRIM	70
TRIM DETAIL	71
RAKE TRIM ENDCAP INSTALLATION	72
EAVE FLASHING AND GUTTER INSTALLATION	73
INSTALLING GUTTER CLIPS	74
DOWNSPOUT DETAIL	75
PEAK BOX INSTALLATION	76
GABLE OVERHANG TRIM DETAIL	77
EAVE OVERHANG TRIM DETAIL	78
CAULK AND LAP DETAILS	79
PERSONNEL DOOR FRAMED OPENING	80
OVERHEAD DOOR FRAMED OPENING IN SIDEWALL	81
HORIZONTAL SLIDE WINDOW IN " PBR " PANEL WALL	82
HORIZONTAL SLIDE WINDOW IN " A " PANEL WALL	83
WAINSCOT DETAIL WITH TRIM AT CORNER ON SIDEWALL	84
FRAMED OPENING JAMB TRIM DETAIL	85
ANCHOR BOLT TEMPLATE (2 BOLT)	86
ANCHOR BOLT TEMPLATE (4 BOLT)	87
CABLE BRACING	88-91
SECTION 5	
LEAN-TO FOUNDATION	92-93
CONTINUOUS LEAN-TO AT 3:12 PITCH	94-96
OFF EAVE LEAN-TO AT 1:12 PITCH	97-99
UNDER EAVE LEAN-TO	100-104
WRAP AROUND PORCH AT 3:12 PITCH	105-109

HISTORY AND PHILOSOPHY

THE STEEL TRUSS DESIGN WAS ENGINEERED TO COMPETE HEAD ON WITH THE POLE BARN. IN THE PAST, OUR INDUSTRY HAS LOST ALL OF THE 40 FOOT WIDE AND UNDER BUSINESS TO THE WOOD FRAME POLE BARNS. WITH THE TRUSS, WE CAN OFFER A FAR SUPERIOR STRUCTURE AT THE SAME PRICE OR SLIGHTLY HIGHER PRICE THAN EVEN THE CHEAP LUMBER YARD PACKAGES.

THE VOLUME OF BUSINESS THAT WE DO ENABLES US TO OFFER THE CADILLAC OF THE INDUSTRY AT VERY COMPETITIVE PRICES. NO ONE OFFERS A BETTER ROOF, WALL OR FRAMING PACKAGE THAN US. THE TRUTH IS IN THE DETAILS - WE USE THE VERY SAME PANELS - PURLINS - GIRTS AND TRIM PACKAGE THAT THE MBMA MANUFACTURERS UTILIZE. THE ONLY DIFFERENCE IS THE STEEL TRUSS. THE STEEL TRUSS TAKES THE PLACE OF A RIGID FRAME.

COMPANY

CORPORATE AND SALES OFFICES ARE LOCATED IN VAN BUREN ARKANSAS. WITH OVER 15 MANUFACTURING PLANTS AND SHIPPING POINTS THROUGHOUT THE U.S., THE COMPANY ENJOYS A DISTINCT FREIGHT ADVANTAGE WITHIN THE INDUSTRY. ESTABLISHED IN 1982, SIMPSON STEEL HAS SHIPPED INTO ALL 50 STATES, CANADA AND CENTRAL AMERICA.

OUR PRODUCTS INCLUDE:

- RIGID FRAME (WIDE AND TALL SPAN COMMERCIAL/INDUSTRIAL)
- MINI STORAGE (SINGLE AND MULTI-STORY)
- NON STANDARD (SPECIALLY DESIGNED STRUCTURES)
- TRUSS FRAME (PATENTED STEEL TRUSS DESIGN, PROPRIETARY PRODUCT OF SIMPSON STEEL)

POINTS OF INTEREST:

- OVER 5,000 BUILDINGS COMPLETED NATIONWIDE (CHANCES ARE THERE IS A SIMPSON STEEL BUILDING WITHIN 50 MILES OF WHERE YOU LIVE)
- SHIPPED IN ALL 50 STATES AND CANADA
- ENGINEERING AVAILABLE FOR ALL 50 STATES
- UL 90 APPROVED SYSTEM
- QUICK TURN AROUND
 - DRAWINGS 10 DAYS TO 2 WEEKS (INDUSTRY STANDARD IS 3 TO 4 WEEKS)
 - ANCHOR BOLT PLAN CAN BE PROVIDED AS NEEDED (INDUSTRY STANDARD IS 2 WEEKS)
 - DELIVERY 2 TO 3 WEEKS AFTER RECEIPT OF SIGNED FABRICATION RELEASE (INDUSTRY STANDARD IS 8 TO 12 WEEKS)
 - DUNN AND BRADSTREET SUPERIOR RATING

ENGINEERING

STAMPED ENGINEERED DRAWINGS AND FOUNDATION DRAWINGS AVAILABLE FOR ALL 50 STATES. ALL DRAWINGS AND DESIGNS PERFORMED IN HOUSE BY OUR DESIGN TEAM.

FABRICATION

- ALL COMPONENTS ARE MADE IN THE U.S.A.
- SPECIALTY ITEMS (CLIPS, GUSSET PLATES, ETC.) ARE MANUFACTURED IN COLUMBUS, KANSAS AND SENT TO CUSTOMER VIA UPS.
- STRUCTURAL MEMBERS (ROOF, WALL PANELS AND TRIM) ARE MANUFACTURED IN THE SATTELITE PLANTS THROUGHOUT THE U.S.

SHIPPING

- INSULATION IS SHIPPED IN A COVERED VAN TO PROTECT THE PRODUCT FROM THE ENVIRONMENT
- CLIPS AND GUSSET PLATES ARE SHIPPED VIA UPS (GROUND SERVICE).
- IT IS THE RESPONSIBILITY OF THE CUSTOMER TO UNLOAD THE BUILDING UPON ARRIVAL
- FREIGHT IS PREPAID F.O.B. PLANT.

SHORTAGES AND BACKCHARGES

In order for **SIMPSON STEEL BUILDING COMPANY (SSBC)** to give you prompt service and keep problems to a minimum, please handle any shortages in the following manner:

Carefully check your packing list while unloading. Mark any items which appear to be missing and notify the Customer Service Department at 1-800-255-7624, as soon as possible by telephone. Calling someone else could delay the proper response.

I. SHORT MATERIALS

Immediately upon delivery of material, quantities are to be verified by the Customer against quantities that are billed on the shipping document. Neither the Manufacturer nor the carrier is responsible for material shortages against the quantities billed on shipping document. If such shortages are not noted on shipping documents when the material is delivered, and then acknowledged by the carrier's agent. If the carrier is the Manufacturer, claims for shortages are to be made by the Customer directly to the Manufacturer. If the carrier is a common carrier, claims for shortages are to be made by the Customer to the common carrier. If the material quantities received are correct according to the quantities that are on the shipping documents but are less than the quantities ordered or the quantities that are necessary to complete the metal building according to the Order Documents, claim is to be made of the Manufacturer. No later than seven (7) days after delivery.

II. DAMAGED OR DEFECTIVE MATERIAL

Damaged or defective material, regardless of the degree of damage, must be noted on the shipping documents by the Customer and acknowledged in writing by the carrier's agent. The Manufacturer is not responsible for material damaged in unloading or for packaged or nested materials, including, but not limited to, fasteners, sheet metal, "C" and "Z" sections and covering panels that become wet and/or damaged by water while in the possession of others. Package or nested materials that become wet in transit must be unpacked, unstacked and dried by the Customer.

If the carrier is the Manufacturer, claim for damage must be made by the Customer directly to the Manufacturer. If the carrier is a common carrier, the claim for damage must be made by the Customer to the common carrier. The Manufacturer is not liable for any claim whatsoever including, but not limited to, labor charges or consequential damages resulting from the Customer's use of damaged or defective materials that can be detected by visual inspection.

III. EXCESSIVE MATERIAL

The Manufacturer reserves the right to recover any materials delivered in excess of those required by the Order Documents.

IV. INITIAL CLAIM

INITIAL CLAIMS - In the event of error, the Customer must promptly make a written or verbal "Initial Claim" to the Manufacturer for the correction of design, drafting, Bill of Materials or fabrication error. The "Initial Claim" includes:

1. Description of the nature and extent of the errors, including quantities.
2. Description of the nature and extent of proposed corrective work, including estimated man-hours.
3. Material to be purchased from other than the Manufacturer, including estimated quantities and cost.
4. Maximum total cost of proposed corrective work and material to be purchased from other than the Manufacturer

SHORTAGES AND BACKCHARGES (CONT.)

AUTHORIZATION FOR CORRECTIVE WORK - If the error is the fault of the Manufacturer, an "Authorization for Corrective Work" must be issued in writing by the Manufacturer to authorize the corrective work at a cost not to exceed the maximum total cost set forth.

Alternative corrective work other than that proposed in the "Initial Claim" may be directed by the Manufacturer in the "Authorization for Corrective Work". Only the Customer Service Department may authorize corrective work.

V. FINAL CLAIM

FINAL CLAIM - The "Final Claim" in writing must be forwarded by the Customer to the Manufacturer within ten (10) days of completion of the corrective work authorized by the Manufacturer. The "Final Claim" must include:

1. Actual number of man-hours by date of direct labor use on corrective work and actual hourly pay rates.
2. Taxes and insurance on total actual direct labor.
3. Other direct costs on actual direct labor.
4. Cost of material (not minor supplies) authorized by the Manufacturer to be purchased from other than the Manufacturer to be purchased from other than the Manufacturer, including copies of paid invoices.
5. Total actual direct cost of corrective work (sum of 1,2,3 & 4). The "Final Claim" must be signed and certified true and correct by the Customer. "Final Claims" are credited to the Customer by the Manufacturer in an amount not to exceed the lesser of the maximum total cost set forth in writing in the "Authorization for Corrective Work" or total actual direct cost of corrective work.
6. Cost of equipment (rental or depreciation), small tools, supervision, overheads and profit are not subject to claims.

VI. STRUCTURAL FRAMING SHOP PRIMER

The coat of shop primer is intended to protect the steel framing for only a short period of exposure to ordinary atmospheric conditions. The coat of shop primer does not provide the uniformity of appearance, or the durability and corrosion resistance of a field applied finish coat of paint over a shop primer. The Manufacturer is not responsible for deterioration of the shop coat of primer or corrosion that may result from exposure to atmospheric and environmental conditions, nor the compatibility of the primer to any field applied coating. Minor abrasions to the top coat caused by handling, loading, shipping, unloading and erection after painting are unavoidable. Touchup of these minor abrasions is the responsibility of the Customer.

A strippable film has been added to preserve the color-finish during manufacturing and shipment. This film **MUST BE COMPLETELY REMOVED PRIOR TO INSTALLATION OF PRODUCT. If product is not immediately installed, the strippable film must be removed within 7 days if exposed to sunlight or 30 days otherwise.** Failure to do so may result in deterioration of the color-finish, nullifying the warranty. Remove by lifting film about 1" around entire piece, and then grab both sides and pull straight back over itself completely down the length. If film is formed into the hem of a piece, score it at the hem with a utility knife the entire length before lifting and removing the film.

VII. SHIPMENT ARRIVAL TIME

Every effort will be made to see that the carrier arrives at the jobsite on the requested day and at the requested hour. Manufacturer makes no warranty and accepts no responsibility for costs associated with a shipment not arriving at a requested time.

In most cases a delivery will be scheduled for a.m. or p.m. An a.m. delivery would be expected to be on site between 8:00 and 10:00 a.m. A p.m. delivery would be expected to be on site between 12:00 and 2:00 p.m. We will put you in direct contact with shipping to schedule your delivery.

INTRODUCTION AND PREFACE

We manufacture high quality, pre-engineered metal building packages. Quality erection is essential to complete the structure to the satisfaction of the customer.

This manual has been prepared to help guide the erection process and reflects the techniques in use in the metal building industry believed to be most representative of good erection practices. These procedures and methods are by necessity general in nature. The erector should always, especially in special circumstances, use proven and safe erection methods.

This erection manual is intended only as a supplement to the erection drawings that are furnished with each building. The erection drawings show the customer's building as engineered and fabricated according to his requirements. The building erection drawing will always govern with regard to construction details and specific building parts. Contact your customer service representative to resolve any matters not addressed.

The information contained in this manual is believed to be reliable, however, we disclaim any responsibility for damages which may result from use of this manual since the actual erection operations and conditions are beyond our control.

It is emphasized that we are only a manufacturer of metal buildings and components and not engaged in the erection of its products. Opinions expressed by us about erection practices are intended to present only a guide as to how the components could be assembled to create a building.

The MBMA's "CODE OF STANDARD PRACTICE" shall govern with respect to the fabrication tolerances, erection methods and all field work associated with the project in question.

The erector should familiarize him or her/self with the contents of this document.

PREFACE

This manual is to be used as a guide only. Details in this manual are generic and will reflect your building in some ways, all pictures are also generic to steel buildings. Always follow your individual framing plans (stamped "for construction"), for exact bay spacing, girt locations and framed opening locations.

SAFETY FIRST INFORMATION

READ AND UNDERSTAND THIS PAGE BEFORE PROCEEDING WITH ANY WORK OR FURTHER READING.

We have a commitment to manufacture quality building components that are designed to meet the structural requirements of the building. However, the safety commitment and job site practices of the erector are beyond our control and include expertise not possessed by the manufacturers.

It is urgently recommended that safe working conditions and accident prevention practices be the top priority on the job site, and that local, state and federal safety and health standards always be followed to help insure worker safety. These points cannot be stressed too strongly.

Job site safety is a joint responsibility of all parties present on the job site, including owners, architects, engineers, contractors, subcontractors, delivery personnel and employees of all the above, among others. All should be watchful to avoid hazards which might cause damage to property or injury to any person including themselves.

Always make certain all employees know the safest and most productive way of erecting a building along with emergency telephone numbers, location of first aid stations and emergency procedures. Avoid working during inclement weather periods when personnel are at increased risk due to high winds, lightning, precipitation, etc.

We recommend daily meetings highlighting safety procedures, the use of hard hats, rubber sole shoes for roof work, proper equipment for handling material and appropriate safety gear, including nets where necessary.

This manual should be interpreted and administered with sound judgement consistent with good safety practices. Its' information is to be distributed to all workers on the job site. Where any doubt exists as to the language or direction of this manual, do not take a risk, "play it safe".

HARDWARE DETAILS

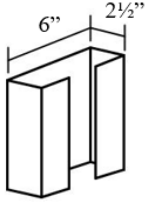

BOTTOM CORD,
CENTER KINGPIN,
S-1,S-2,S-3

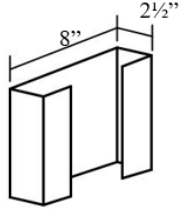

GIRTS, JAMBS,
HEADERS

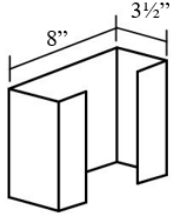

STANDARD
COLUMN

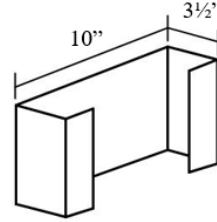

STANDARD
RAFTER

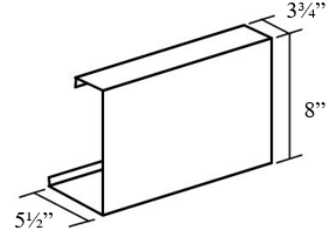

EAVE STRUT

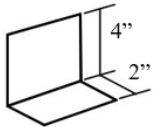

GABLE / BASE ANGLE,
FLANGE BRACE
(20'-0" LENGTHS)

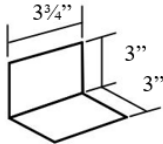

UP-4 CLIP
(PURLIN CLIP)

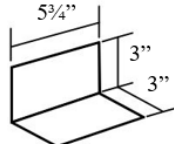

UP-6 CLIP
(FLANGE BRACE, PURLIN
CLIP WHEN TRUSSES ARE

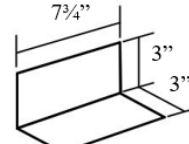

UP-8 CLIP
(GIRT, HEADER
AND JAMBS)

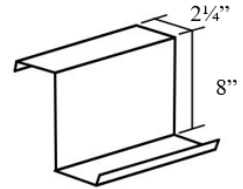

PURLIN
(ONLY 'Z' ON JOB)

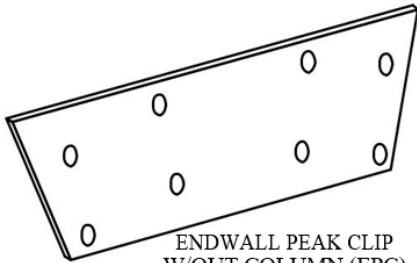

ENDWALL PEAK CLIP
W/OUT COLUMN (EPC)

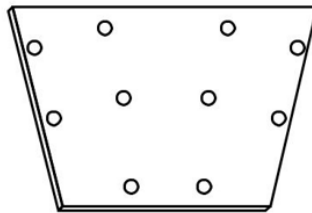

GUSSET PLATE 2
(GP-2)

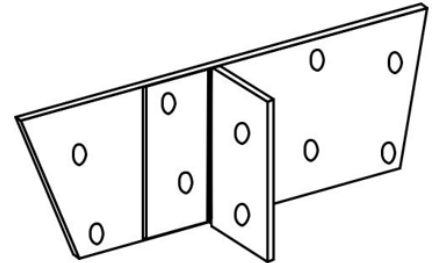

ENDWALL PEAK CLIP
WITH COLUMN (EPC)

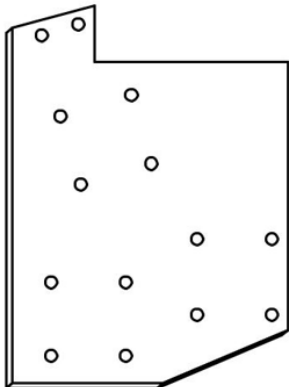

GUSSET PLATE 1
(GP-1)

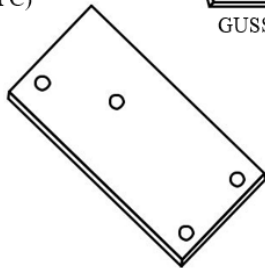

GUSSET PLATE 4
(GP-4)

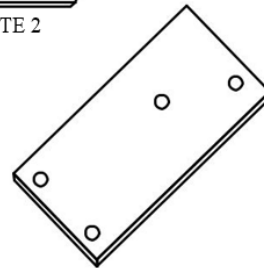

GUSSET PLATE 4
(GP-4)

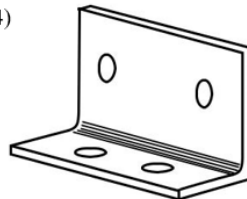

BASE CLIP (BC-6)
3" x 3" x 3/16"

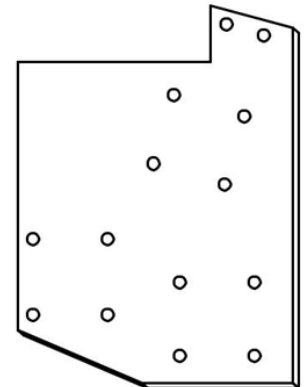

GUSSET PLATE 1
(GP-1)

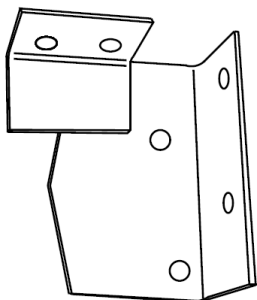

CORNER COLUMN
CLIP LEFT (CCCL)

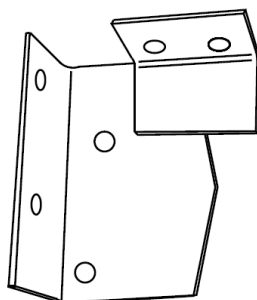

CORNER COLUMN
CLIP RIGHT (CCCR)

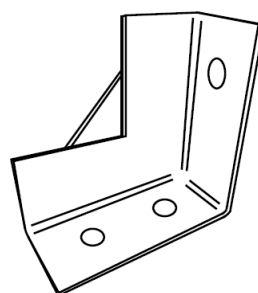

CABLE BRACE
CORNER CLIP (CBC)

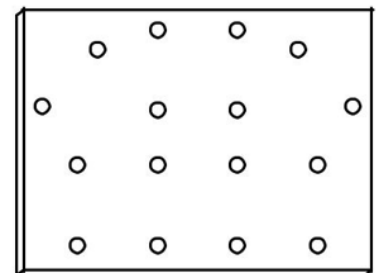

GUSSET PLATE 3
(GP-3)

HARDWARE DETAILS



LTC-1
3:12 CLIP

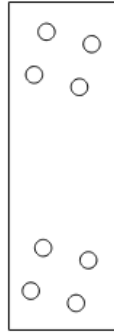

LTC-2
1:12 CLIP

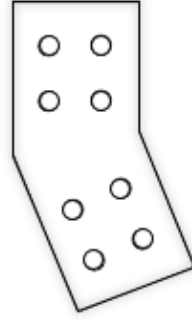

LTC-3 3:12
& 1:12 CLIP



LTC-4 3:12
& 1:12 CLIP

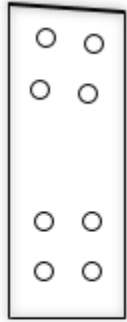

SP1
1:12 CLIP

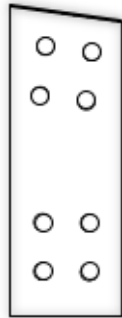

SP2
2:12 CLIP



SP3
3:12 CLIP



WPC
3:12 CLIP

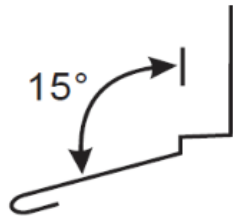

PARAPET HIGH
3:12 EAVE TRIM [D]

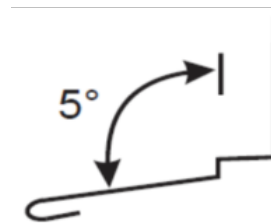

PARAPET HIGH
1:12 EAVE TRIM [C]

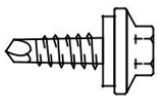

NO. 14 x 7/8" LAP TEK
SHORT FAT SCREW - LAP

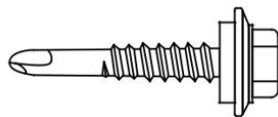

NO. 12 x 1 1/4" TEK
PANEL TO STRUCTURE



IMPAX 4.5 NO WASHER
STRUCTURAL

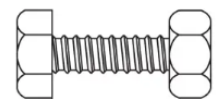

1/2" x 1 1/4" A325 BOLT
WASHER. NUT ASSEMBLY

HARDWARE DETAILS



MASTIC TAPE



POP RIVET



OUTSIDE
FOAM CLOSURE



DOWNSPOUT ELBOW

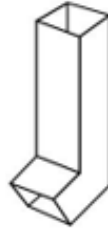

DOWNSPOUT



INSIDE
FOAM CLOSURE

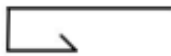

JAMB TRIM



HEAD TRIM



SPECIAL HEAD
@ OVERHANG

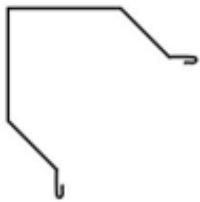

CORNER TRIM



INSIDE CORNER TRIM



BASE TRIM



HANG-ON GUTTER



GUTTER END



GUTTER STRAP



DOWNSPOUT STRAP



EAVE TRIM



RAKE TRIM



WAINSCOT
20'-0 LENGTHS



SOFFIT CAP

SECTION 1

BASIC CHECKLIST FOR BUILDING ERECTION W/OUT OVERHANG

RED IRON SECTION

- 1) INVENTORY MATERIAL; RED IRON, SHEETS, TRIM ETC.
- 2) LOCATE COLUMNS
- 3) BOLT BC-6 CLIPS TO BASE OF COLUMNS
IMPORTANT: PROVIDE TEMPORARY BRACING AS NEEDED TO SUFFICIENTLY BRACE THE STRUCTURE AS ERECTION PROCEEDS.
- 4) SCREW UP-8 CLIPS TO COLUMNS AT LOCATIONS SPECIFIED BY FRAMING PLANS
- 5) BOLT CCCR AND CCCL CLIPS TO COLUMNS
- 6) BOLT PEAK CLIP TO CENTER COLUMN AT ENDWALLS (IF CENTER COLUMN IS REQUIRED)
- 7) LOCATE RAFTERS
- 8) SCREW UP-4 CLIPS TO RAFTERS AT LOCATIONS SPECIFIED BY FRAMING PLANS
- 9) LOCATE JAMB AND HEADERS
- 10) SCREW UP-8 CLIPS TO HEADERS, JAMBS AND COLUMNS AS SHOWN ON FRAMING PLANS
- 11) BOLT BC-6 CLIPS TO BASE OF OVERHEAD DOOR JAMBS (IF REQUIRED)
- 12) LOCATE GIRTS
- 13) PLACE GIRTS AROUND PERIMETER OF BUILDING AT FRAMING PLAN LOCATIONS ON GROUND
- 14) LOCATE TRUSS MATERIAL
- 15) PRE-ASSEMBLE TRUSS ON GROUND (RECOMMENDED METHOD) SEE FRAMING PLAN FOR TRUSS DETAIL
- 16) STAND ALL COLUMNS AND OVERHEAD DOOR JAMBS ACCORDING TO ANCHOR BOLT LOCATIONS
- 17) SET GIRTS AT CLIP LOCATIONS
- 18) SCREW GIRTS ONTO CLIPS
- 19) ATTACH ENDWALL RAFTERS TO CORNER COLUMN CLIPS AND ENDWALL PEAK CLIP, ONE END OF BUILDING ONLY
- 20) HANG TRUSS AND ATTACH TO C-2 COLUMNS
- 21) PLACE PEAK PURLINS, ONE FOOT OFF OF CENTER ON BOTH SIDES FROM TRUSS TO ENDWALL *IF YOUR BUILDING HAS AN OVERHANG REFER TO FOLLOWING PAGE FOR INSTRUCTIONS*
- 22) ATTACH EAVE STRUTS ONTO FIRST BAY
NOTE: IF BUILDING HAS MORE THAN TWO BAYS, REPEAT STEP 20 AND PLACE PEAK PURLINS ONE FOOT OFF CENTER BOTH SIDES FROM TRUSS TO TRUSS. THEN ATTACH EAVE STRUTS
- 23) ATTACH OPPOSITE ENDWALL RAFTERS
- 24) HANG PEAK PURLINS FROM TRUSS TO ENDWALL
- 25) ATTACH REMAINING EAVE STRUTS
- 26) ATTACH REMAINING PURLINS
- 27) LOCATE WALKDOOR AND WINDOW FRAMED OPENINGS, IN REQUIRED
- 28) ATTACH GABLE ANGLE
- 29) ATTACH BASE ANGLE
- 30) INSTALL FLANGE BRACES AT PURLIN TO RAFTER CONNECTIONS ACCORDING TO FRAMING PLANS

SHEET AND TRIM SECTION

- 31) INSTALL JAMB AND HEAD TRIM FOR WINDOWS AND WALKDOORS IF REQUIRED
- 32) PREDRILL WALL SHEETS
- 33) HANG INSULATION PER MANUAL (IF PURCHASED), BASE TRIM AND WALL SHEETS, IN THAT ORDER
- 34) INSTALL CORNER TRIM
- 35) INSTALL EAVE TRIM
- 36) HANG INSULATION PER MANUAL (IF PURCHASED), ROOF SHEETS AND RIDGE CAP, IN THAT ORDER
- 37) INSTALL RAKE TRIM
- 38) INSTALL PEAK BOX
- 39) HANG GUTTER (IF PURCHASED)
- 40) HANG CORNER BOXES (IF PURCHASED GUTTER)
- 41) INSTALL OVERHEAD DOORS BY OTHERS IF REQUIRED

SECTION 1

BASIC CHECKLIST FOR BUILDING ERECTION WITH OVERHANG

RED IRON SECTION (SEE DETAIL BELOW)

- 1) INSTALL PEAK PURLINS
- 2) FIELD DRILL HOLES IN OC-3 CHANNEL FOR B-2 RAFTER
- 3) BOLT EAVE STRUTS TO RAFTERS, ON TRUSS FIT INSIDE OF OC-3 CHANNEL
- 4) ASSEMBLE REMAINING PURLINS
- 5) SCREW OC-1 TO EAVE STRUT AND FIRST PURLIN ON EACH END OF BUILDING
- 6) INSTALL OC-2, FROM INSIDE OC-1 TO INSIDE OC-3. IF MORE THAN 2-BAYS, ALSO ATTACH FROM OC-3 TO OC-3
- 7) ATTACH GABLE ANGLE ACCORDING TO FRAMING PLANS
- 8) CONTINUE WITH NORMAL ASSEMBLY OF BUILDING

TRIM SECTION

- 1) INSTALL INSULATION (IF REQUIRED) AND WALL SHEETS ACCORDING TO MANUAL
- 2) INSTALL HEAD TRIM FOR SOFFIT AT BUILDING
- 3) INSTALL SOFFIT PANEL (REVERSE RUN 'R' PANEL)
- 4) INSTALL SOFFIT CAP
- 5) INSTALL EAVE TRIM IF REQUIRED
- 6) CONTINUE WITH NORMAL ASSEMBLY OF TRIM

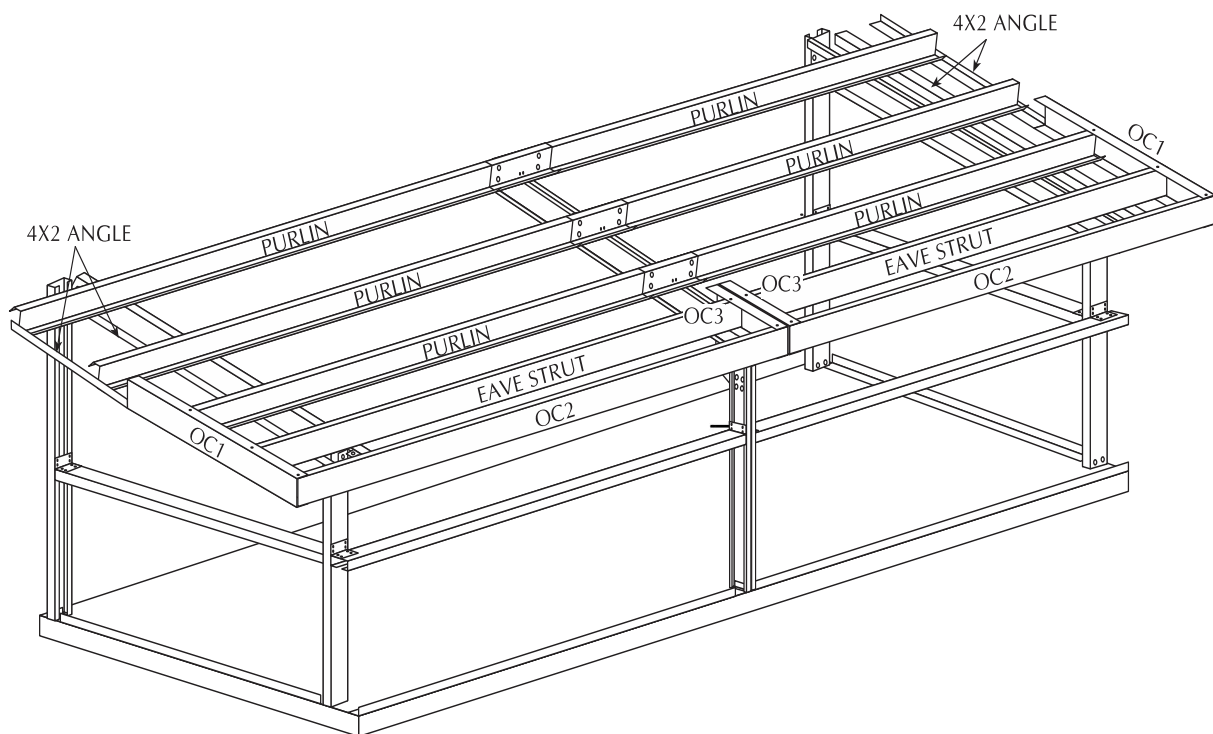

SAMPLE BUILDING
WITH OVERHANG DETAIL

BUILDING COMPONENT DEFINITIONS

18" RAKE OVERHANG

18" overhang off of gable end of building. This is an extension of the eve strut and purlin, complete with soffit for end of building.

18" EAVE OVERHANG

18" overhang off of side of building. This is a separate framing system that attaches to the top chord of the truss to create the overhang. Complete with soffit for one side of building.

LINER PANEL

29 ga. white liner panel, on inside of building. Complete with base girt instead of base angle, includes fasteners and trim.

ANCHOR BOLTS

Foundation Engineer will specify the size and type of anchors to use (Anchor bolts are part of the concrete and thus are not included). Usually 5/8" x 18" bolts used to anchor structure to the concrete. It is recommended to use welded plate (or J bolt) and place in the concrete as it is poured using a template. They can also be drilled in and expansion anchors used.

ANCHOR BOLT PLAN

A detailed bolt setting plan furnished by SSBC with every building. It tells the exact location and size of bolts to be used for each building.

BASE ANGLE

A 4" x 2" angle secured to the floor or foundation used to secure the bottom of the wall panels. Attach to slab with concrete fasteners or expansion anchors 36" inches on center, max.

BASE CLIP

An angle clip (BC-6) attached to the bottom of a column or overhead door jamb and then anchored to the concrete using the anchor bolts.

BASE GIRT

This is to be used when a building is to be placed on piers or when using a liner panel, instead of a perimeter foundation. or slab. It substitutes a base girt in place of base angle.

BASE TRIM

Used to seal off the bottom of the wall panel. This trim goes behind the wall panel, extends under the panel, attaches to the base angle or base girt and seals off the bottom of the sheet.

BAY

The space between the trusses measured normally from column to column. (Example; a 60' foot building would have (3) 20' foot bays).

'C' SECTION

A cold formed member rolled from a sheet of steel in the shape of a 'C'. In the steel truss design, the columns, rafters, Jams, and headers are normally a 'C' shape.

CLIP

A plate or angle used to fasten two or more framing members together.

COLUMN

A main member used in a vertical position on a building to transfer loads from beams, trusses, or rafters to the foundation.

CORNER COLUMN CLIP

A red-iron angle used in both the main building and lean-to left and right endwall corners to connect three structural members. These are also known as Corner Column Clip Left (CCCL) and Corner Column Clip Right (CCCR). Connects the outside end of the B-1 or B-3 rafters, the top of the C-1 or C-4 column, and end of the ES1 eave strut. There are six total pre-drilled holes in the clip, two on each angle. The clip is attached to the flush side of each member and uses six total A325 bolts, nuts and washer assemblies.

SECTION 1

BUILDING COMPONENT DEFINITIONS CONTINUED

DOWNSPOUT

The conduit used to carry water from the gutter of a building to the ground.

EAVE

The line along the top of the sidewall formed by the intersection of the roof and wall sheets.

EAVE HEIGHT

The vertical dimension from finish floor to the top of the eave strut.

EAVE STRUT

A structural member, usually 'C' shape, that is bolted on top of the B-1 and B-2 rafters on the outer edges of the building.

ENDWALL

See "GABLE".

ERECTION DRAWINGS

The framing plans supplied by SSBC.

FLANGE BRACE

A member used to provide lateral support to the flange of a structural member.

FRAMED OPENING

Framing members which surround an opening.

GABLE

The triangular portion of the end wall from the level of the eave to the ridge of the roof.

GIRT

A horizontal structural member that is attached to sidewall or end wall columns and supports sheeting.

HEADER

The horizontal framing member that is located at the top of a framed opening.

JAMB

The vertical framing members located at the sides of an opening.

LEAN-TO

A structure having only one slope and depending upon another structure for partial support.

LTC-1 LEAN-TO CLIP

A flat red-iron plate fabricated specifically for a 3:12 pitch continuous lean-to. Connects the main building's B-1 or B-2 rafters to the continuous lean-to's B-3 or B-4 rafters. There are eight total pre-drilled holes in the clip, four on each end. The clip is attached using eight total A325 bolts, nuts, and washer assemblies. For interior rafters, the clip is "sandwiched" between the back-to-back main building rafters and lean-to rafters. On the end walls, the clip will be inside the web of the main building rafter and lean-to rafter to keep the LTC-1 clip opposite the corner column clips.

LTC-2 LEAN-TO CLIP

A flat red-iron plate fabricated specifically for a 1:12 pitch off eave lean-to. Connects the main building's B-1 or B-2 rafters to the off eave lean-to's B-3 or B-4 rafters. There are eight total pre-drilled holes in the clip, four on each end. The clip is attached to each rafter using eight total A325 bolts, nuts, and washer assemblies. For interior rafters, the clip is "sandwiched" between the back-to-back main building rafters and lean-to rafters. On the end walls, the clip will be inside the web of the main building rafter and lean-to rafter to keep the LTC-2 clip opposite the corner column clips.

LTC-3 LEAN-TO CLIP

A flat red-iron plate fabricated specifically for a 3:12 or 1:12 pitch under eave lean-to. Connects the main building's sidewall C-2 truss columns to the under eave lean-to's interior B-4 rafters. There are eight total pre-drilled bolt holes in the clip, four on each end. Each end of the clip is "sandwiched" between the back-to-back main building columns and lean-to rafters. These clips use eight total A325 bolts, nuts, and washer assemblies. Please note that the holes in the columns should be drilled in the field, per locations given in the plans.

BUILDING COMPONENT DEFINITIONS CONTINUED

LTC-4 LEAN-TO CLIP

A flat red-iron plate fabricated specifically for a 3:12 or 1:12 pitch under eave lean-to. Connects the main building's endwall C-1 corner columns to the under eave lean-to's exterior B-3 rafters. There are six total pre-drilled bolt holes in the clip, two on the column end and four on the rafter end. The clip will be inside the web of the lean-to rafter and the flush side of the main-building C-1 column. These clips use six total A325 bolts, nuts, and washer assemblies. Please note that the holes in the columns should be drilled in the field, per locations given in the plans.

MASTIC

$\frac{3}{8}$ " x $\frac{3}{32}$ " tape sealant used to seal side laps on roof sheets and ridge caps. Comes in 45' foot rolls.

PANELS

Typically, 26ga. 80,000 psi for roof and walls

PARAPET HIGH EAVE TRIM

Used in an under eave lean-to. The parapet eave trim is provided at the transition from wall panels to lean-to roof panels in order to prevent water from entering the building.

PEAK SIGN

A sign attached to the peak of the building showing the building manufacturer.

PIER

A concrete structure designed to transfer vertical load from the base of a column to the footing.

PITCH

The peak height of a gabled building divided by its overall span.

PURLIN

A horizontal structural member which supports roof covering.

RAFTER

The main beam supporting the roof system.

RAKE

The intersection of the plane of the roof and the plane of the end wall.

RAKE ANGLE

Angle fastened to purlins at rake for attachment of end wall panels.

RAKE TRIM

A flashing designed to close the opening between the roof and end wall panels.

RIB

The longitudinal raised profile of a panel that provides much of the panel's bending strength.

RIDGE

The horizontal line formed by opposing sloping sides of a roof running parallel with the building length.

RIDGE CAP

A transition of the roofing materials along the ridge of a roof; sometimes called ridge roll or ridge flashing.

ROOF SNOW LOAD

The load induced by the weight of snow on the roof of the structure. Usually obtained by taking a fraction of the "ground snow load".

SELF-DRILLING SCREW

A fastener which combines the functions of drilling and tapping.

SIDEWALL

An exterior wall which is perpendicular to the frames of a building system.

SOFFIT

A material which covers the underside of an overhang.

BUILDING COMPONENT DEFINITIONS CONTINUED

SP1 LEAN-TO CLIP

A flat red-iron plate fabricated for any 1:12 pitch style lean-to. Connects the top of lean-to's interior sidewall C-5 columns to the end of the lean-to's B-4 rafter. There are eight total pre-drilled bolt holes in the clip, four on each end. Each end of the clip is "sandwiched" between the back-to-back columns and rafters of the lean-to. These clips use eight total A325 bolts, nuts, and washer assemblies.

SP2 LEAN-TO CLIP

A flat red-iron plate fabricated specifically for a 3:12 pitch wrap around porch. Where the sidewall lean-to and endwall lean-to merge to form the hip portion of the wrap around porch, this merger corner ends up being a 2:12 pitch unlike the rest of the lean-to at a 3:12 pitch. This specialty clip connects the top of lean-to's corner column to the end of the lean-to's corner rafter. There are eight total pre-drilled bolt holes in the clip, four on each end. Each end of the clip is "sandwiched" between the back-to-back columns and rafters of the wrap around porch. These clips use eight total A325 bolts, nuts, and washer assemblies. See "Wrap Around Porch at 3:12 Pitch" subsection.

SP3 LEAN-TO CLIP

A flat red-iron plate fabricated for any 3:12 pitch style lean-to. Connects the top of lean-to's interior sidewall C-5 columns to the end of the lean-to's B-4 rafter. There are eight total pre-drilled bolt holes in the clip, four on each end. Each end of the clip is "sandwiched" between the back-to-back columns and rafters of the lean-to. These clips use eight total A325 bolts, nuts, and washer assemblies.

STEEL TRUSS

A structure made up of seven members, with each member designed to carry a tension or compression force. Simpson Steel Building Company has a patent on the steel truss design we use.

TRANSLUCENT PANELS

Panels used to admit light.

TRIM

The light gage metal used in the finish of a building, especially around openings and at intersections of surfaces. Often referred to as flashing.

WAINSCOT

Wall material, used in the lower portion of a wall, that is usually a different color from the material used in the rest of the wall.

WIND LOAD

The load caused by wind force from any horizontal direction.

WPC CLIP

A flat red-iron plate fabricated specifically for a 3:12 pitch wrap around porch. Where the sidewall lean-to and endwall lean-to merge to form the hip portion of the wrap around porch, this merged corner ends up being a 2:12 pitch unlike the rest of the lean-to at a 3:12 pitch. This specialty clip connects the main building's endwall C-1 corner column to the top of the lean-to's corner rafter. There are four total pre-drilled bolt holes at the end of the clip. The rafter end of the clip is "sandwiched" between the back-to-back wrap around porch rafters. This end of the clip uses eight total A325 bolts, nuts, and washer assemblies. The column end of the clip is attached by welding to the LTC-4 clip. The exact angle is unknown and must be calculated by the erector in the field. See "Wrap Around Porch at 3:12 Pitch" subsections.

Z PURLIN

A member cold formed from steel in the shape of a 'Z'.

SECTION 1

FOUNDATION & BUILDING ANCHORAGE

GENERAL FOUNDATION INFORMATION

Before performing any excavation, we recommend that you call 1-800-DIGSAFE to assure that you do not dig through any buried utilities, phone lines, etc.

SSBC recommends that all building foundations, including pier sizes, grade beams and floor slabs, be designed by an experienced local foundation engineer. This engineer can also recommend excavation procedures, drainage practices, form work, reinforcing steel requirements and concrete proportioning. This will assure proper designs, expedite the work and reduce costs.

Proven construction techniques should be adhered to in the foundation work. The bottoms of all excavations should be level and smooth, and care should be taken to prevent cave-ins when utilizing the walls of the excavations for concrete forms. Strict adherence to OSHA and other local codes or laws governing “shoring of excavation to prevent accidental cave-ins” is critical. Where the ground surface is not level, the bottoms of the foundations should be in steps coinciding with the piers (as shown). Fill areas should be properly compacted to prevent settling cracks. Footing should extend below any fill material.

Care should be taken to obtain a good finish on the floor slab and to maintain the correct elevation throughout the slab. Shrinkage cracks can be minimized by pouring the slab in alternate sections, “checkerboard fashion”. The outer corners of the foundation walls and piers should be sharply formed with straight sides and level tops. This will allow neat seating and good alignment of the base angle.

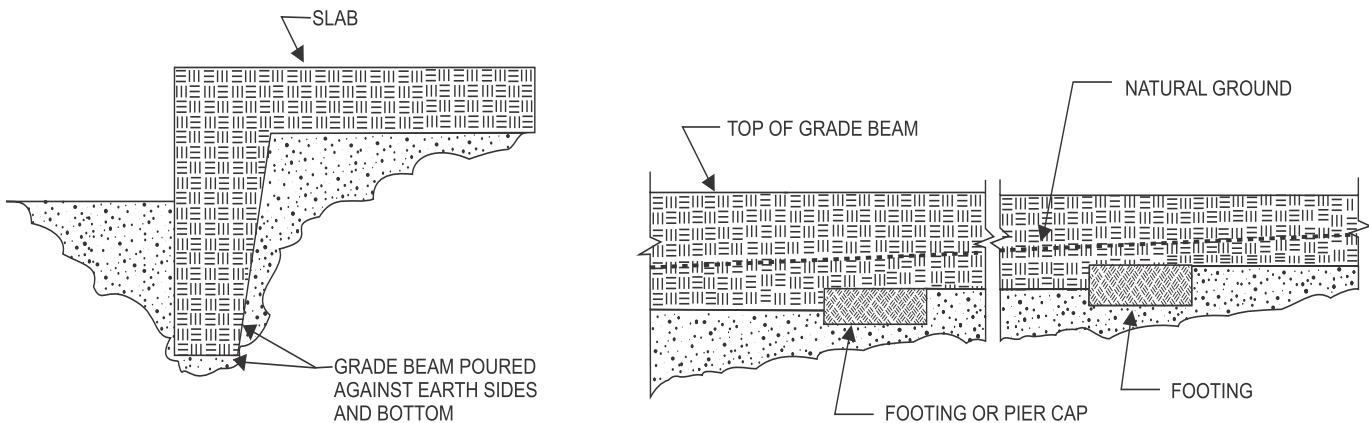

FOUNDATION CHECKING PROCEDURES

The importance of accurate foundation construction and anchor bolts settings cannot be overemphasized. Foundation errors and mis-location of anchor bolts are among the most frequent and troublesome errors made in metal building construction. The following procedures and methods should help to minimize these costly errors and delays.

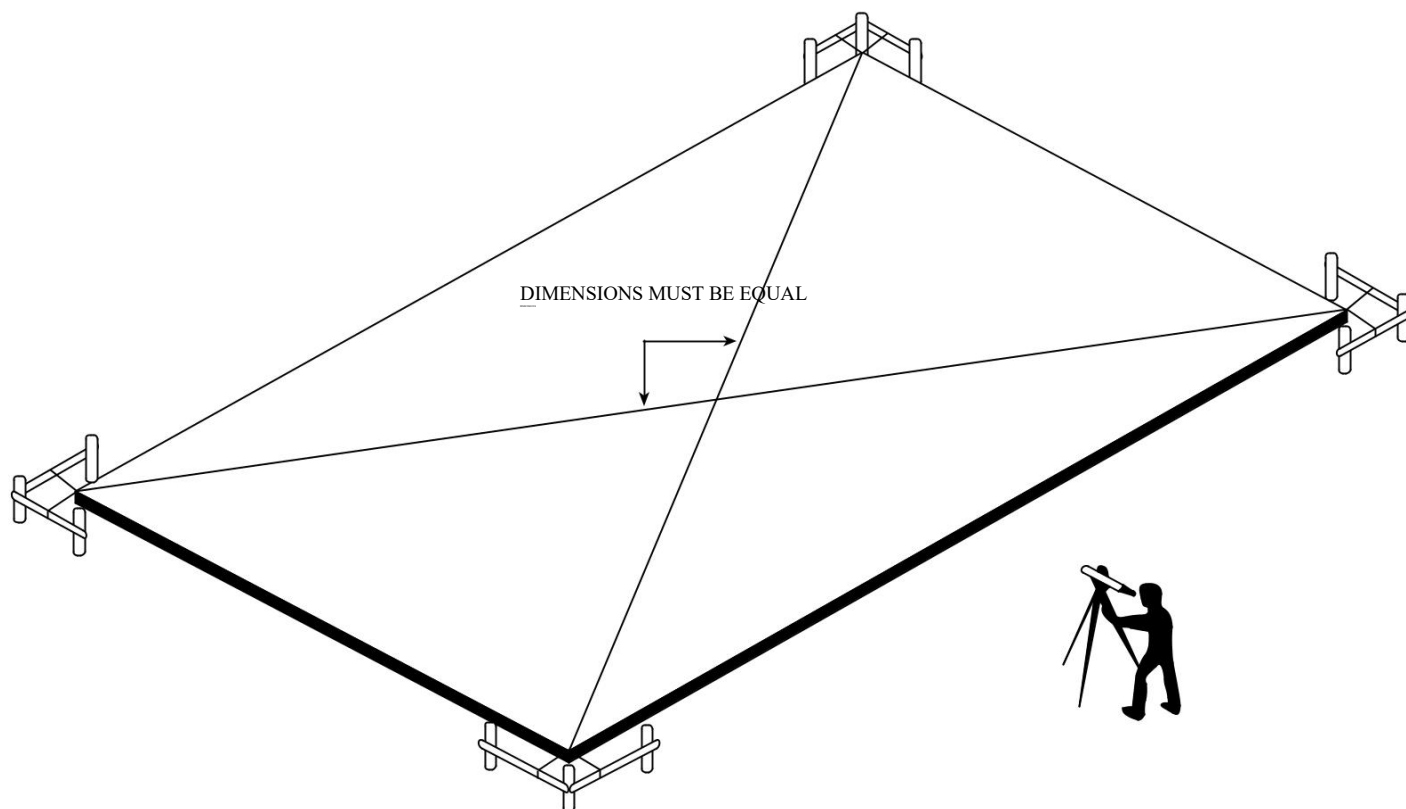

1. To determine that the foundation is square, measure diagonal dimensions to be sure they are of equal length.
2. To determine that the foundation is level, set up a transit or level and use a level rod to obtain the elevation at all columns and posts.
3. Carefully check the location of all anchor bolts against the “Anchor Bolt” drawing furnished by **SSBC**. All dimensions must be identical to assure a proper start-up.

SECTION 1

ANCHOR BOLT SETTINGS

It is extremely important that anchor bolts be placed accurately in accordance with the anchor bolt setting plan. All anchor bolts should be held in place with a template or similar means, so that they will remain plumb and in the correct location during placing of the concrete. Check the concrete forms and anchor bolt locations prior to the pouring of the concrete. **A final check should be made after the completion of the concrete work and prior to the steel erection.** This will allow any necessary corrections to be made before any costly erection labor and equipment arrives. **SSBC does not furnish anchor bolts. They can be purchased from any local hardware store in your area.**

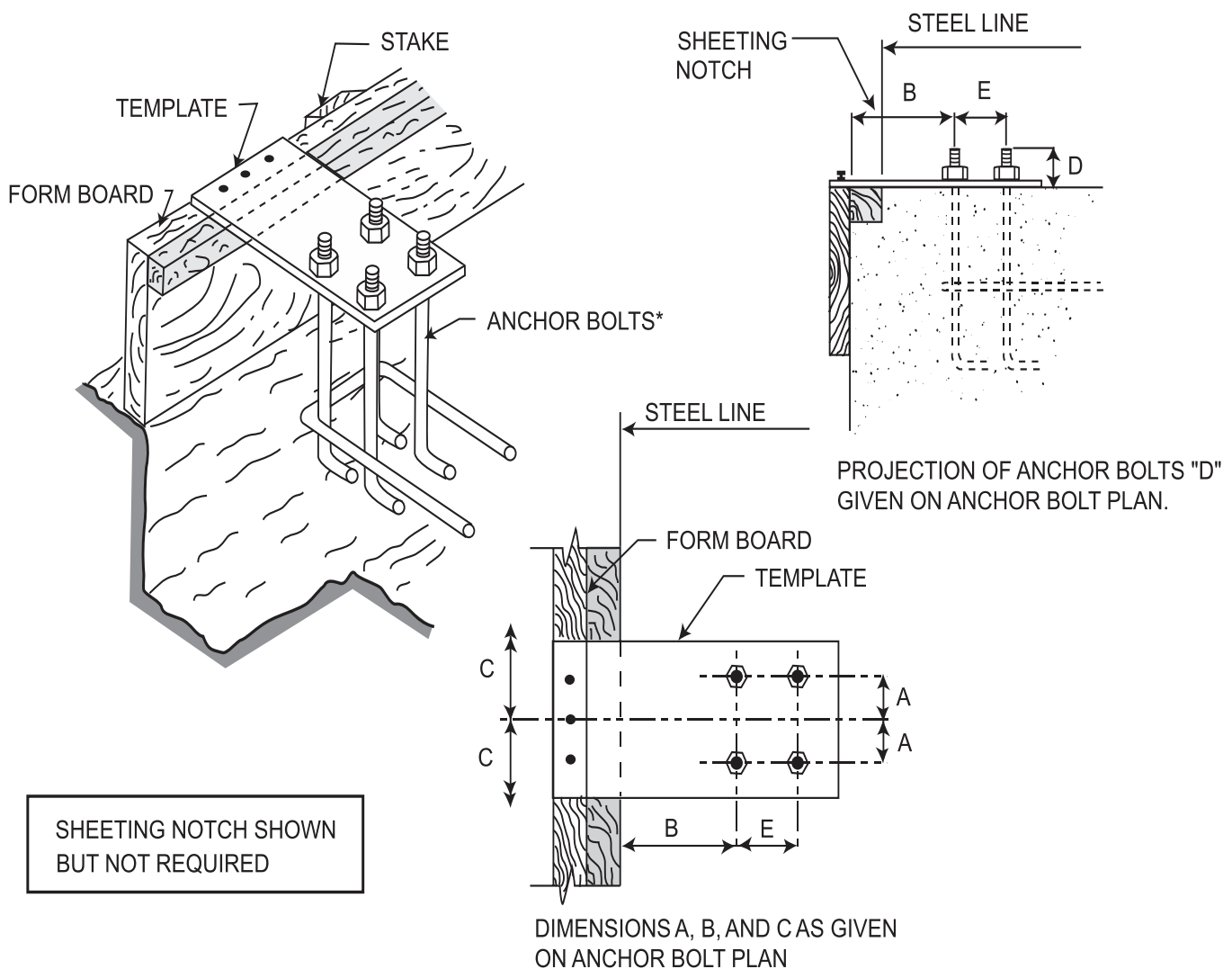

* Unless noted, anchor bolts are not by manufacturer.

Never place anchor bolts by hand, use template MADE TO SCALE to assure accuracy.

Note: Templates in back of manual are examples and are not to scale

SECTION 2

PRE-ERECTION OF BUILDING ACCESS TO THE SITE

The vehicle transporting your building parts must gain access to the building site from the adjacent highway or road. Such access should be studied and prepared in advance of arrival. All obstructions, overhead and otherwise, must be removed and the access route graveled or planked if the soil will not sustain the heavy wheel loads. In most cases the truck will be an 18-wheeler with a 48' foot flatbed trailer.

Inspect to ensure that there is enough room to physically perform the tasks required to erect the building. Application of sheeting and trim can be expensive when there is not sufficient working space because of the proximity of adjacent buildings or other obstacles.

The availability of any required utilities should also be considered in advance. Take careful note of any overhead electric lines or other utilities to avoid hazards and damage (Notify your electric company(s) when necessary).

Develop a comprehensive safety awareness program in advance to familiarize the work force with the unique conditions of the site, and the building materials, along with the appropriate "Safe Work" practices that will be utilized.

Sample Map to Job Site

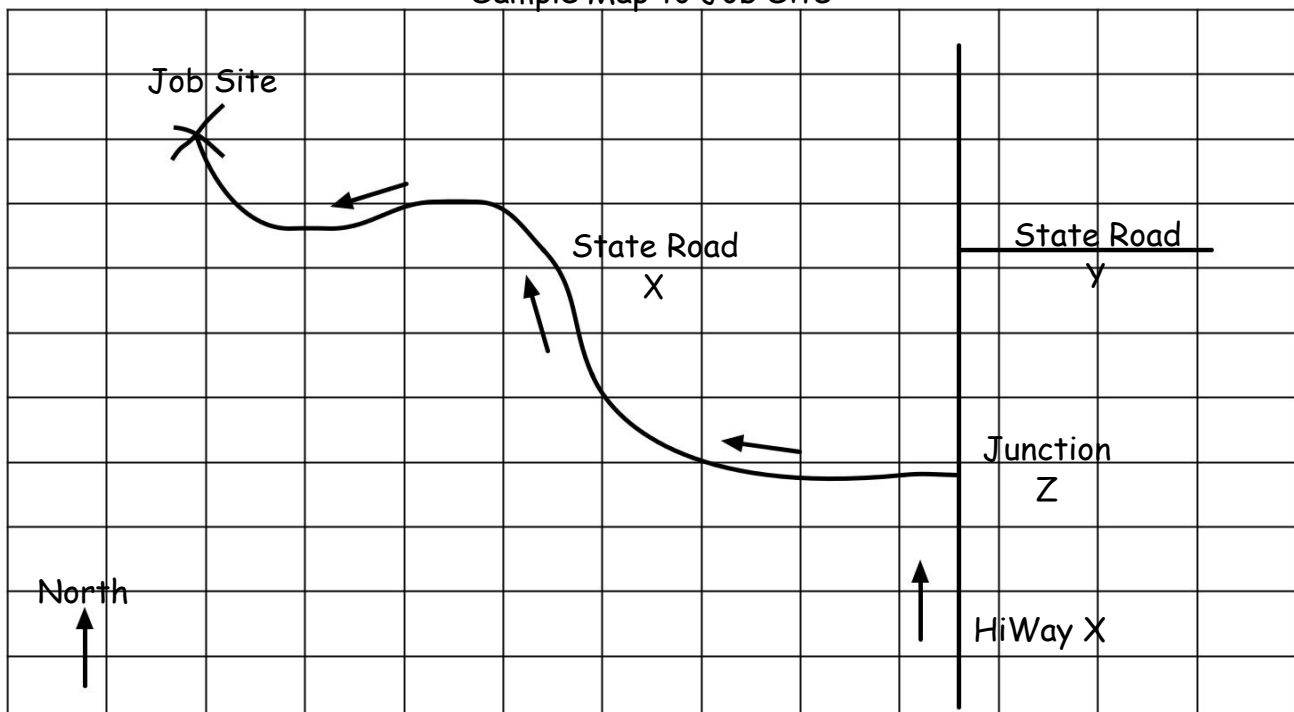

UNLOADING OPERATIONS

Pre-planning of the unloading operations is an important part of the erection procedure. This involves careful, safe and orderly storage of all materials. Detailed planning is required at the job site where storage space is restricted. Here, a planned separation of materials in the order of the erection process is necessary to minimize the costly double handling of materials. While set procedures are not possible in all cases, special attention should be given to the following items.

NOTE! Trucks are loaded to maximize efficiency, maximize trailer weight and ensure safety. Unfortunately, *SSBC* cannot load trucks per customer request.

*****THINK SAFETY AT ALL TIMES*****

1. Location of carrier vehicle during unloading

Unload material near their usage points to minimize lifting, travel, and rehandling during building assembly.

2. Prepare necessary ramp for truck

The edge of the concrete slab should be protected to minimize the danger of chipping or cracking from truck traffic if the materials are to be laid out on the slab. One important safety consideration is the fact that materials stored on the slab may subject workers from possible injury from falling objects.

3. Schedule lifting equipment (not by *SSBC*)

The type and size of lifting equipment is determined by the size of the building and the site conditions. Length of boom, capacity and maneuverability of lifting equipment will determine its location for both unloading and erection. The most common equipment used is an all-terrain forklift or tractor with loader and forks.

Use the same lifting equipment to unload and erect structural parts. Lifting equipment costs are usually minimized by combining the unloading process with building erection.

4. Consideration of overhead electric wires

Overhead power lines are a continuing source of danger. Extreme care must be used in locating and using lifting equipment to avoid contact with power lines.

5. Schedule crew

Depending on the crew size, valuable time can generally be gained if the supervisor plans and watches ahead instead of getting tied up with a particular unloading chore.

UNLOADING OPERATIONS CONTINUED

6. Check shipment!!!

When shipments are received in the field, two inspections are necessary:

a. If during the inspection, damages, or shortages of items are found, a report should be filed with the carrier immediately at the site. When damages are evident from the exterior at the time of receiving shipments. Panel crates should be opened and inspected for water damage. Galvanized or galvalume panel crates should always be opened and inspected for white or black rust.

b. When bundles crates, cartons, boxes, etc. are opened following delivery, another check must be performed to determine the quantity received and their condition. If during this inspection damages or shortages of items are found upon opening the crates or cartons, a claim should be sent to **SSBC**, **no later than seven (7) days after delivery.**

Unless these two important inspections are made and any reports or claims are filed immediately, settlements become very difficult and usually all parties suffer the loss.

NOTE! Even when **SSBC** trucks are in the delivery, careful attention should be paid to the material, and claims filed in the same timely manner.

When filing claims either with the carrier, or with Simpson Steel Buildings, the claim should indicate the item(s) in question, the bundle or container in question (if any), the actual quantity received, the quantity which should have been received, or that which was damaged. This is important for quickly retrieving the necessary information. Also, other information such as numbers, names and addresses of consignees and consignors should be indicated on claims, as well as invoice numbers. Pictures of the items in question should be provided with the claim.

These procedures are primarily for your protection. A shortage discovered later than 7 days, can be caused by theft, misplacement, or other causes, and neither the carrier nor **SSBC** can accept responsibility.

NOTE! Galvanized and galvalume materials are susceptible to damage from prolonged periods of contact with moisture while stacked together. If there is evidence of moisture during unloading, the panels should be separated, dried and stored out of the weather to prevent permanent discoloration. Never install any material if its' quality is in question.

(See Customer Service Procedures for further details)

LOCATION OF BUILDING PARTS

- Columns and truss components are usually unloaded near their respective installed position on the slab for easy makeup.
- Endwalls are usually laid out at each end of the slab with the columns near respective anchor bolts.

NOTE! An access area through the center of the building should be left for erection equipment.

- Hardware packages should be located centrally, usually along one sidewall near the center of the building. This will minimize walking distances to other parts of the slab area.
- Purlins and girts, depending on the number of bundles, are usually stored near the sidewalls clear of other packages or parts.
- Sheet packages are usually located along one or both sidewalls off the ground and sloping to one end to encourage drainage in case of rain.
- Accessories are usually unloaded on a corner of the slab or off of the slab near one end of the building to keep them as much out of the way as possible from the active area during steel erection.

NOTE! Steps must be taken to protect the entire job site from vandalism and pilferage.

UNLOADING, HANDLING AND STORING MATERIALS

STRUCTURAL MATERIAL

As previously emphasized, a great amount of time and trouble can be saved if the building parts are unloaded at the building site according to a pre-arranged plan. Proper location and handling of components will eliminate unnecessary handling.

Inspect all shipments prior to releasing the tie-downs for loads that may have shifted during transit.

Blocking under the red iron protects the slab from damage during the unloading process. It also facilitates the placing of slings or cables around the members for later lifting and allows members to be bolted together into sub-assemblies while on the ground. Extra care should always be exercised in the unloading operation to prevent injuries from handling the steel and to prevent damage to materials and the concrete slab.

If water is allowed to remain for extended periods in bundles of primed parts such as girts, purlins, etc., the pigment will fade, and the paint will gradually soften reducing its bond to the steel. Therefore, upon receipt of a job, all bundles of primed parts should be stored at an angle to allow any trapped water to drain away and permit air circulation for drying. Puddles of water should not be allowed to collect and remain on columns or rafters for the same reason.

All primer should be touched up as required before erection!

SECTION 3

UNLOADING

A tractor with loading forks and/or an all-terrain forklift is necessary for unloading the components of a metal building. Care should always be taken to avoid damaging material.

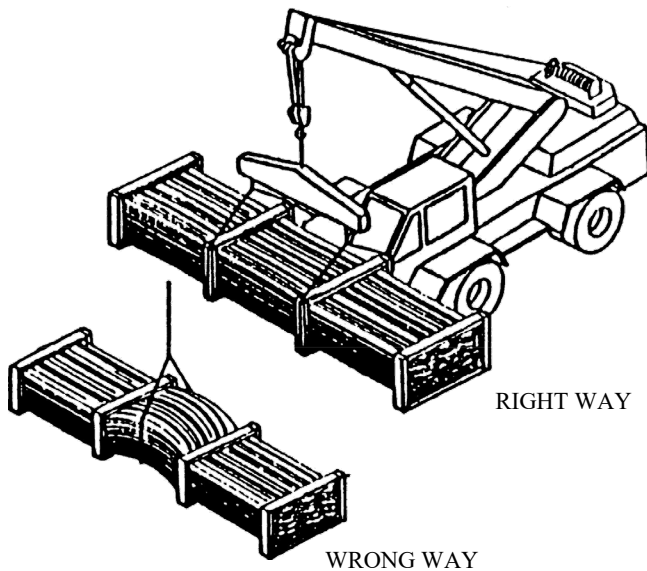
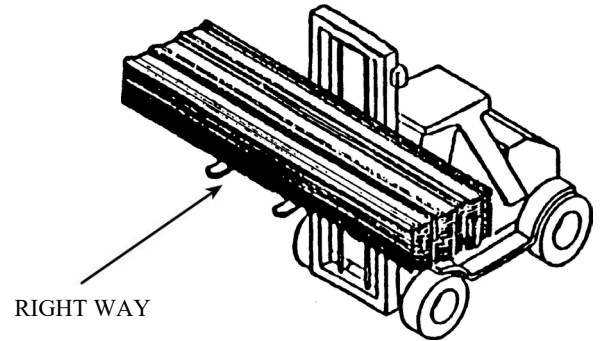
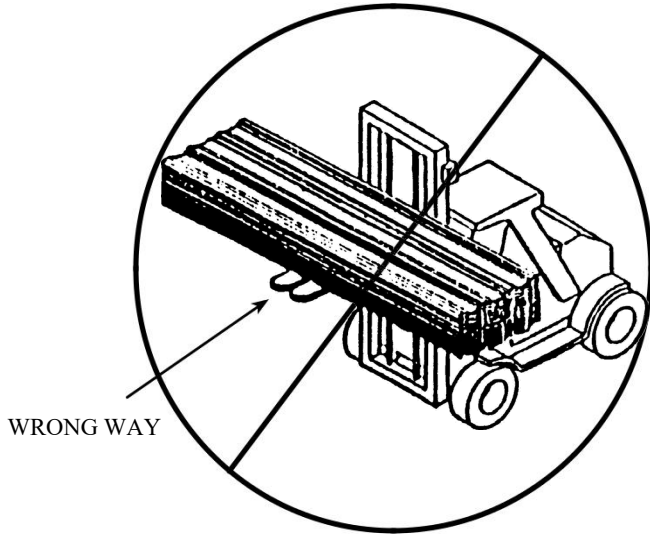

NOTE! Long panels may be difficult to handle by lifting the bundle from beneath.

Always spread the forks as wide as possible to prevent panels from bending. Even with the forks as wide as possible, it still may be necessary to lift certain loads with a spreader bar to avoid damaging material.

SECTION 3

CABLE TENSION AND HOOK HEIGHT

Tension and hook height for lifting weights at various angles are shown by the diagrams below;

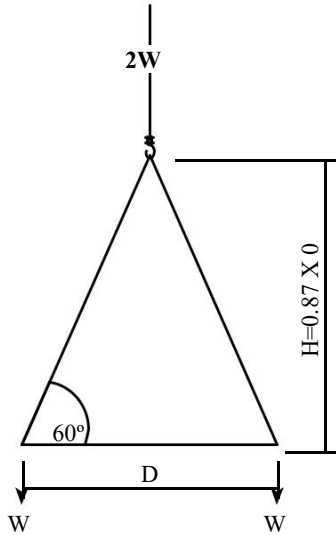

LIFTING SLING @ 60°
TENSION IN ROPE IS $1.15 \times W$

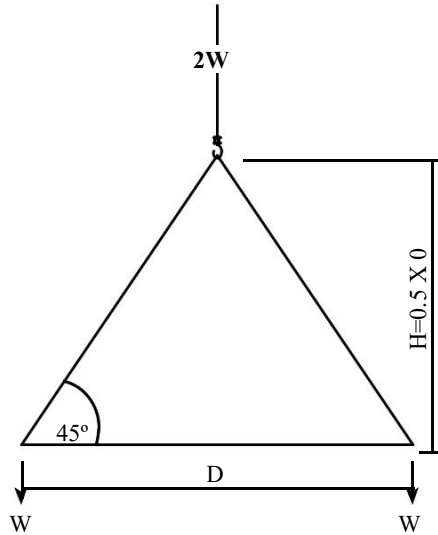

LIFTING SLING @ 45°
TENSION IN ROPE IS $1.41 \times W$

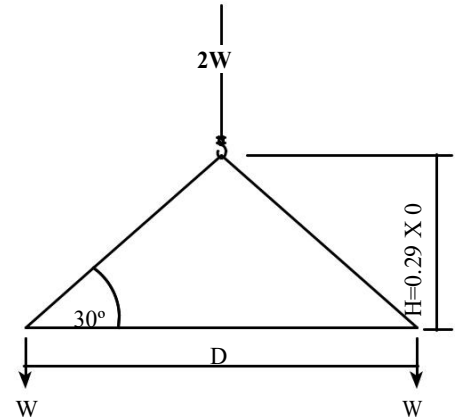

LIFTING SLING @ 30°
TENSION IN ROPE IS $2 \times W$

Notice how the cable tension increases as the lifting angle is decreased. It is of interest or note that if this angle is reduced to 15° , the cable tension is 3.9 times the vertical lift; at 10° it is 5.7 and at 5° it is 11.5. When tension in the cable increases, the compressive or buckling load on the peak rafter section also increases. **Slings with low lifting angles should therefore be avoided both to protect the cable and to prevent buckling the rafter.**

SAFETY NOTE! Check wire rope for broken strands, broken wires, and kinking. Replace damaged, unsafe rope immediately. Always use equipment with an adequate safety margin over the lifted load!

SECTION 3

WALL AND ROOF PANELS

SSBC wall and roof panels including color coated, galvalume and galvanized, provide excellent service under widely varied conditions. All unloading and erection personnel should fully understand that **these panels are quality merchandise which merit cautions care in handling.**

Under no circumstances should panels be handled roughly. Packages of sheets should be lifted off the truck with extreme care taken to ensure that no damage occurs to ends of the sheets or to side ribs. The packages should be stored off the ground sufficiently high to allow air circulation underneath the packages. This avoids ground moisture and deters people from walking on the packages. One end of the package should always be elevated to encourage drainage in case of rain.

All stacked metal panels are subject, to some degree, to localized discoloration or stain when water is trapped between their closely nested surfaces. *SSBC* exercises extreme caution during fabricating and shipping operations to ensure that all panel stock is kept dry. However, due to climatic conditions, water formed by condensation of humid air can become trapped between stacked sheets, Water can also be trapped between the stacked sheets when exposed to rain. This discoloration caused by trapped moisture is often called wet storage stain.

The stain is usually superficial and has little effect on the appearance or service life of the panels as long as it is not permitted to remain on the panels. However, moisture in contact with the surface of the panels over an extended period can severely attack the finish and reduce the effective service life. Therefore, it is imperative that all panels be inspected for moisture upon receipt of the order. **If moisture is present, dry the panels at once and store in a dry, warm place.**

CAUTION: Care should always be taken when walking on panels. Use safety lines and nets when necessary! Panels are slippery. Oil or wax applied to the roof and wall panels for protection against weather damage will make them a very slippery surface. Wipe dry and oil that has puddled from bundles stored on a slope. Dew, frost or other forms of moisture greatly increase the slipperiness of the panels. Always assume panel surfaces are slippery and act accordingly.

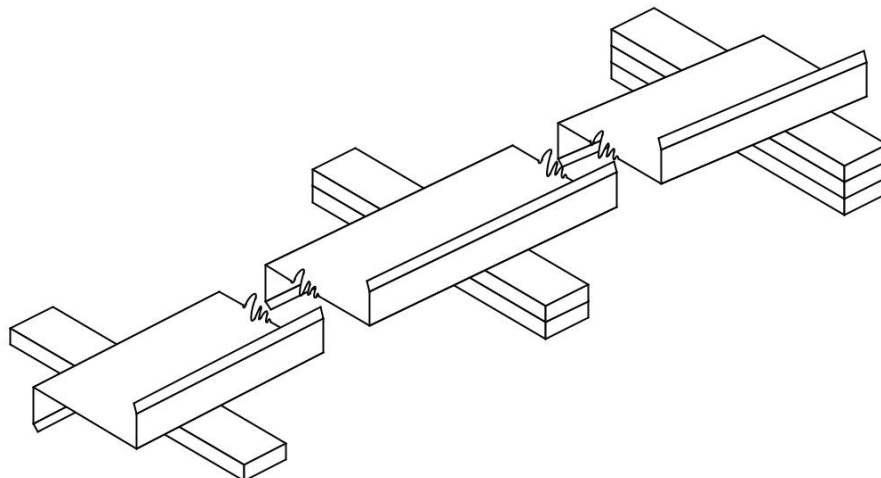

SECTION 3

WALL AND ROOF PANELS (CONTINUED)

Use **wood blocking** to elevate and slope the panels in a manner that will allow moisture to drain. Wood blocking placed between bundles will provide additional air circulation. Cover the stacked bundles with a tarp or plastic cover leaving enough opening at the bottom for air to circulate.

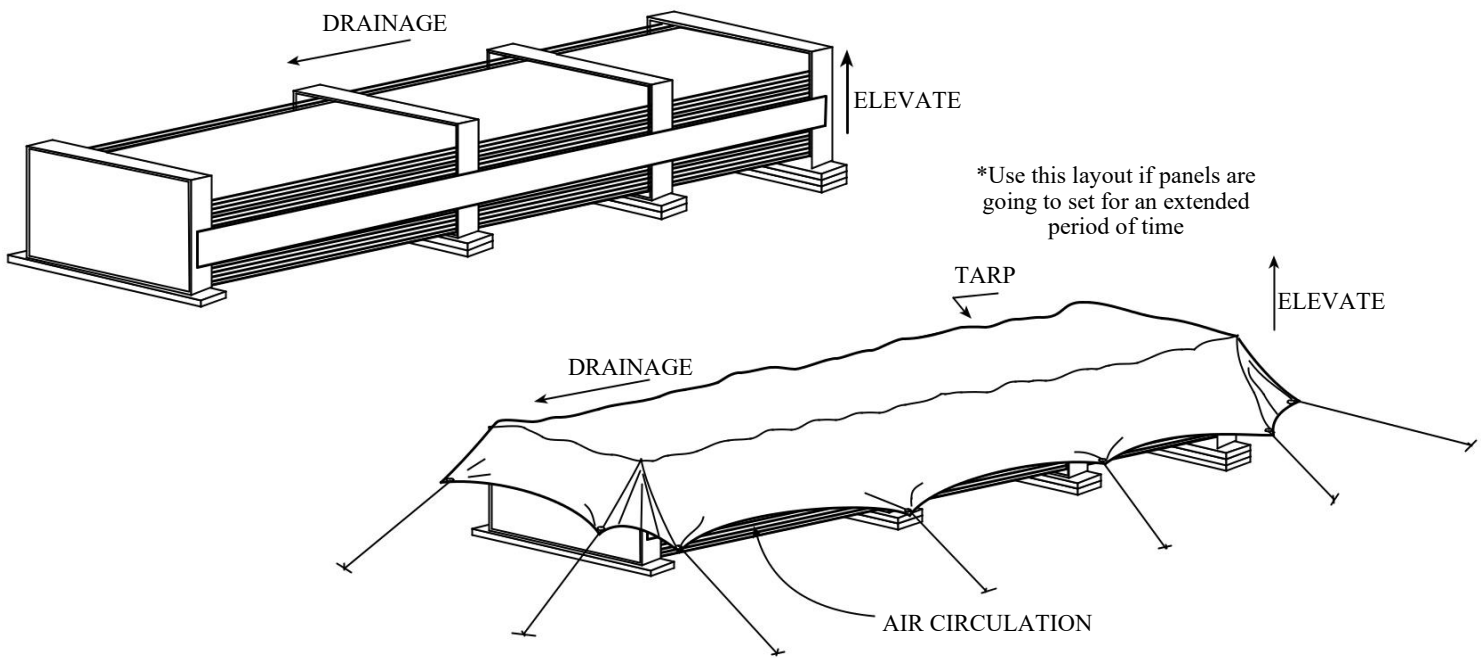

When handling or uncrating the panels, **lift rather than slide them apart.**

Burred edges may scratch the coated surfaces when sheets are slid over one another. Never allow panels to be walked on while on the ground.

Rough and improper handling of a panel is inexcusable and a prime example of poor job supervision.

NOTE! Use gloves when handling metal panels to prevent hand injuries. Be aware of the dangers of handling panels on a windy day. A large panel can catch enough wind to knock a worker off of his feet, even at ground level.

STRUCTURAL FRAMING PRECAUTIONS

The layout, assembly and erection of steel should be completed by responsible personnel, experienced in rigging, and handling light steel members in a safe manner. Improper handling can easily result in injury, delays, and unexpected added costs. This is particularly true when raising assembled trusses.

KEEPING ERECTION COSTS DOWN

Minimum costs should be obtained when the following conditions are met during the erection of a building:

1. When safety practices are discussed and initiated in advance of any work procedure.
2. When the overall work of erecting the building is divided onto individual jobs, and when each job is assigned (in proper sequence) to teams of workers consisting of from two to four workers each.
3. When individual workers are properly trained and instructed in advance as to what they are to do and the safest way to do it. This eliminates time wasted while waiting to be told what to do next.
4. When building parts are properly laid out according to advanced planning to avoid lost time in repetitive handling or in searching for specific items.
5. When as many parts as can be safely raised in a single lift are bolted together in sub-assemblies on the ground where assembly work is faster and safer, thereby, requiring fewer lifts and fewer connections to be made in the air.
6. When erection of the steel framework starts at one end and continues bay by bay to the other end of the building.
7. When the first bay is completed, the individual frames are erected and tied together by skeleton purlins, and the fill-in purlins are installed after the costly lifting equipment has been released.
8. When tools and equipment of the proper kind, in good, safe condition, are available in sufficient quantity.

ERECTION OF PRIMARY AND SECONDARY STRUCTURE

GENERAL INFORMATION

Many methods and procedures are in use for erecting the structural portion of metal buildings. The techniques of raising frames vary from erecting small truss frames and endwall frames in units to erecting the larger 40' foot & 50' foot wide truss frames. The erection methods used depend strictly on the type of building, the available equipment, the experience level of the crews, and the individual job conditions.

The variation in these factors preclude the establishment of a firm or specific set of erection rules and procedures. Consequently, the erection operation must be tailored by the erector to fit individual conditions and requirements. However, there are certain erection practices, pertaining to structural members, which are in general use and have proven sound over the years. Descriptions of these follow.

Erectors are cautioned not to cut primary members (Truss frame column, rafters, bottom cord, kingpins, end wall columns and rafters). These are the primary support members for the frame and are designed as such. Any cutting of these members may affect the structural stability. A representative of ours should be consulted prior to attempting alterations of these members.

NOTE! Do Not install any material if its quality is in question. We will not be responsible for costs incurred associated with the installation and/or removal of same.

NOTE! In no case should building erection be started on green concrete. Anchor bolts may pull loose, concrete spall (chip out along edges) may occur and equipment may crush or crack slab. Normal Portland cement concrete should cure at least seven days and high-early-strength concrete at least three days before the structural columns are erected. Special circumstances may require even longer curing periods, consult the project engineer, not **SSBC**, on foundations questions, unless **SSBC** has provided the Engineered Footing and Foundation Plans.

RECOMMENDED TOOLS

When buying tools for building erection, it is recommended that only industrial rated, top-quality tools be purchased. Experience shows that lighter duty tools, although cheaper initially, will not hold up satisfactorily, and in the long run, will cost more, not only in repairs, but also in lost time. High speed drill bits are always recommended since carbon steel bits will not give satisfactory service. Most erectors find that short jobbers length bits are more economical and rugged than standard length bits.

The smaller hand tools are particularly difficult to maintain because of breakage, losses, pilferage, etc. Some erectors require the workers on the crew to furnish their own tools in this category. Others issue the tools to individuals or foremen who are held responsible and liable for them. Since work rules and customs differ according to localities, each erector should establish a definite policy which is acceptable to his workers while protecting his property.

Maintaining equipment and tools in safe and first-class condition results injuries, lowers replacement expense, and stimulates workers to take better care of equipment and take greater pride in their work.

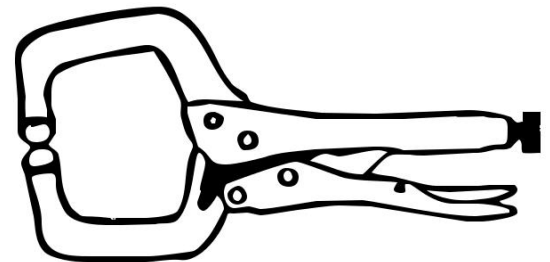
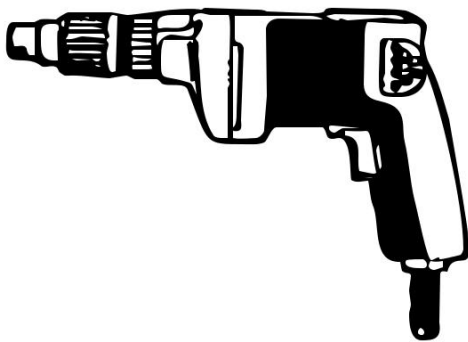

NOTE! Make certain that the correct tool is available and used for each phase of building erection. Improper tool usage results in employee injury. All tools should be OSHA approved for commercial use.

SECTION 4

ATTACHING COLUMNS TO CONCRETE

Attach columns to anchor bolts using a Simpson Steel supplied BC-6 base clip and (2) A325 bolts as illustrated below. Torque bolts to approximately 100-foot pounds of pressure or if you do not have a torque wrench available tighten bolts to a snug fit. All 8" x 3 1/2" columns and overhead door jambs will attach using the BC-6 clips, 8" x 2 1/2" jambs for windows and walk doors will attach using UP-8 clips provided by Simpson Steel unless otherwise noted.

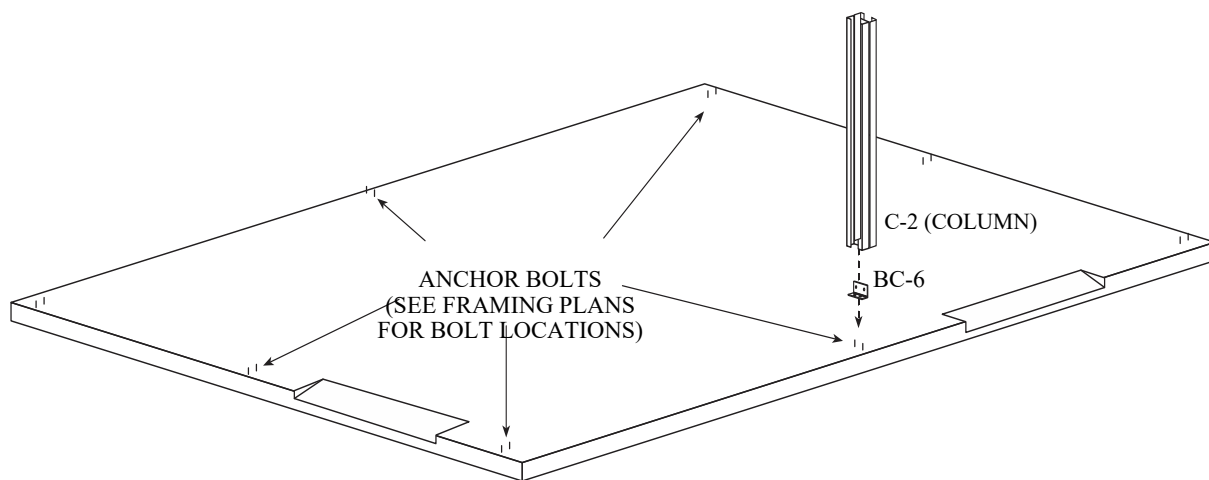

BACK-TO-BACK BC-6 CLIP ATTACHMENT DETAIL

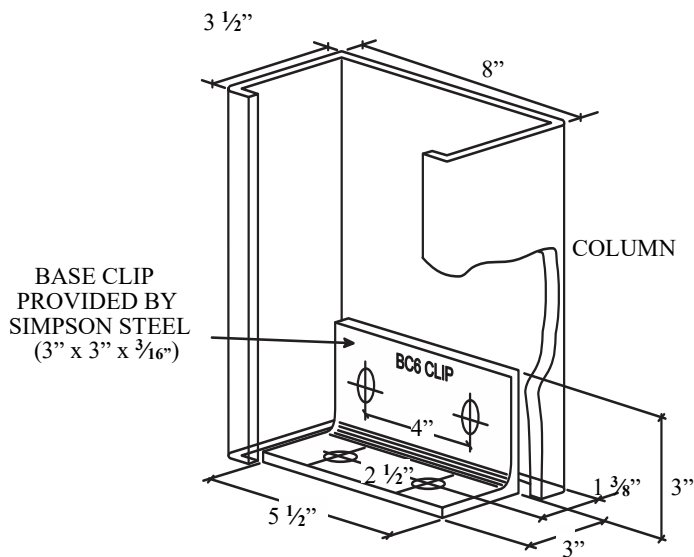

DIMENSION DETAIL

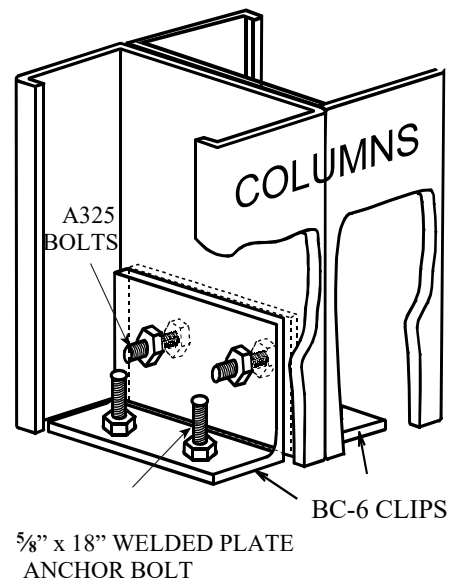

ATTACHMENT DETAIL

SECTION 4

RAISING TRUSS FRAMES

Attach the UP-8 girt clips to all columns and overhead door jambs using (4) IMPAX 4.5 screws (see page 38 for details). Bolt the BC-6 base clips to the base of all of the columns and overhead door jambs using (2) A325 bolts and washers. Followed by bolting the CCCL clip and the CCCR clip to the top of the C-1 columns using (2) A325 bolts, nuts and washers (see page 31 for details). Bolt the Endwall Peak Clip (EPC) to the top of the C-3 center column. If you have an overhead door centered in the end wall there will not be a C-3 center column. In this case, see framing plans for instructions. These steps should be done before the columns are raised into place. The truss frame columns (C-2's) are usually erected first. Followed by the endwall corner columns (C-1's) then the center column on end wall (C-3).

Although several methods are used to erect truss frames, it has been found most satisfactory to erect the columns first. Tie them together with the girts using (4) IMPAX 4.5 screws through the girt into the UP-8 clip followed by tightening of the anchor bolts. On small spans and short eave heights, columns can often be set in place by hand without the use of hoisting equipment.

Temporary bracing should always be installed as soon as sections are lifted in place.

Base angle should be attached using Tapcon or any other concrete fastener that is a minimum of 1/4" in diameter, 1 3/4" in length, and rated at 1,500 lb. pullout. The spacing of the fasteners should be at 3 ft on center max. Concrete fasteners are **NOT** included with the kit. **We do not recommend Hilti nails, BUT Hilti Kwik-con ii style fasteners are fine.** Drive pins work well.

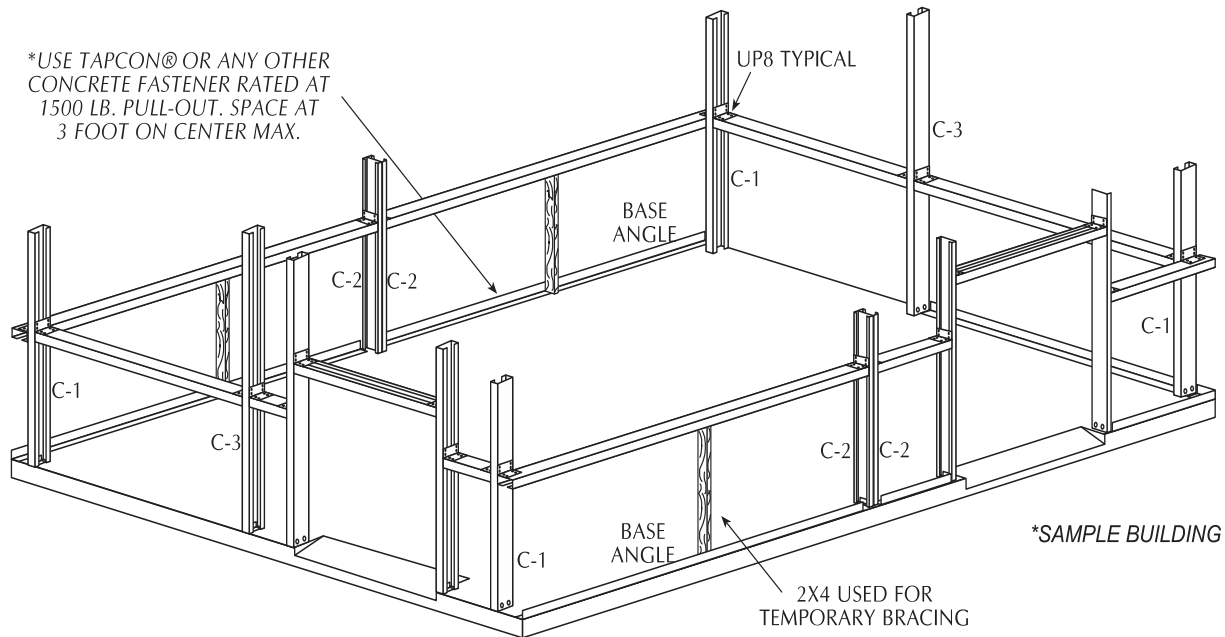

NOTE! Complete sets of erection drawings are furnished with every building. Your plan is specially prepared for each individual building and should be strictly adhered to. Familiarize yourself and crew with these drawings prior to start-up.

CABLE BRACING

RAISING TRUSS FRAMES (CONT.)

After the columns have been erected, the ground assembled truss (see truss detail for clip location) is hoisted into place and connected to the columns using (4) A325 bolts, nuts and washers. Temporary bracing (such as wood 2" x 4" or 2" x 4" angle (to be re-used)) should be attached along the center connection of the bottom S-3 chords. This will prevent swaying of the two halves of the truss. Trusses are designed for vertical support and will be horizontally supported, once installed, by the flange bracing.

USE A325 BOLTS, NUTS AND WASHER FOR ALL TRUSS FRAMING CONNECTIONS ALL BOLTS FURNISHED WITH 1 WASHER AND 1 NUT.

USING (2) IMPAX 4.5 SCREWS, ATTACH UP-4 PURLIN CLIPS TO B1 AND B2 AT SPECIFIED LOCATIONS ON FRAMING PLANS

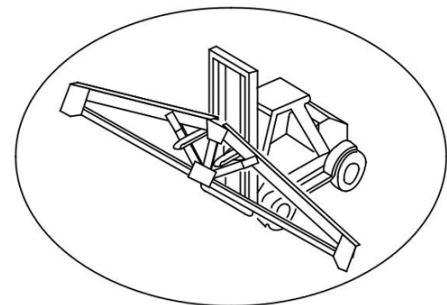
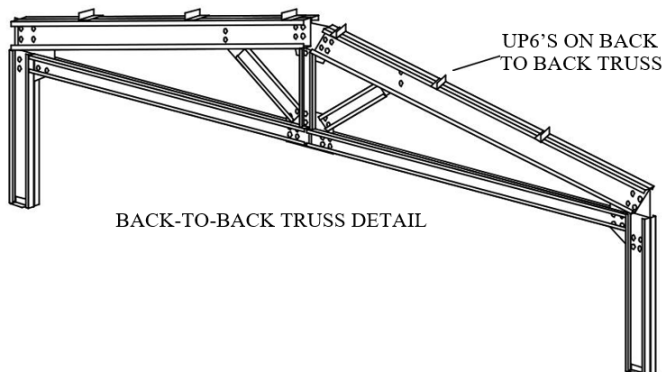
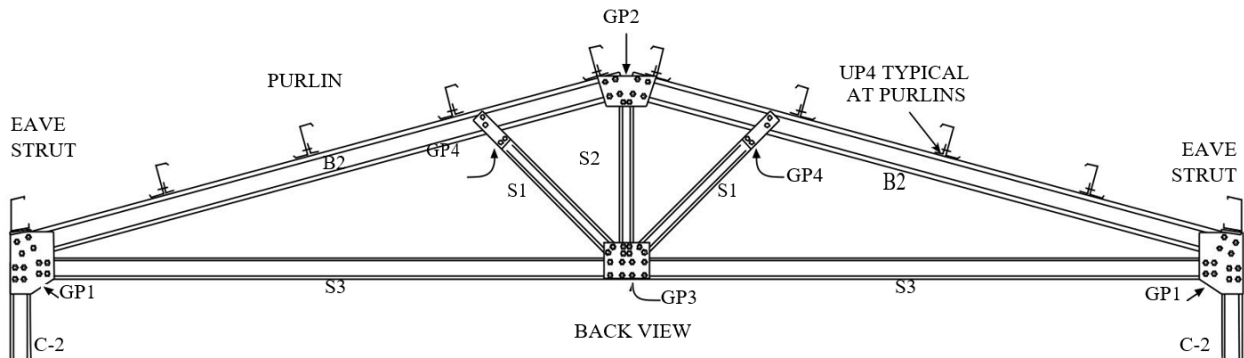
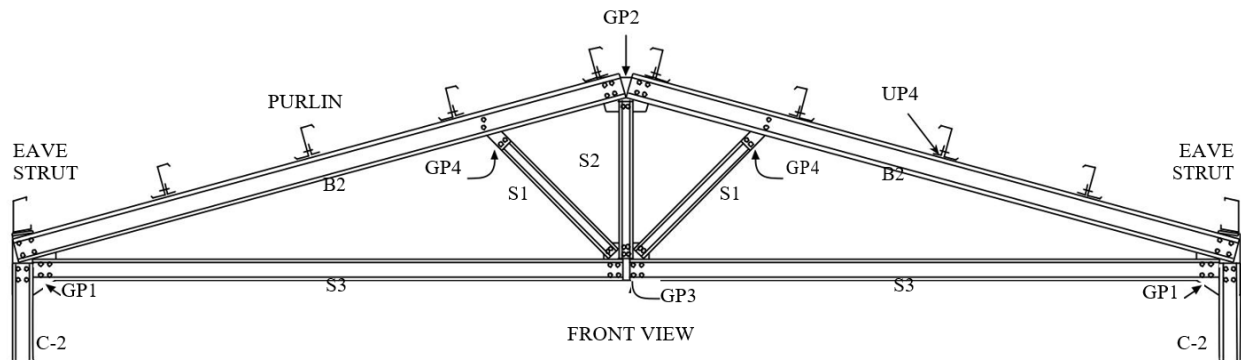

The hoisting equipment should never be released from the truss until the frame is adequately braced, so it cannot buckle or tip in the longitudinal direction of the building.

NOTE! Stay well in the clear of loads being moved by any type of lifting equipment.

*Depending on your building and the area you are in, you may require a back-to-back truss. In this case you have double columns and rafters but single joining plates.

RAISING TRUSS FRAMES (CONT.)

A second method (while not recommended), when equipment is limited, is that after the column is erected with the GP-1 bolted to the column, the bottom cords (S-3) are raised into position and bolted to the GP-1, then, when the free end of the bottom cords are supported by any safe method (such as an adequate wood frame, or a metal scaffold, properly braced and of satisfactory capacity), bolt the free ends together with the GP-3 plate. Then bolt S-1 and S-2 members to the GP-3 plate. Bolt the GP-4 plate to the S-1's bolt GP-2 to the S-2, then raise the top rafter (B-2) into place by bolting one end. Using 1 bolt through the GP-1, then raising the free end and bolting to the GP-2 at peak. After peak connections are bolted into place bolt the GP-4 to the B-2, then put the remaining bolts in rafter to GP-1 connection.

Attach the UP-4 purlin clips to rafters using (4) IMPAX 4.5 screws at the location shown on the cross section of truss on erection drawings. The same method can be used for raising the endwall rafter (B-1). Raise one end of the B-1 rafter up to the corner column clip, use (1) A325 bolt, nut and washer to bolt the rafter to the clip. Raise the free end to peak and bolt to EPC using A325 bolts, nuts and washers. After peak is secure, put the remaining bolts in. (**SEE DETAILS BELOW**)

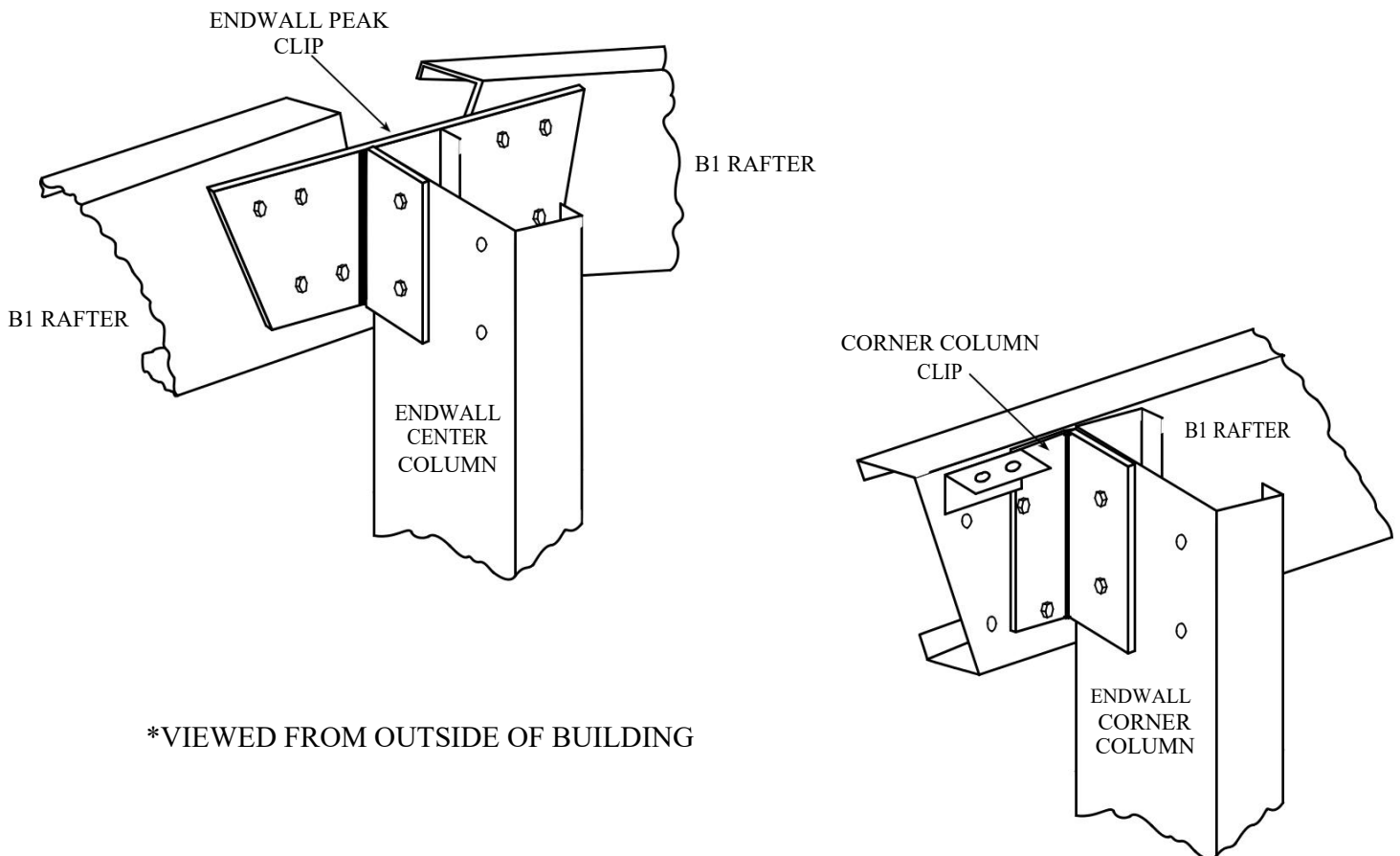

SECTION 4

RAISING TRUSS FRAMES (CONT.)

If you have more than a 2-bay building, such as a 3, 4 or 5 bay building, raise the first truss into place, followed by the second truss. When the second truss is in the air, tie the two trusses together with a purlin on each side of the ridge. Do this in each bay, as the truss is erected. In the case of a 2-bay building, the purlin will go directly from truss to end wall rafter. Before the rest of the purlins are installed, bolt the eave struts (ES) into place using (2) A307 bolts, nuts and washers. There are holes for the eave struts in the B-2 rafter or GP-1 clip and the corner clips. Holes will have to be field drilled in the case where the eave strut is connected directly to the rafter. After all the purlins are in place, connect the flange braces. (See roof framing plan for purlin run that receives the braces). Connect a UP-6 clip to the S-3 using (4) IMPAX 4.5 screws. The flange braces will be in 20' lengths, field cut to length shown on parts list. Using a vise grip, clamp the flange brace to UP-6 clip, raise opposite end up to face of purlin and put (4) IMPAX 4.5 screws through the angle into purlin. The end that is clamped to the UP-6, uses (4) IMPAX 4.5 screws at the connection also.

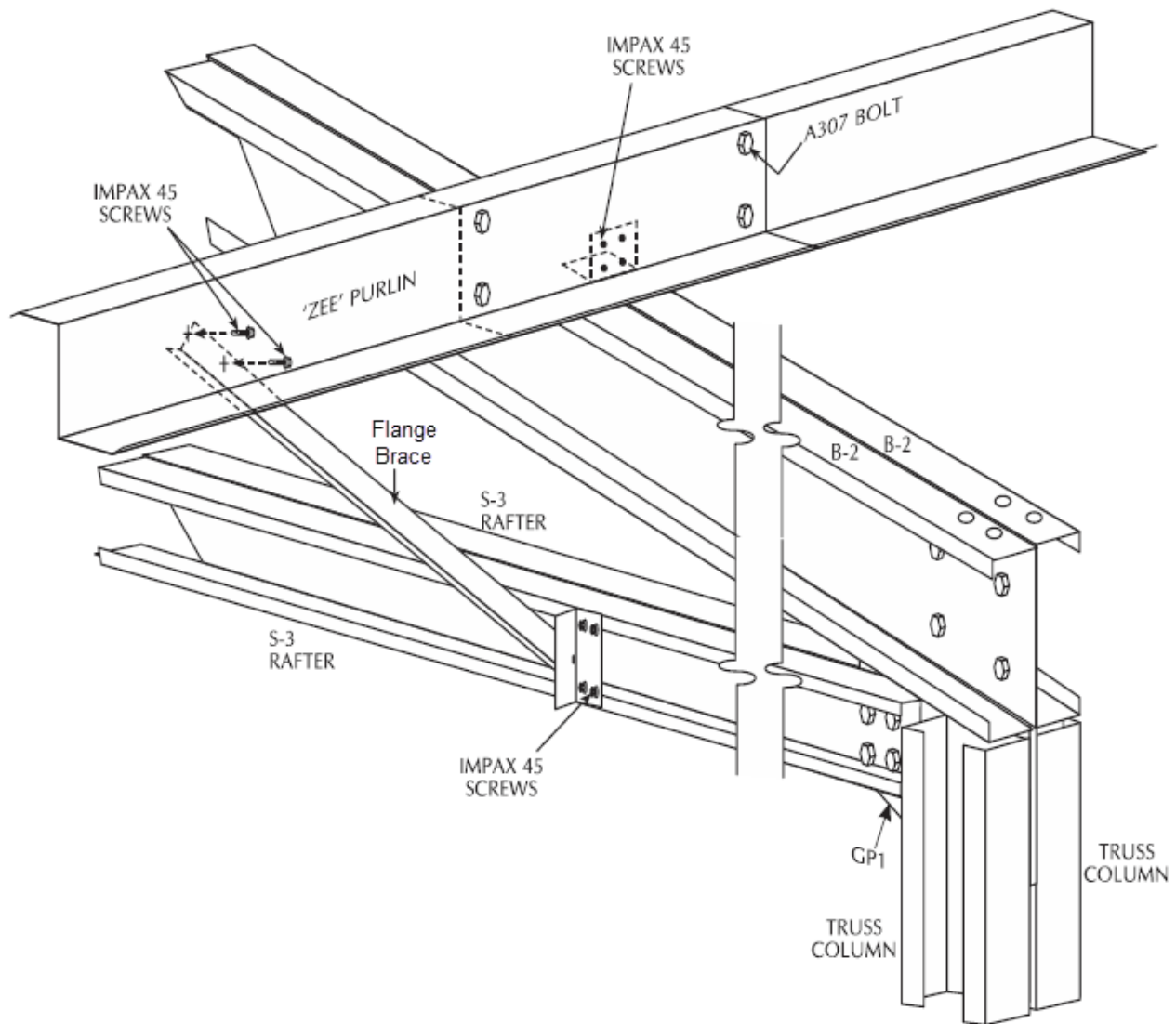

SECTION 4

TYPICAL TRUSS FRAME STRUCTURE

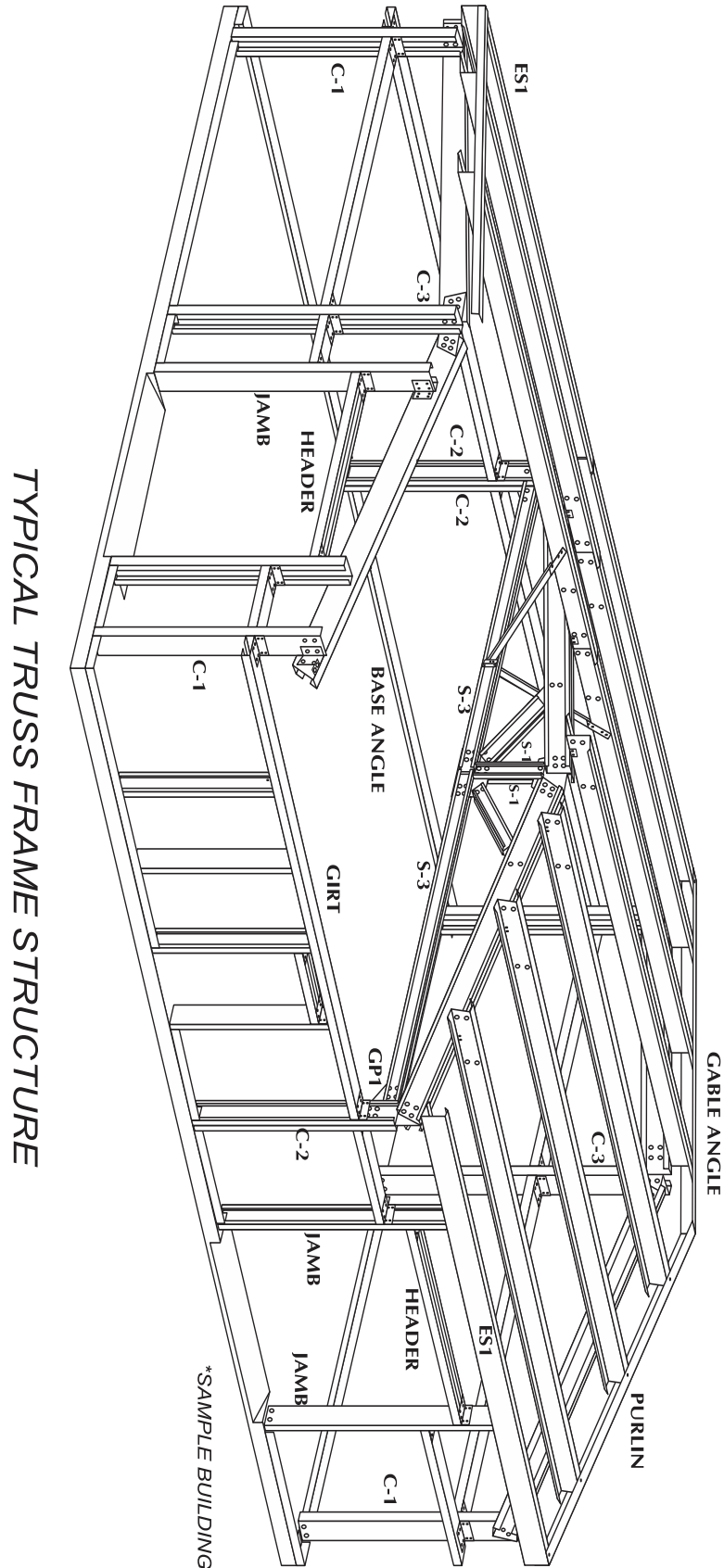

Piece marks shown on pictorial as shown on framing plans.

SECTION 4

TRUSS FRAME OVERHANG

To accomplish the overhang on the end wall, the purlins are extended out the distance of the overhang. Attach the 4" x 2" angle (detail A below) to the bottom of the purlin at the steel line with IMPAX 4.5 screws. At the end wall, an 8 1/8" open channel (OC-1) is used to cap the eave strut, the first purlin and extend out the distance of the overhang. This is attached with IMPAX 4.5 screws. From the OC-1 to the peak, a 4" x 2" angle (detail B below) is used on the bottom of purlin on the outside edge using the IMPAX 4.5 screws. For the overhang on the sidewall, (2) 8 1/8" open channels (OC-3) are screwed back-to-back with IMPAX 4.5 screws. Then screw down to the top of the rafter (B-2) with (2) IMPAX 4.5 screws. An 8"x 2 1/2" x 16 ga. 'C' channel (OC-2) is used to cap off the sidewall overhang. It will fit inside the OC-1 and OC-3's. Fasten with IMPAX 4.5 screws. (**SEE DETAIL BELOW**)

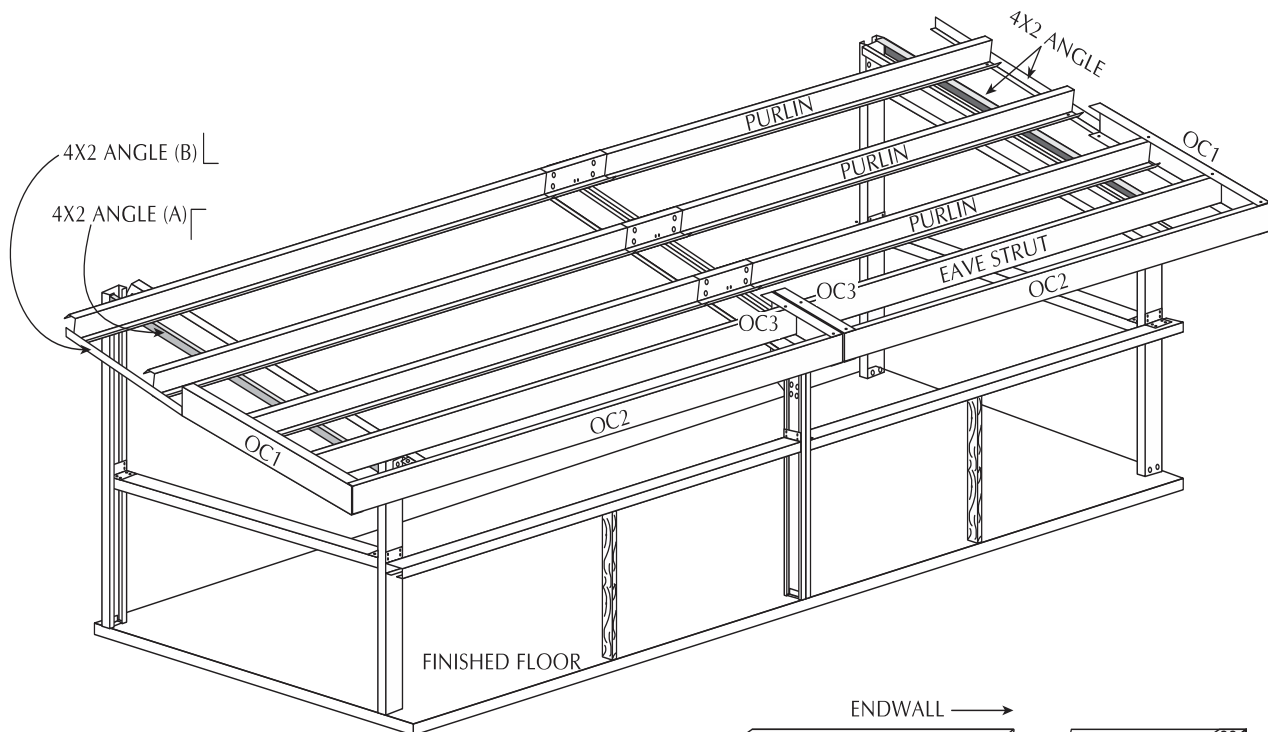

* SAMPLE BUILDING
WITH OVERHANG DETAIL

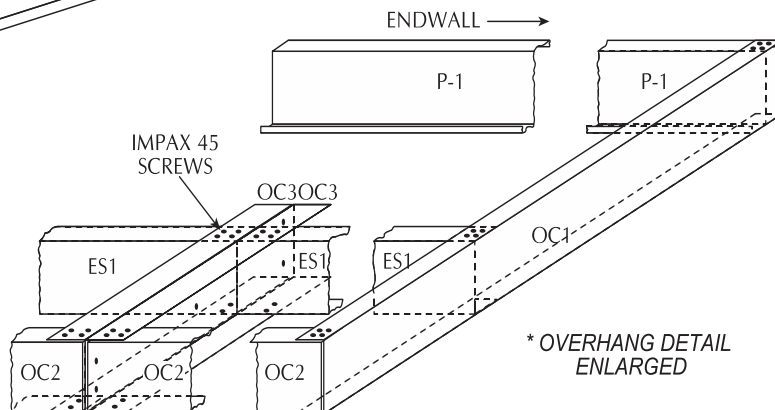

SECTION 4

OVERHANG DETAIL
(SIDEWALL ONLY)

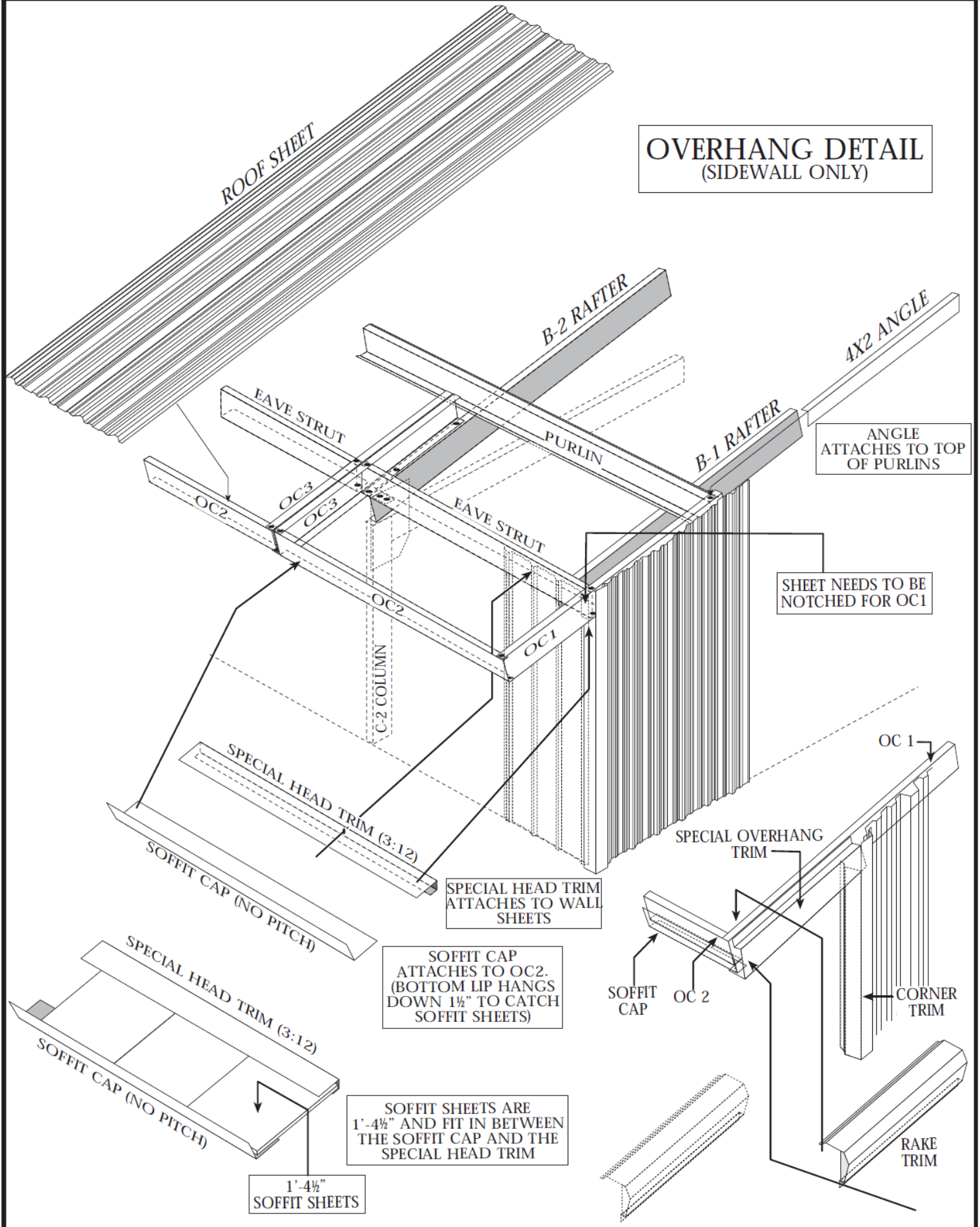

SECTION 4

OVERHANG DETAIL (ENDWALL ONLY)

SOFFIT SHEET
(CUT 3" SOFFIT SHEET IN
HALF AND USE ON
BOTH ENDS.)

SOFFIT SHEET
(SLIDES IN CHANNEL
CREATED BY SOFFIT CAP
AND HEAD TRIM)

1'-6"

4X2 ANGLE
(ATTACH TO BOTTOM
OF PURLINS)

HEAD TRIM
ATTACH TO BOTTOM
OF PURLINS & EAVE STRUT

EAVE STRUT

SOFFIT CAP
(ATTACH TO 4X2 ANGLE)

(ATTACH SPECIAL OVERHEAD
TRIM TO EAVE STRUT
FACE. ATTACH CORNER TO
SOFFIT CAP CORNER.)

SPECIAL OVERHANG
EAVE TRIM

SOFFIT CAP

SPECIAL
OVERHANG TRIM

CORNER TRIM

SIMPLE EAVE TRIM
ATTACHES TO TOP OF
EAVE STRUT COVERING THE
TOP OF THE WALL SHEETS

EAVE STRUT

SIMPLE
EAVE TRIM

WALL SHEETS

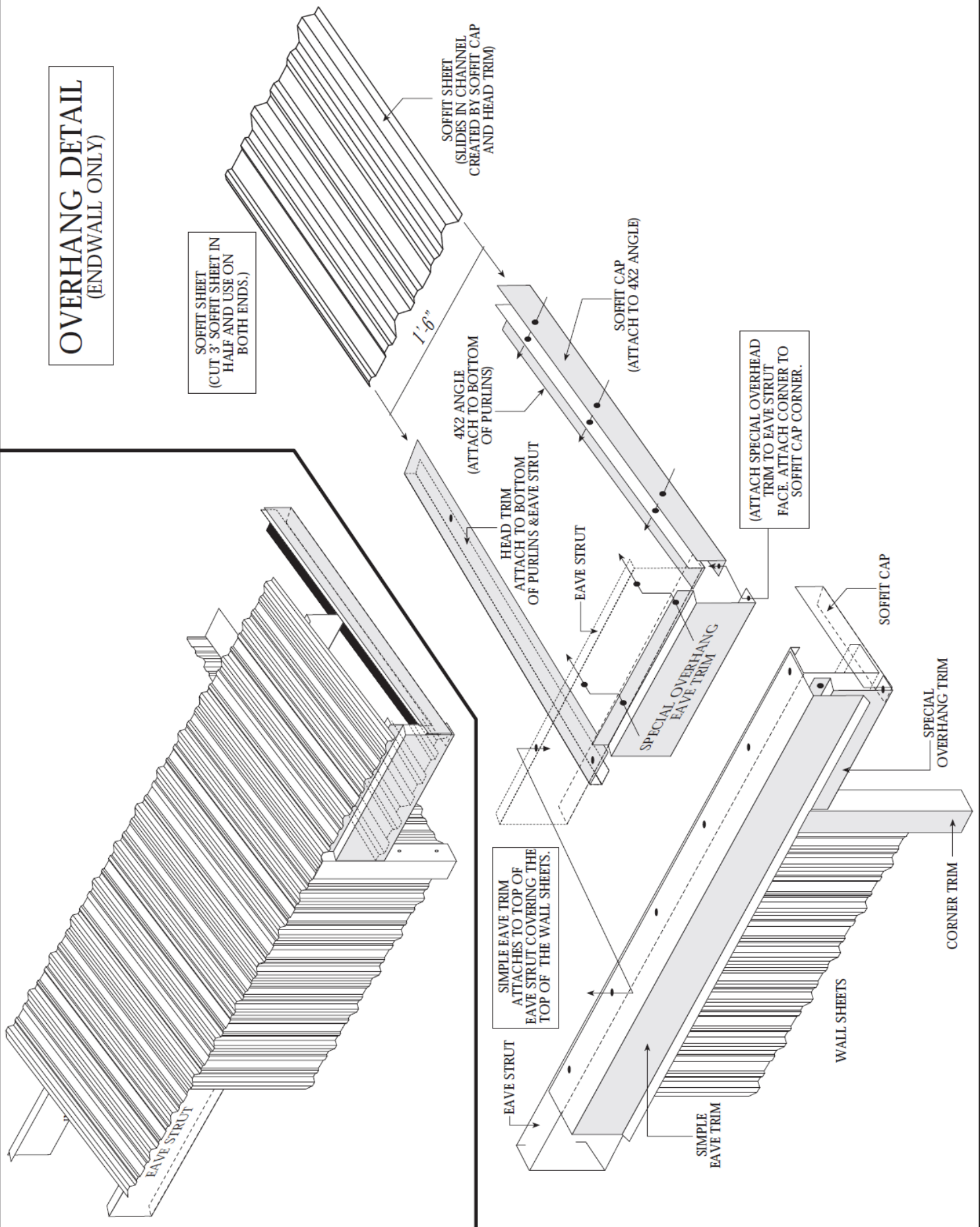

SECTION 4

TYPICAL SECONDARY FRAMING CONNECTIONS INTERIOR BAY PURLIN/GIRT FRAMING

We utilize uneven legs on our "Z" shapes to improve erection time and to increase the overall strength of the member. Since the "Z"s are designed to nest, *the erector must be aware that the 2 1/8" flange should be up on odd number bays and down on even number bays*, to allow the members to seat properly. **The bottom "Z" has the wide leg (2 3/8") down to allow for the narrow leg (2 1/8") of the top "Z" to nest properly.**

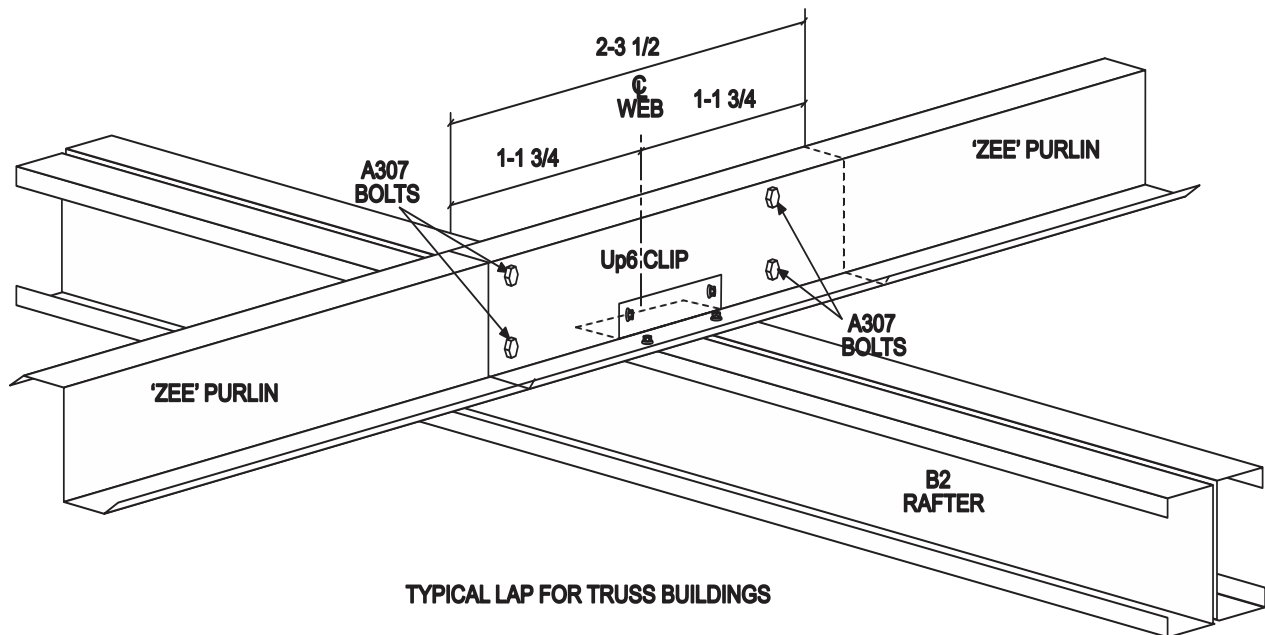

If the Purlins are not 'nested' correctly, the holes will not line up.

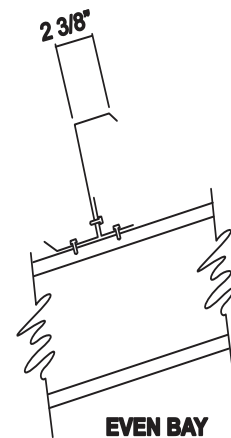
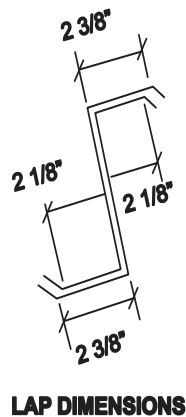
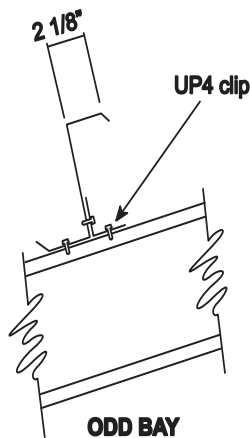

NOTE! BOLTS SHOWN HERE REQUIRED TO BE TIGHTENED TO SNUG FIT CONDITION ONLY!

SECTION 4

TYPICAL SECONDARY FRAMING CONNECTIONS

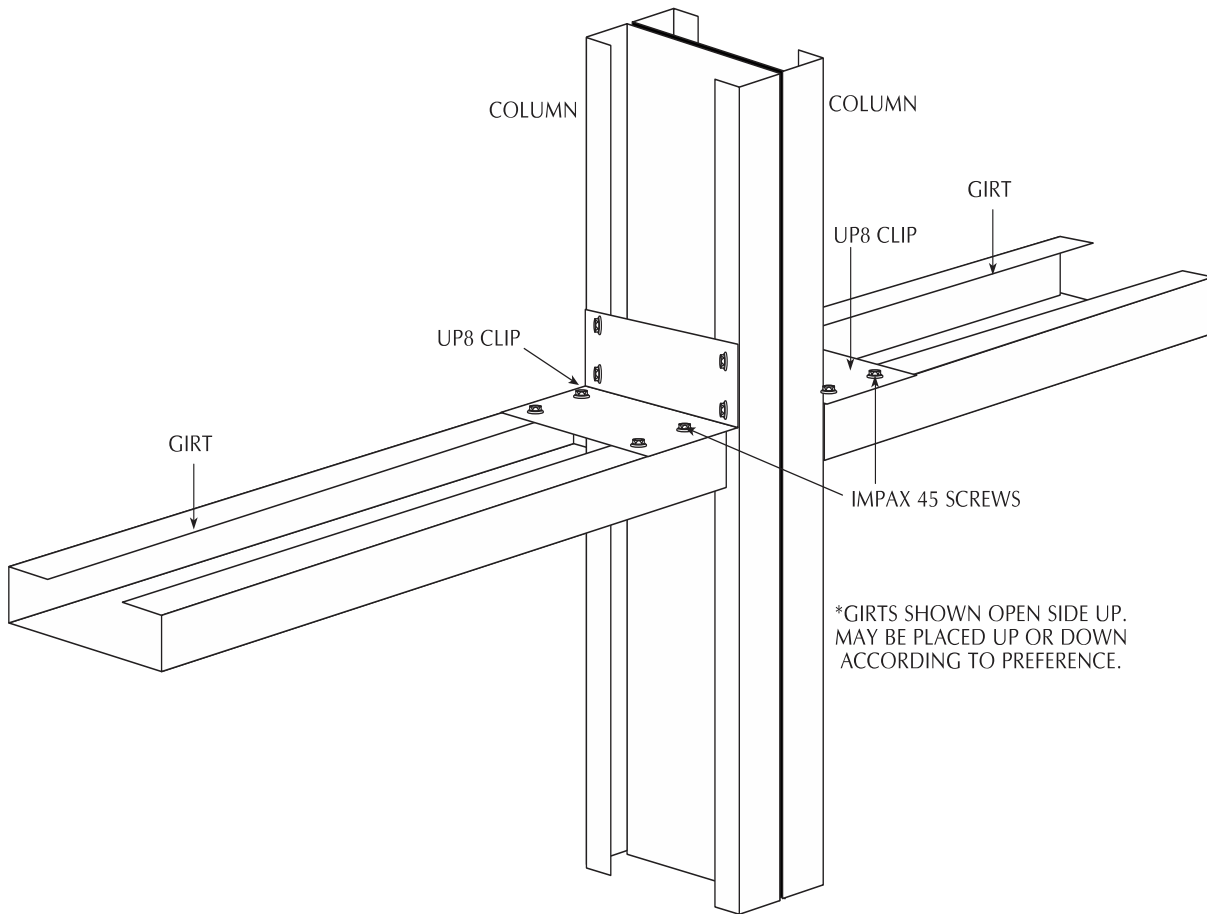

*Girts are ordered at $\frac{1}{2}$ " shorter than opening they are to be framed in. You should have a $\frac{1}{4}$ " gap between uprights and girts. Girts can be positioned open side up or down.

NOTE! The flush girt connection requires four (8) IMPAX #4.5 screws. A girt can be placed with the open side up or down. All drawings show girt with open side down.

SECTION 4

RAKE / GABLE ANGLE WITH & W/O OVERHANG

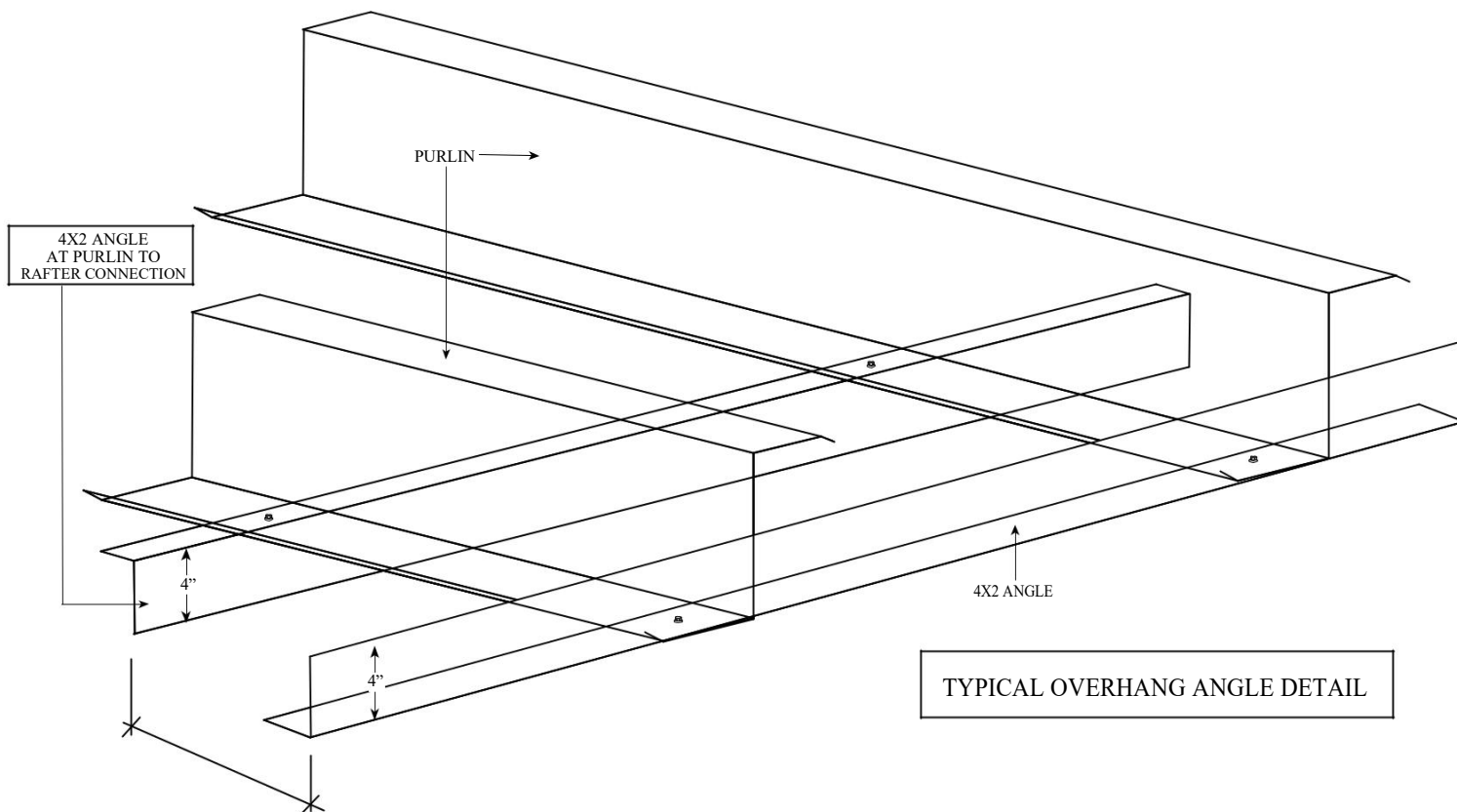
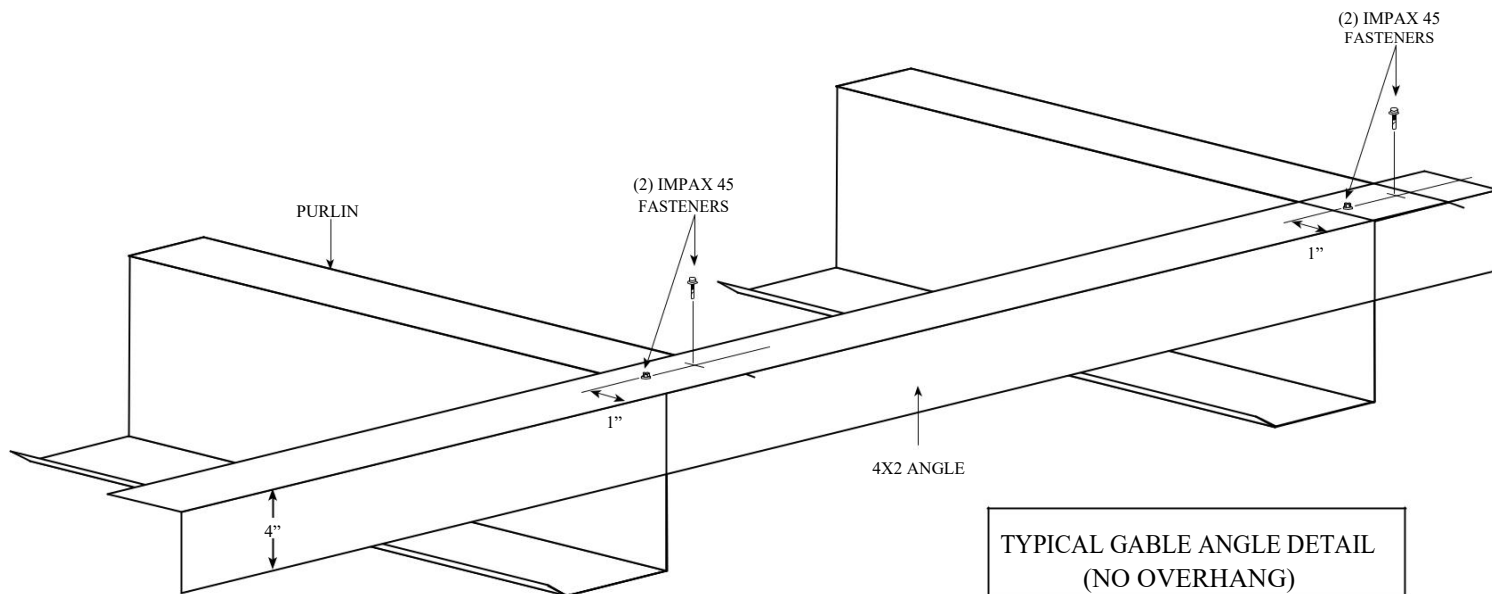

NOTE! Each worker should be trained to use the safest and most productive erection techniques. **SAFETY FIRST!**

SECTION 4

SHEETING

All of the primary and secondary framing should be erected, plumbed and the bolts properly tightened before the sheeting of the building is started. Framed openings should also be installed, plumbed, squared and tightened before sheeting begins. Most people use a come-along with a chain attached to the top of one column and the bottom of the opposite column to pull the building square until sheeting is attached. Simpson Steel does not endorse this or any other method of ‘squaring’ up the building. This is left up to the building owner.

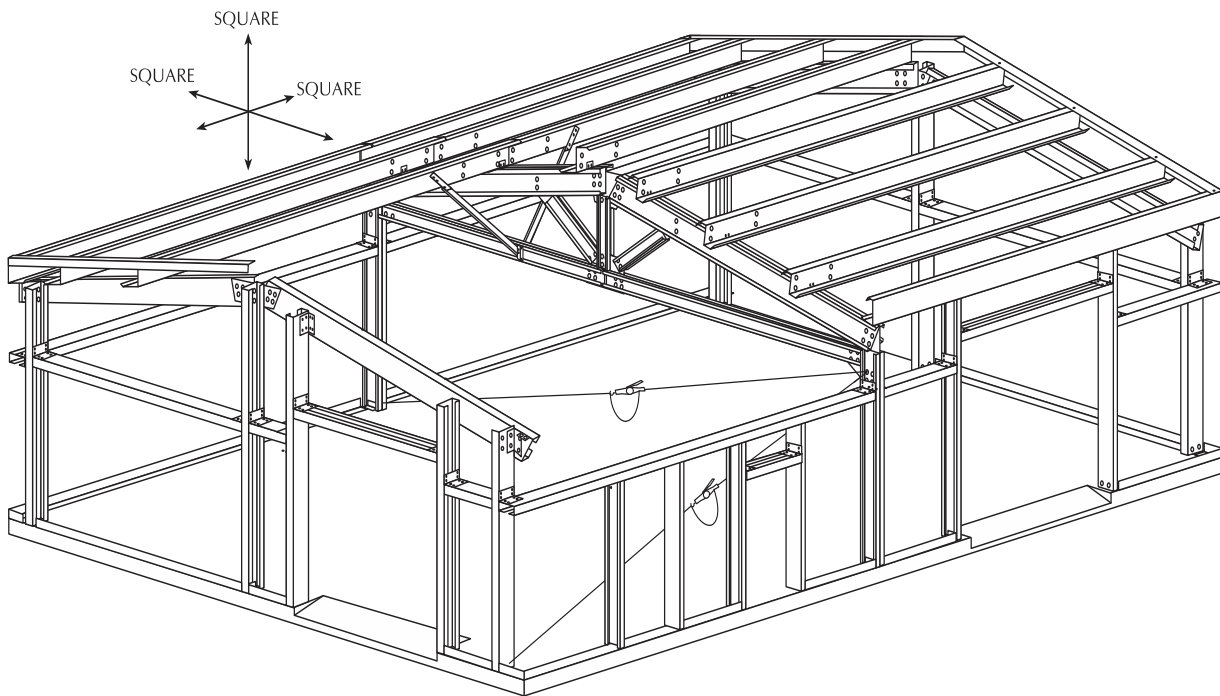

*NOT FULLY FRAMED FOR VIEWING PURPOSES

*SAMPLE BUILDING

SSBC wall and roof panels are quality merchandise and should be handled with care. When unpacking panels, pick them up and apart; never slide one panel over another. When lifting panels, support long panels to prevent buckling.

This section contains erection instructions for exposed fastener metal panels only.

NOTE! Workers should always use gloves when lifting sheets.

SECTION 4

“PBR” PANELS

The “PBR” panels are designed for roof and wall application. The profile is continuous except for the addition of the support leg on the leading edge on one side. Erection of this panel requires that the proper direction of its application be established. The support leg allows for better nesting with the overlapping rib of the next panel. As shown below, the installation of the panels would proceed from left to right.

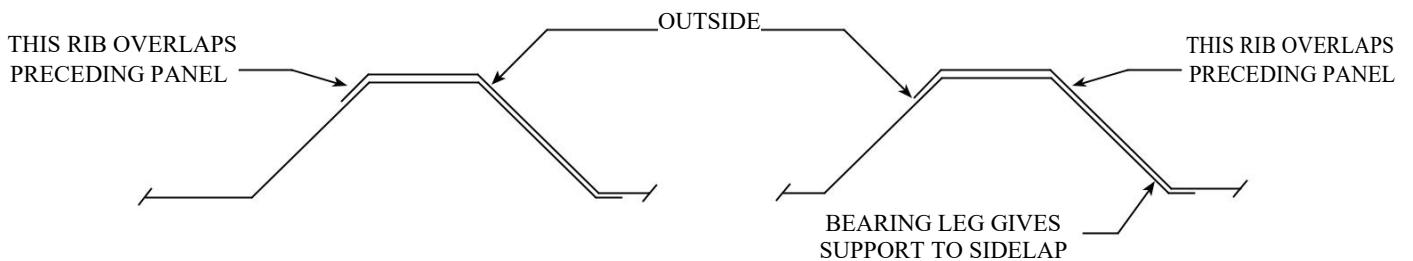
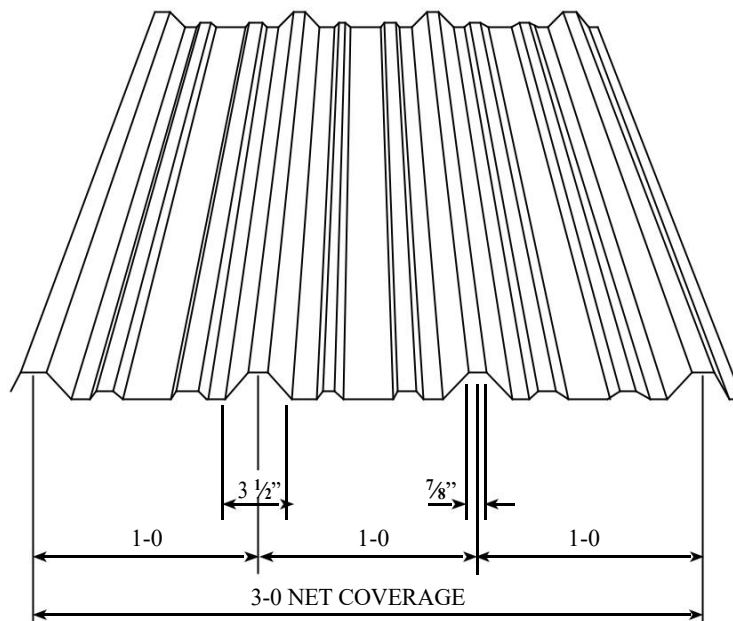

DANGER! Do not step on the major ribs, the side edge or end edge of the “PBR” panel.

SECTION 4

FASTENER INSTALLATION

Correct fastener installation is one of the most critical steps when installing roof panels. Drive the fastener in until it is tight and the washer is firmly seated. Do not overdrive fasteners. A slight extrusion of neoprene around the washer is a good visual tightness check.

Always use the proper tool to install fasteners. A fastener driver (screw gun) with an **RPM of 1700-2000 should be used for self-drilling screws.** A **500-600 RPM fastener driver** should be used for self-taping screws. Discard worn sockets; these can cause the fastener to wobble during installation.

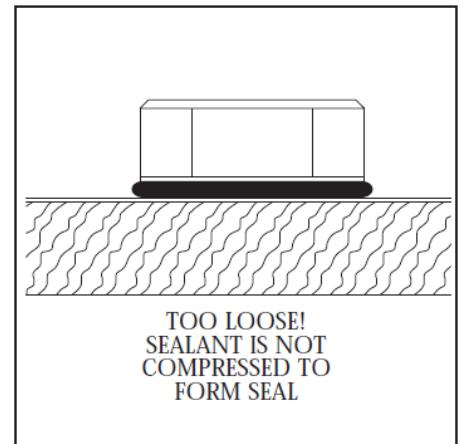
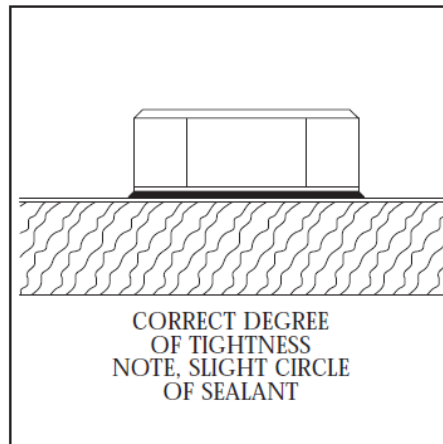
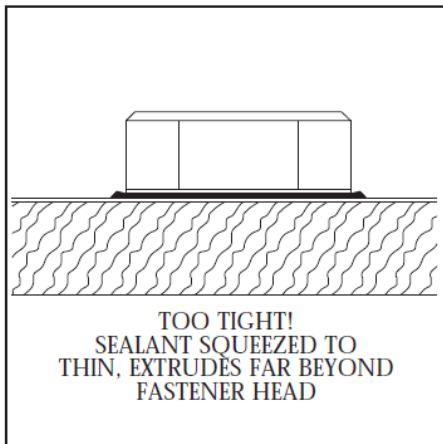

NOTE! Always remove metal filings from surface of panels at the end of each work period. Rusted filings can destroy the paint finish and void any warranty.

FASTENERS AND ATTACHMENT DETAIL

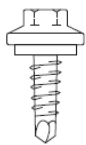

#12 SELF DRILLING CARBON STEEL 'LAP'

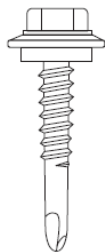

#14X7/8" SELF DRILLING CARBON STEEL 'TEK'

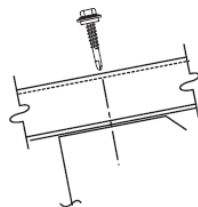

PANEL TO STRUCTURE

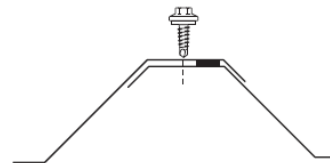

PANEL TO PANEL

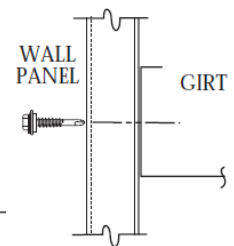

PANEL TO STRUCTURE

SECTION 4

FASTENER LAYOUT

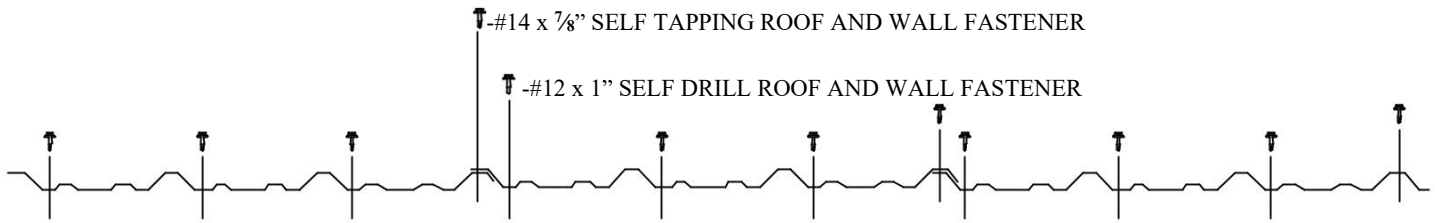

"PBR" ROOF AND WALL PANEL FASTENER SPACING
INTERMEDIATE PURLINS AND GIRTS

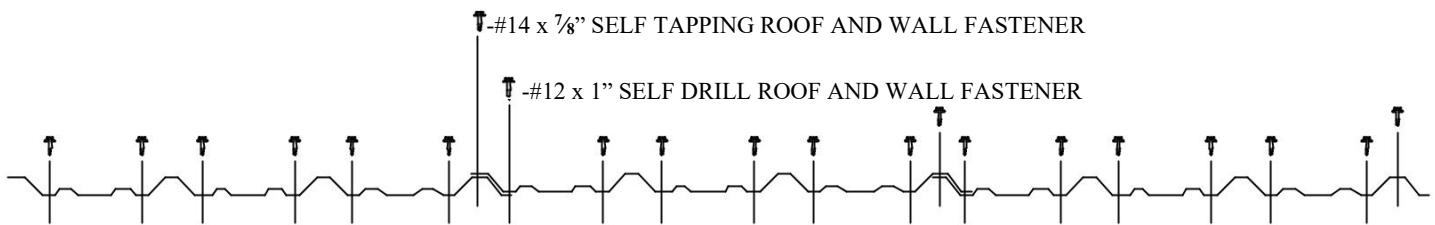

STOP!!! NOTICE FOR RIDGE AND EAVE ONLY!

"R" ROOF AND WALL PANEL FASTENER SPACING
EAVE STRUT, ROOF PANEL, END LAPS AND RIDGE PURLIN
TOP OF WALL SHEET AND BASE OF WALL SHEET

FASTENER PLACEMENT

ROOF: #12 x 1" Tek screw, 6 inch on-center spacing at eave and ridge.
#12 x 1" Tek screw, 12 inch on-center throughout remainder.

WALL: #12 x 1" Tek screw, 6 inch on-center spacing at base of panel and top of panel.
#12 x 1" Tek screw, 12 inch on-center throughout remainder.

LAP SCREWS (STITCH SCREWS): #14 x 7/8" lap, 24" on-center maximum on roof and wall panel laps.

NOTE! Do not overdrive fasteners.

WALL SCREW ALIGNMENT

Good alignment of the screws on the wall panels, will give a professional appearance to the wall panel installation. One way this can be accomplished is by predrilling holes in the panels at identical locations. Up to **10 panels** can be stacked together and drilled using a template panel. Use $\frac{1}{8}$ " or $\frac{5}{32}$ " **diameter** drill bit for panel to structural fasteners and a $\frac{1}{4}$ " diameter bit for the side-lap clearance holes. It is important to clean metal filings off panel after drilling to avoid rust stains.

NOTE:



(EXAMPLE SHOWN IS FOR SHEETING FROM LEFT TO RIGHT)

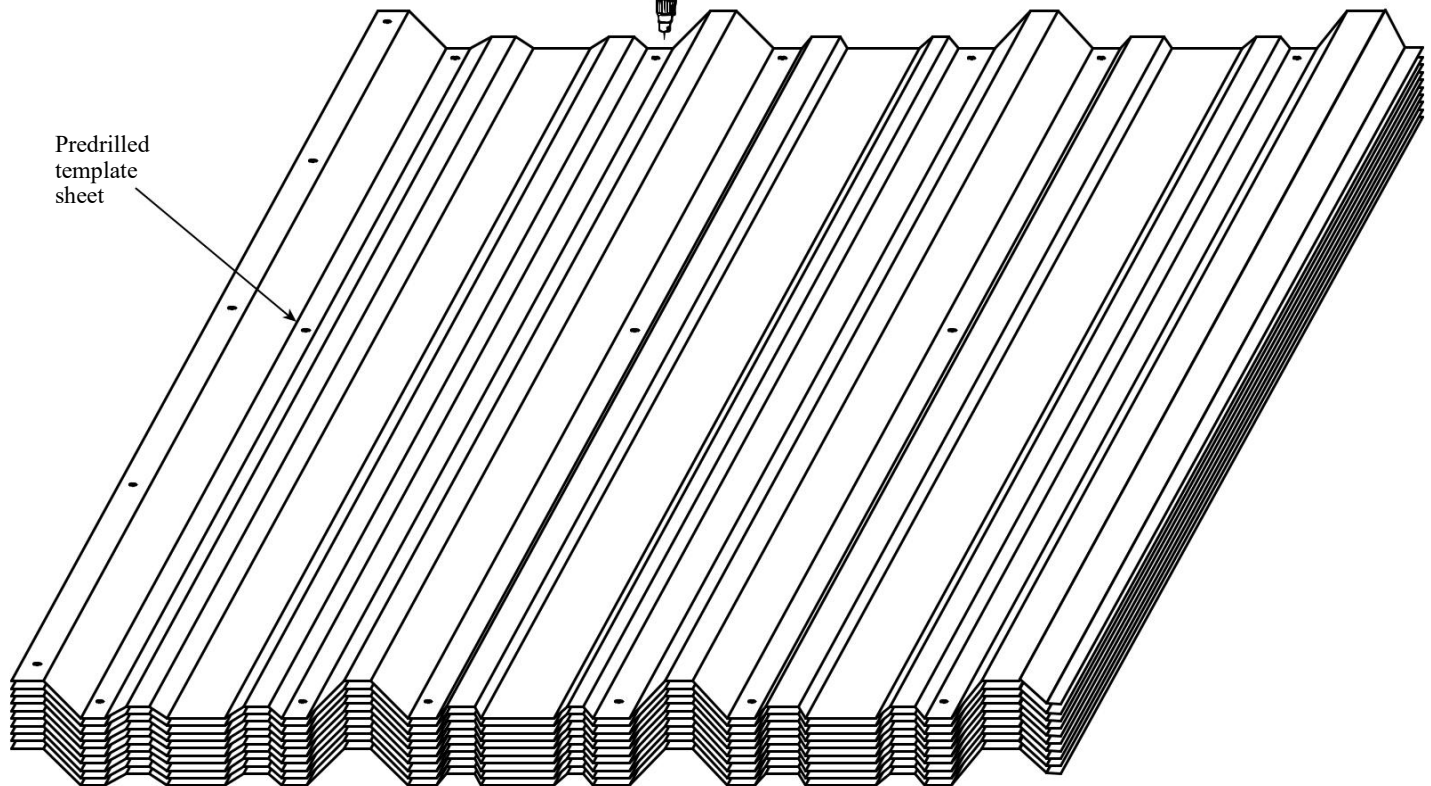

Stacked sheets to be drilled.

WE HIGHLY RECOMMEND PRE-DRILLING WALL PANELS

NOTE! Use OSHA approved eye protection when operating a drill. Electrical tools must be properly grounded. Do not use electrical tools or equipment while standing on wet surfaces.

SECTION 4

SCREW ALIGNMENT (CONT.)

The template panel should be laid out for the proper screw locations in accordance with the building erection drawings. Since pre-drilling will “hand” the panels, it will also be necessary to select the end of the building from which the paneling is to begin. Before drilling the template panel, it should be checked for proper hole locations against the building framework. Be sure there is not excessive deflection in the purlins and girts.

***Roof panels are *not* usually pre-drilled; however, we do recommend pre-drilling the lap rib of roof panels and lap rib of ridge caps for easier installation of lap screws.**

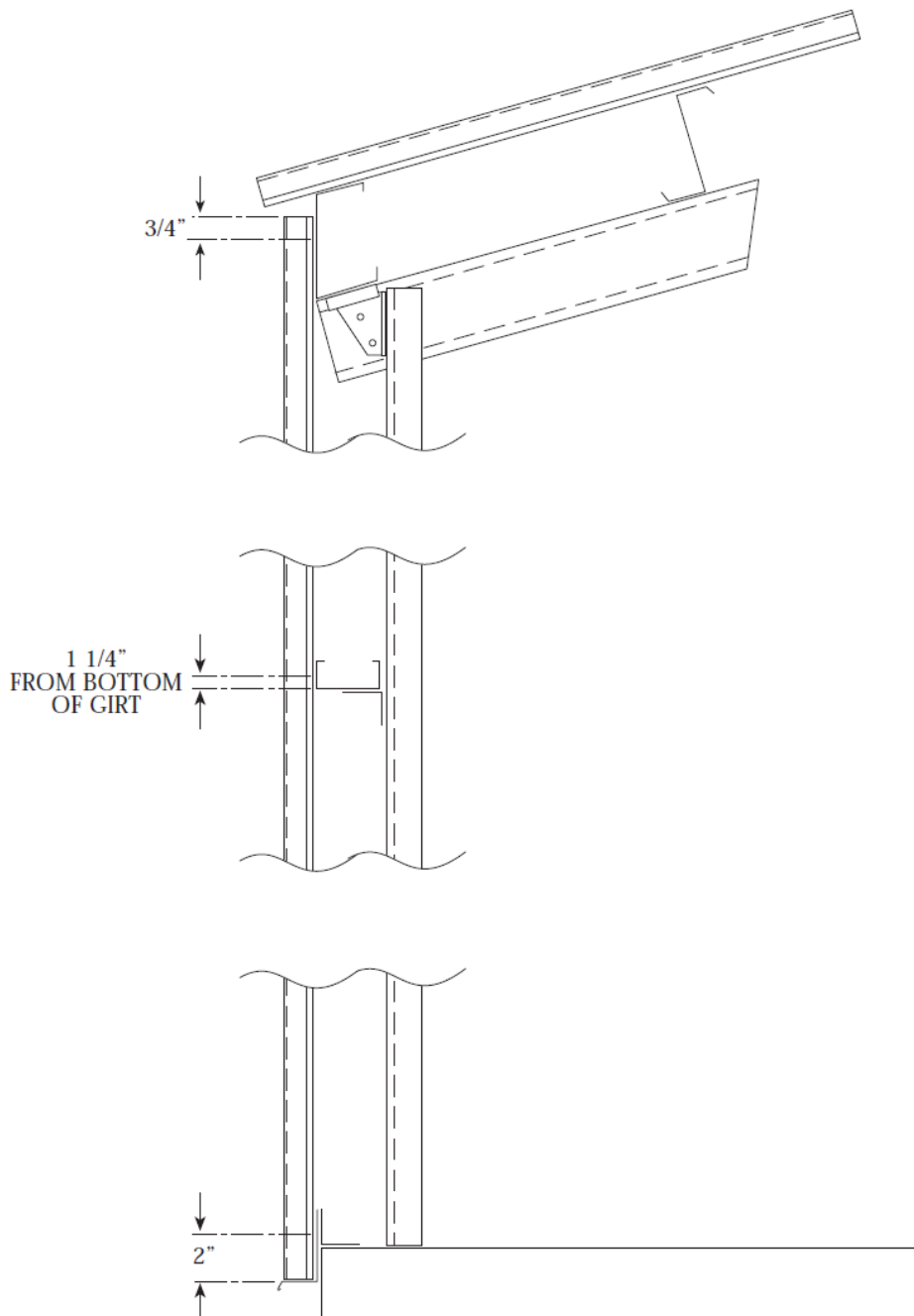

SECTION 4

ALIGNING THE GIRTS

Installation of the building walls is generally done before the roof. Before starting the wall installation, check to be sure that the eave strut and girts are straight and plumb.

One method of aligning the girts is to cut temporary wood blocking to the proper length and install between the lines of girts. This blocking can be moved from bay to bay which will reduce the number of pieces required. Normally, one line of blocking per bay will be sufficient. Banding can also be used to hold the girts straight and plumb.

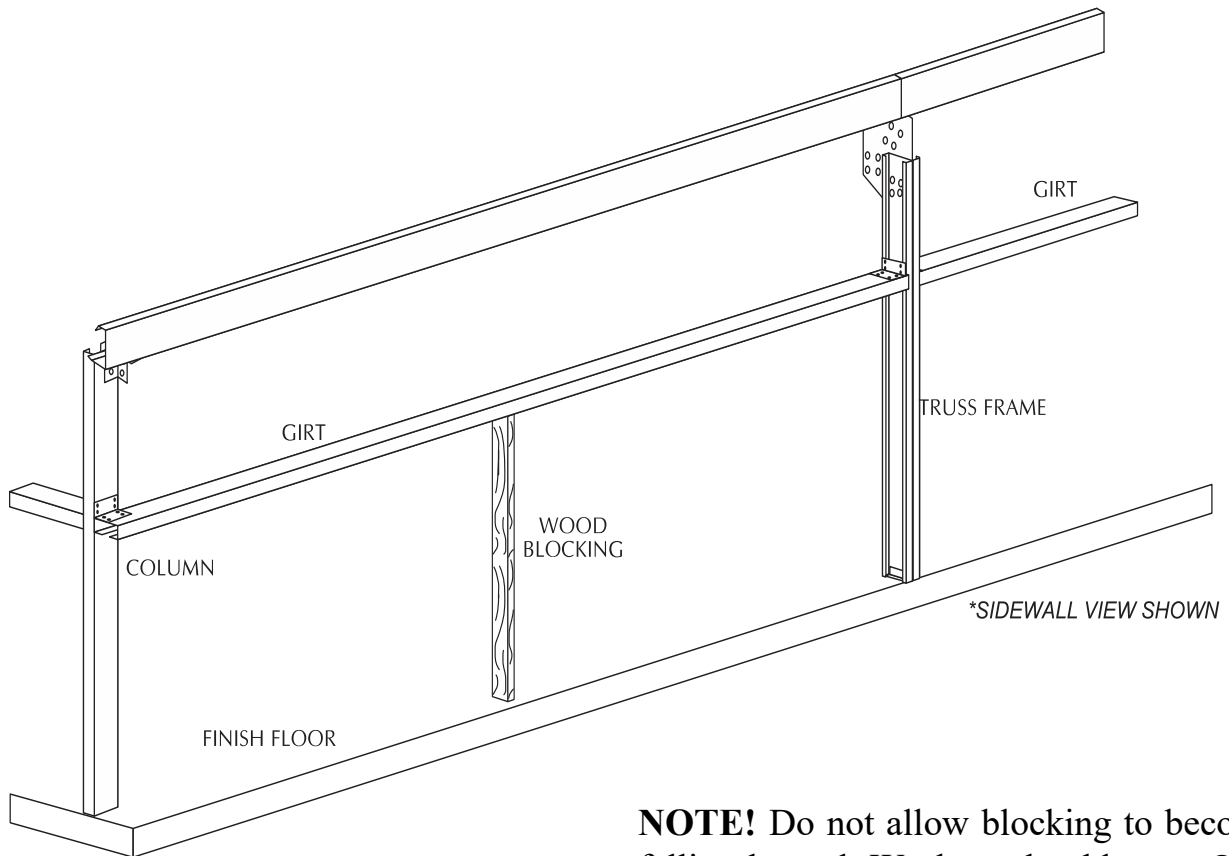

*TYPICAL GIRT SPACING

NOTE! Do not allow blocking to become a falling hazard. Workers should wear OSHA approved hard-hats. Girts should never be used as a climbing ladder. Damage to girt clips, as well as injury to workers may result.

SAFETY FIRST!

Typical construction of the wood blocking is shown above. A 2" x 4" minimum board size should be used. Refer to the sidewall framing drawing that accompanied the building to determine girt spacing.

WALL INSULATION

There are many types of insulation in pre-engineered steel buildings. However, fiberglass blanket insulation is the most common type used, and these instructions pertain to this type only.

One side of the blanket insulation should have a vapor barrier that must face the inside of the building regardless of whether the insulation is for heating or cooling.

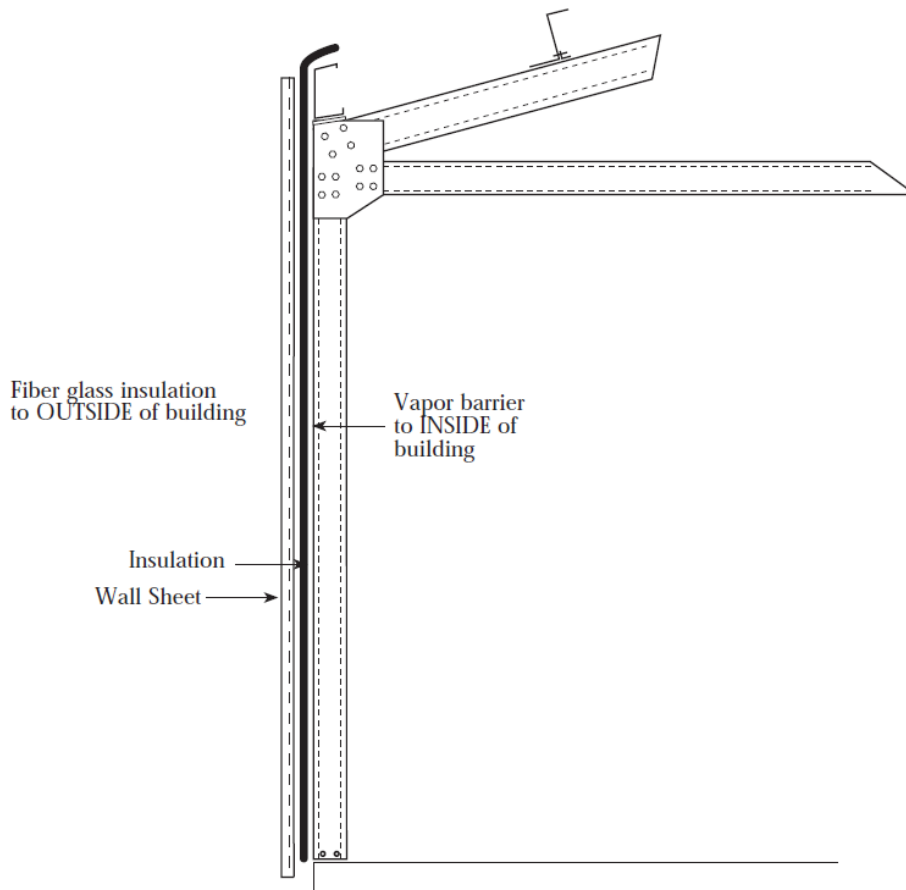

WALL INSULATION INSTALLATION

Cut the insulation to length allowing an additional 6" inches or more to facilitate handling. The wall panel can be used as a guide.

NOTE! The insulation must compress between the girt and the wall during installation. Insulation too thick or dense to compress adequately will induce waviness or oil canning in certain types of wall panels. *Insulation over 4" inches thick must be trimmed back at purlin and girt locations. If this is not done it will void the warranty of the panels.*

WALL INSULATION INSTALLATION (CONT.)

The first run of wall insulation should be installed so that its forward edge is just ahead of the leading edge of the wall panel. **The most widely used procedure is to use a 4' foot wide starter roll, then switch to a 3' or 6' foot wide roll.** This keeps the forward edge of the insulation 1' foot ahead of the wall panel for joining the next blanket.

**SAMPLE GIRT SPACING*

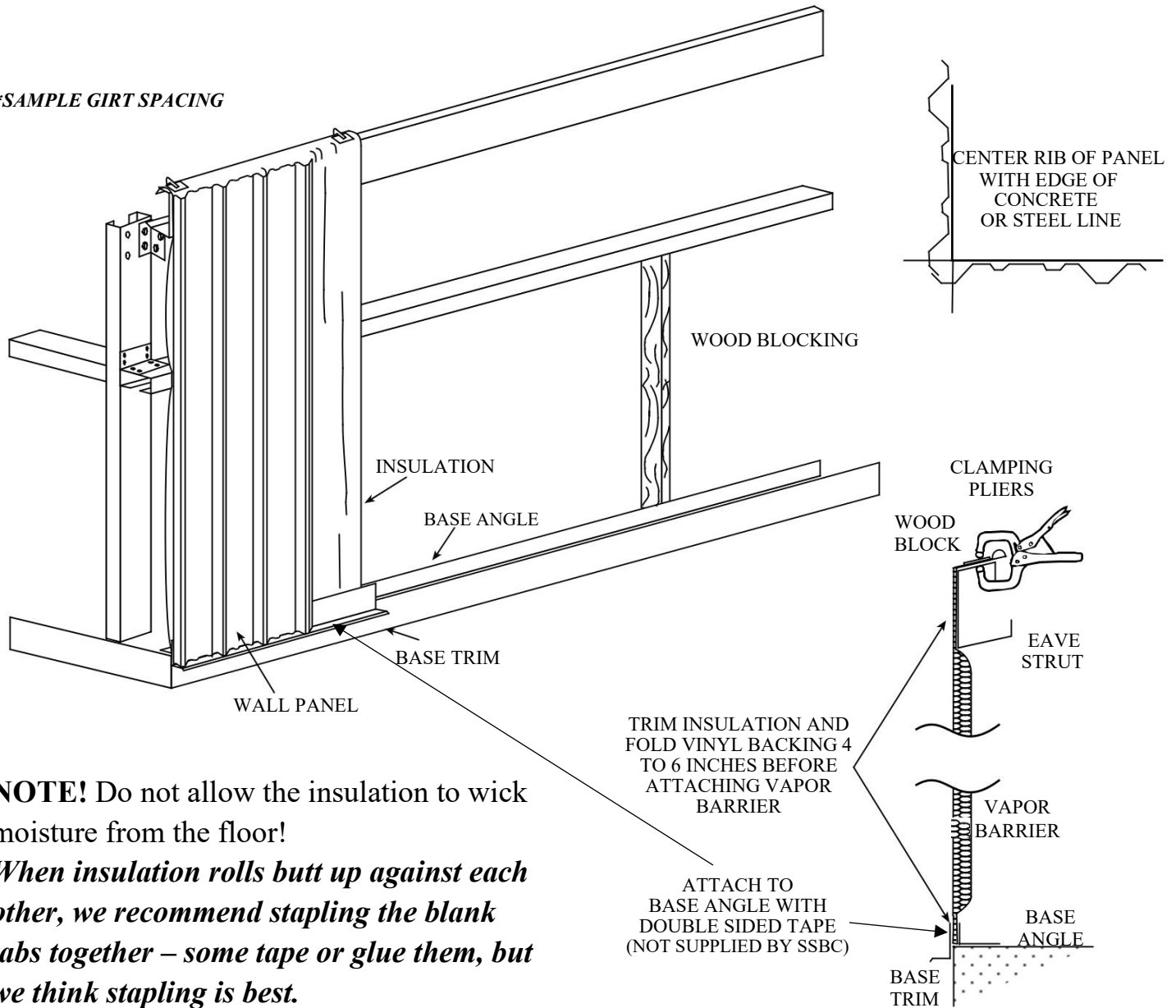

NOTE! Do not allow the insulation to wick moisture from the floor!

When insulation rolls butt up against each other, we recommend stapling the blank tabs together – some tape or glue them, but we think stapling is best.

NOTE! Insulation has no load bearing strength. Do not lean or prop material against wall insulation. Observe all proper safety procedures when handling fiberglass insulation, such as dust masks, gloves and long-sleeved shirts to minimize contact with the insulation fibers.

SECTION 4

INSTALLATION OF WALL PANELS

Adjoining panels are installed with the predrilled overlapping rib toward the last erected panel. Position panel to structure making sure that is kept plumb. Drill panel if required and install fasteners at lapped rib. Check for proper coverage and correct as necessary. Install remaining fasteners. Note that clearance holes in overlapping rib must be predrilled. Common practice is to predrill top (lap) panel and let self-drilling screw drill the underneath panel.

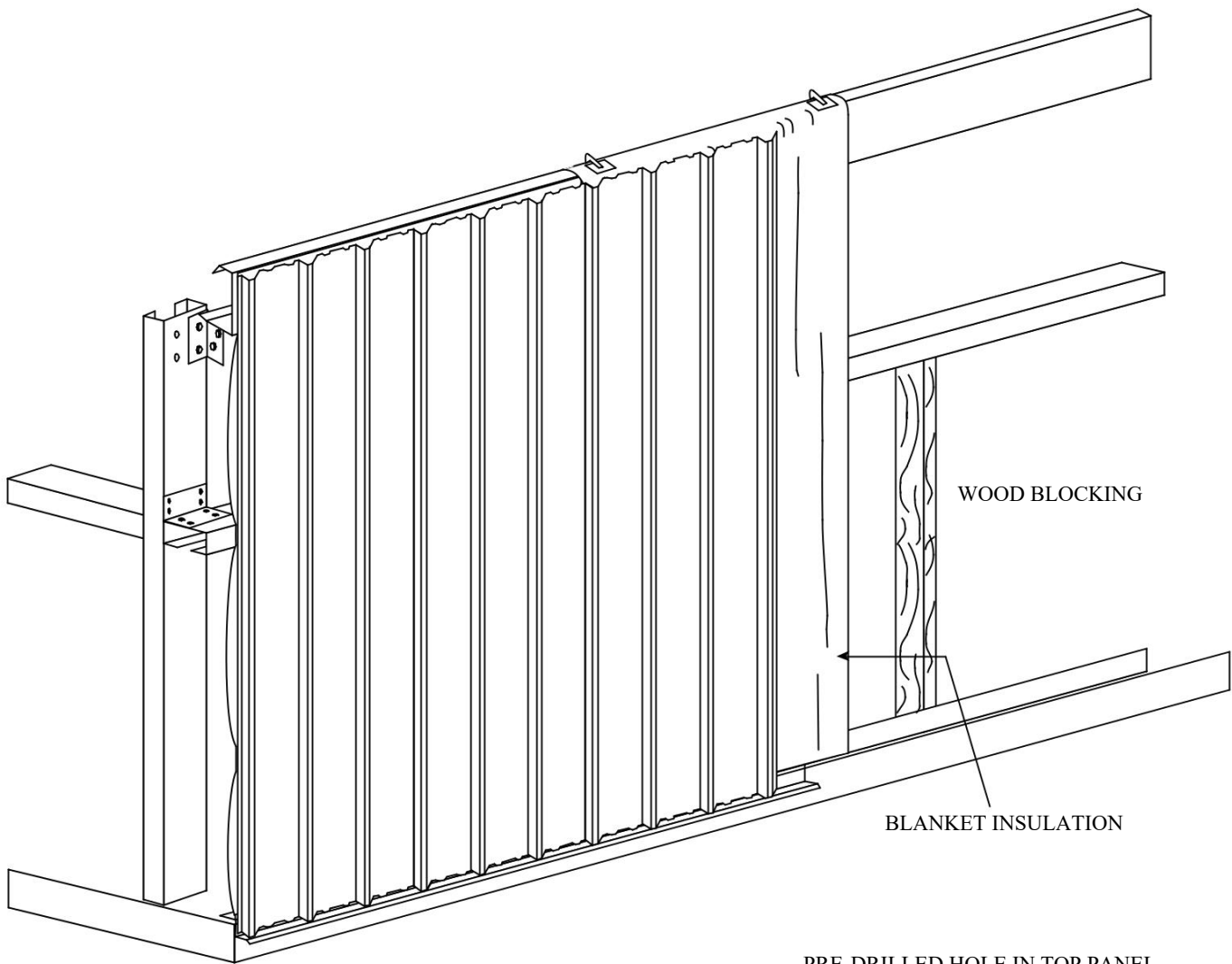

**TYPICAL GIRT SPACING*

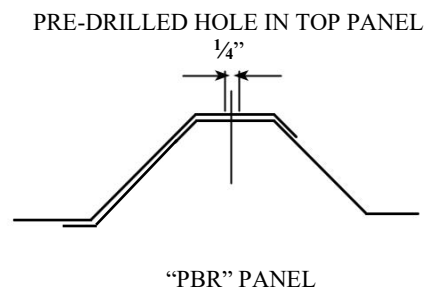

ROOF INSULATION

Pre-cut roof insulation to reach from eave to eave allowing approximately 2' feet of additional length to facilitate handling. Hold insulation at one sidewall and roll out insulation across the purlins, vapor barrier to the inside of the building. Stretch the insulation to provide a tight and smooth inside surface. Weights clamped to each end can be used to hold insulation taut.

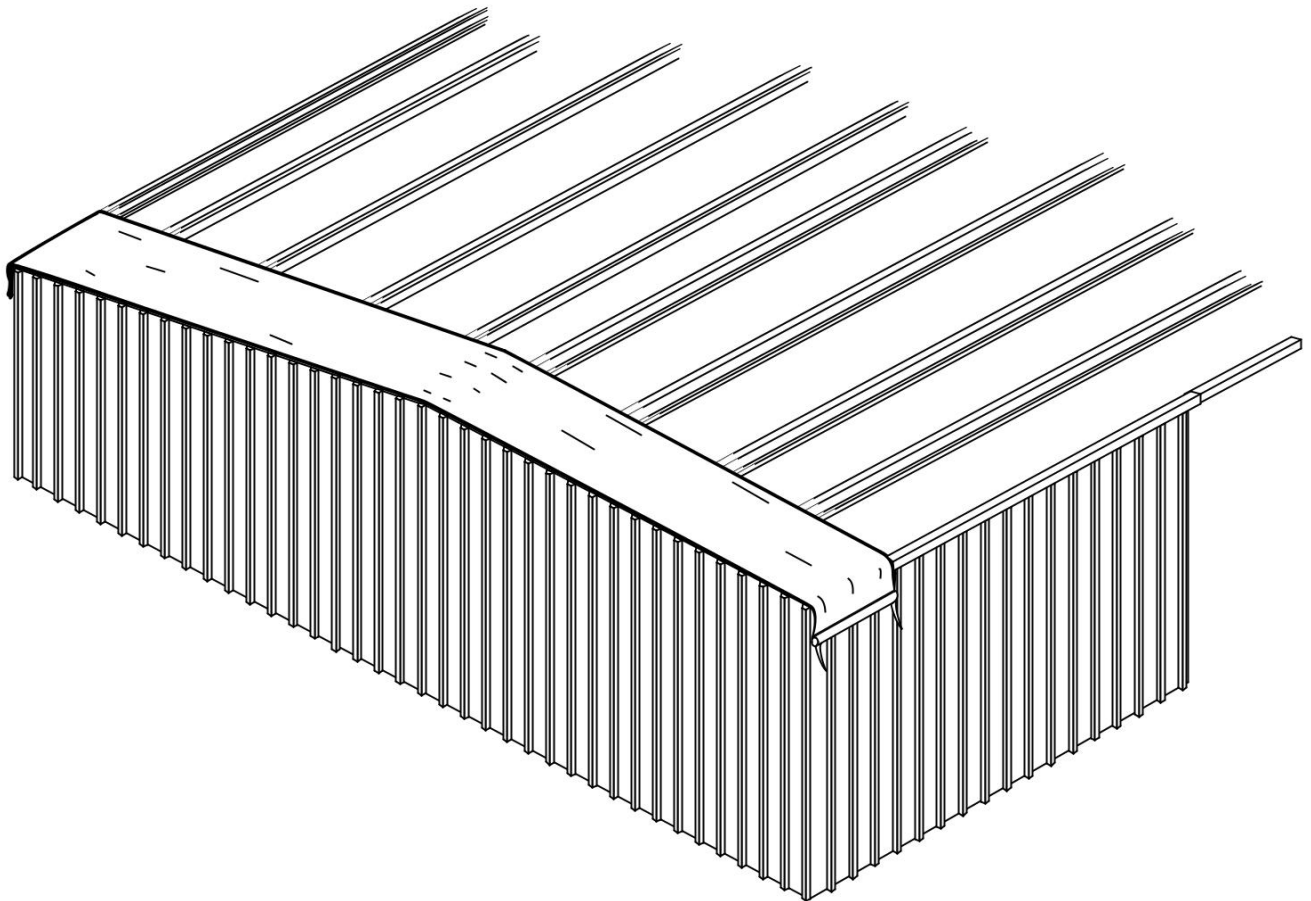

NOTE! Insulation has no load bearing strength. Maintain body weight on approved scaffold or walk boards. Follow all OSHA recommended safety instructions regarding safety harnesses and/or nets to protect from falls! **SAFETY FIRST!**

SECTION 4

ROOF INSULATION (CONT.)

Double sided tape or contact adhesives (not supplied by *SSBC*) can be used to hold insulation in place while the roof sheets are being installed. Trim excess insulation to the edge of the eave trim and cut fiberglass approximately 4" inches from end, leaving only facing. Fold facing over the end of blanket insulation to seal the ends.

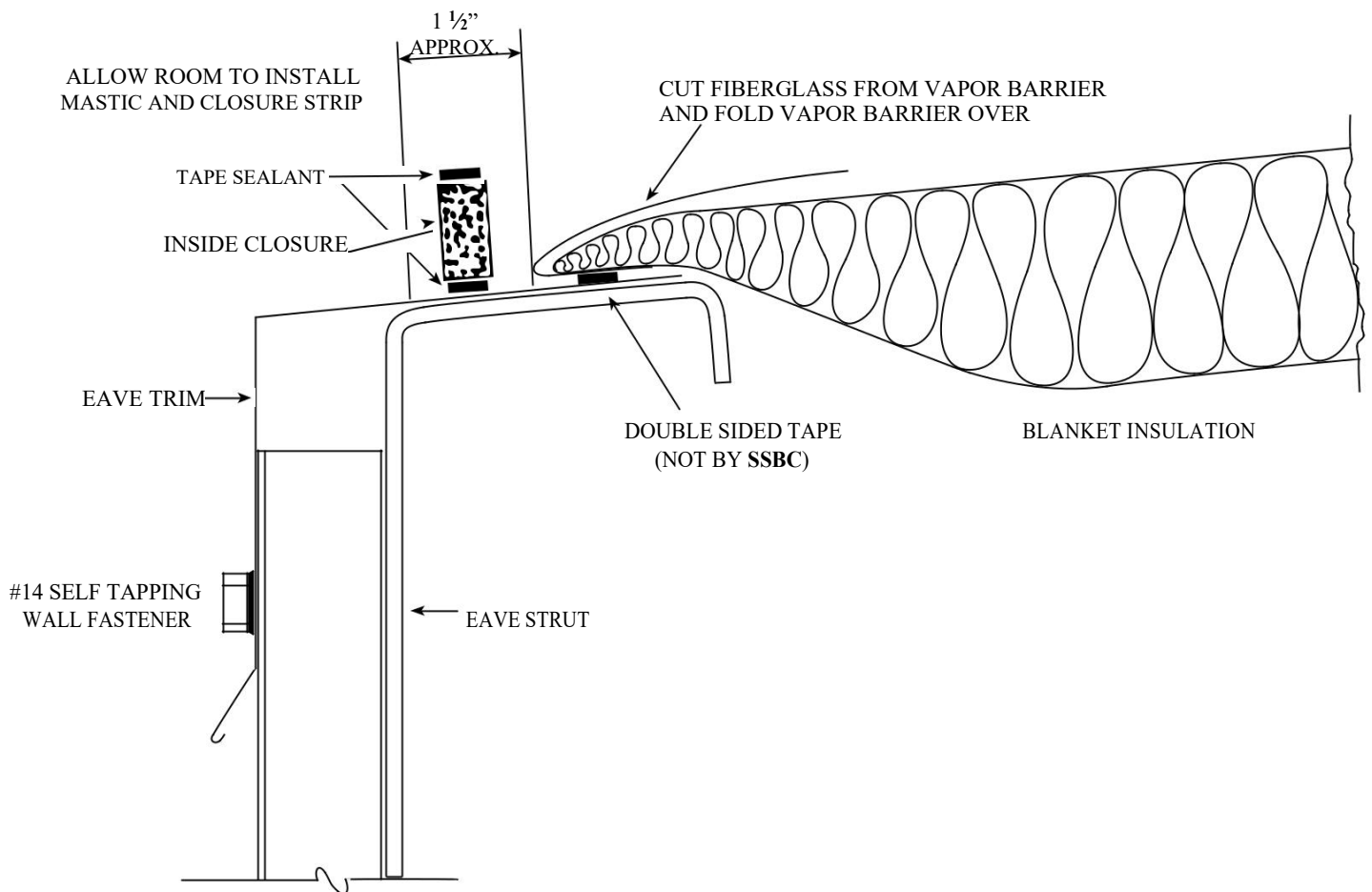

NOTE! Do not install more insulation on the roof than can be covered by roof panels before the work period ends. Do not allow the insulation to become wet. **SAFETY FIRST!**

SECTION 4

ROOF INSULATION (CONT.)

A 4' foot starter roll of insulation is recommended to maintain the insulation joint ahead of the sheeting edge. Seal insulation sidelap joints with adhesives or **fold and staple**. As on the walls, the general sequence is to install the roof sheets in conjunction with the insulation.

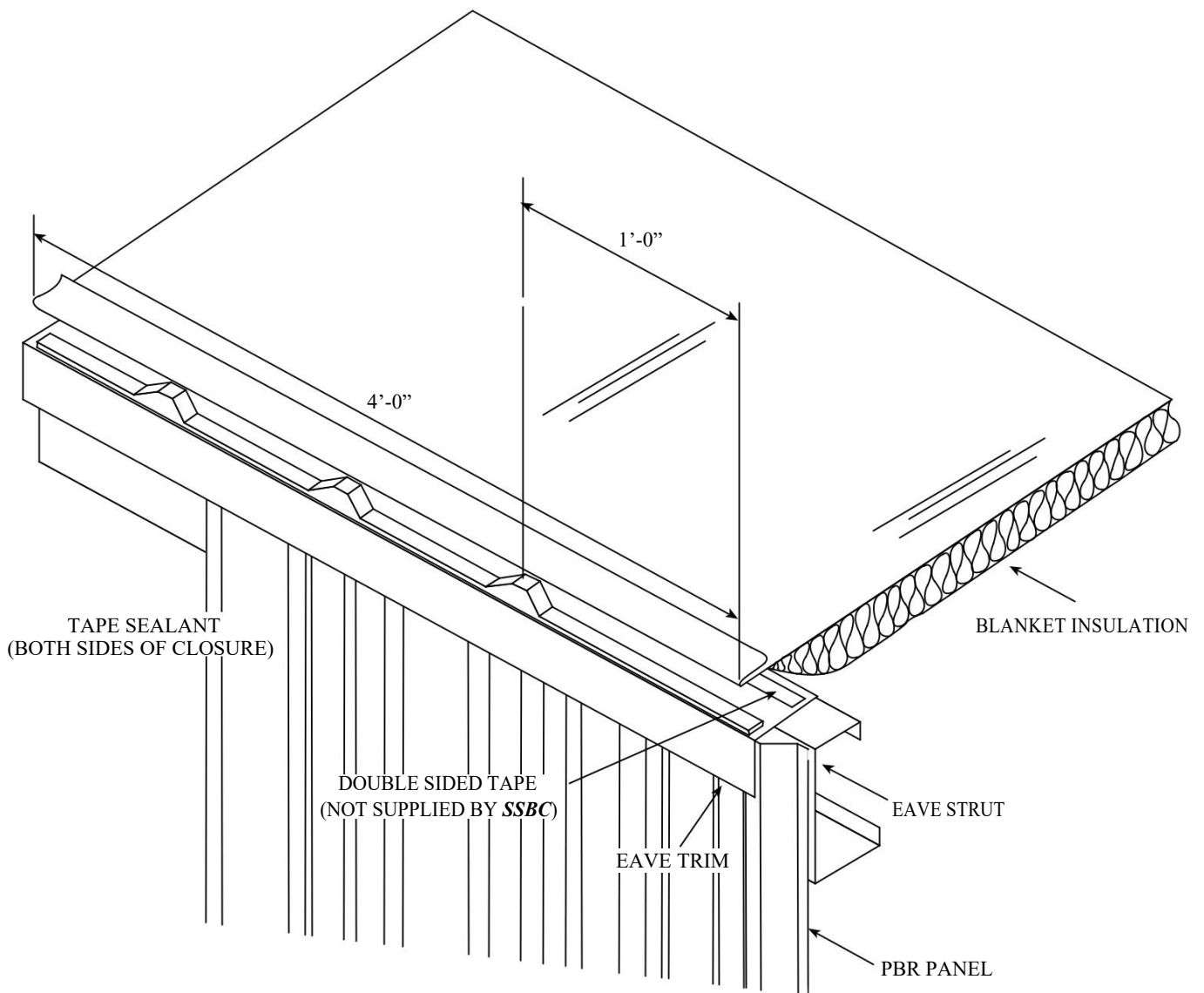

SAFETY PRECAUTIONS FOR ROOFING WORK

Simpson Steel Buildings strongly recommends that erection employees be continuously trained and retrained in safe and productive work practices. Working on the roof area in the installation of roof structural, insulation or roof panels requires proper training, correct equipment and constant alertness to minimize the danger of falls. Hard hats should be worn on job sites to prevent injury from falling objects. Safe work practices on all erection duties should be carefully reviewed with erection crews prior to beginning each job.

NEVER STEP ON SKYLIGHTS OR TRANSLUCENT PANELS!!!



PANELS MAY COLLAPSE IF NOT PROPERLY SECURED

Roof panels must be completely attached to the purlins and to panels on either side before they can be a safe walking surface. *Skylights or translucent panels must never be considered as a walking surface.*

PARTIALLY ATTACHED OR UNATTACHED PANELS SHOULD NEVER BE WALKED ON

DO NOT:

1. Step on rib at edge of panel
2. Step near crease in rib at edge of panel
3. Step within 5' feet of edge on unsecured panel

A single roof panel must never be used as a work platform. An OSHA approved runway should be used for work platforms! (Consult OSHA Safety and Health Regulations for the Construction Industry). **SAFETY FIRST!**

SECTION 4

SAFETY NOTE! CAUTION!! PANELS MAY BE SLICK

Because of the demands of the manufacturing process, oil has been applied to the coil stock to protect the coil, as well as the finished panel during manufacturing, shipping, and storage. Metal panels must be wiped clean **prior to panel installation.**

NOTE! Always wear rubber sole work boots! When on the roof use OSHA approved protection devices such as safety lines, safety nets or catch platforms.



UNSECURED PANELS MAY SLIP IF STEPPED ON!

Employees should be continuously warned never to step on a single unsecured roof panel, or a stack of roof panels laying unattached on the purlins.

Secure each end of the panel with clamps or appropriate fasteners and place walk boards of adequate size and strength in the flat of any panels not fully secured to the purlins and supported by panels on each side. Walk boards should run the full length of the panel and be fastened together by drilling a hole near the end of each board and tied with rope to the next board.

Cut a groove in the bottom of each board so that the board will lie flat and not tip back and forth because of the rope.

SECTION 4

PREPARING THE EAVE

After installing the first run of insulation, prepare the eave for the first roof panel by applying tape sealant along the eave outside of the insulation and leaving release paper in place. Sealant must be applied in a straight line and without voids. Do not stretch the sealant. Use a knife to cut if necessary. Cut an inside closure strip as shown and place starter piece on top of the sealant (removing protective paper from the sealant only as required). Align the major rib of the closure with the edge of the endwall roof line. Splice a full closure to the starting closure and apply along the top of the eave sealant. **If roof is subject to ice and snow buildup, the splice in the closure strip must be caulked to insure weathertightness.**

NOTE ABOUT INSTALLING EAVE TRIM: If your building has simple eave trim attach it to the eave strut using #12 x 1 $\frac{1}{4}$ Tek screws.

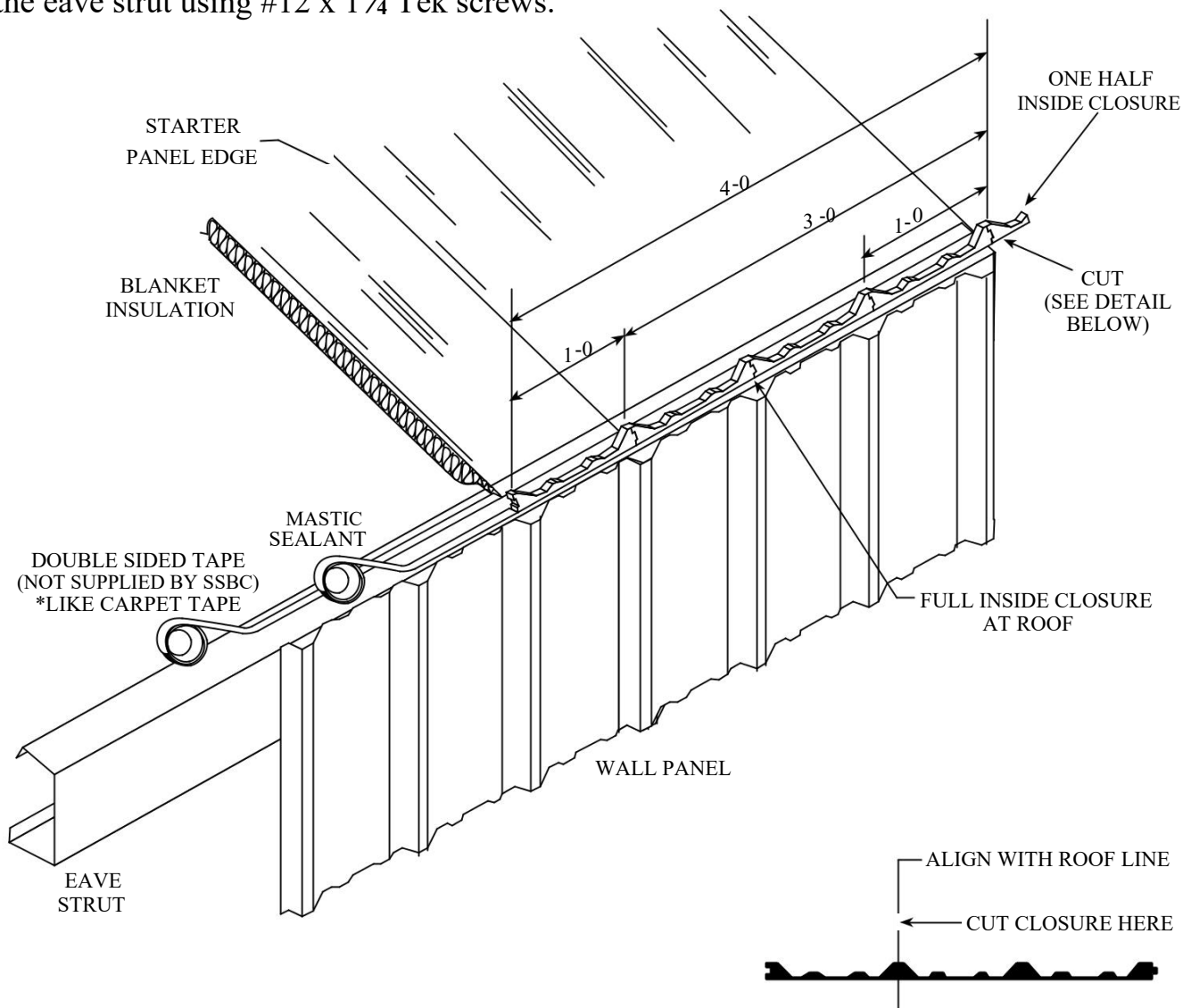

NOTE! Insulation has no load bearing strength. Maintain body weight on approved scaffolding or walk boards. **SAFETY FIRST!**

SECTION 4

PREPARING THE EAVE (CONT.)

Along the top of the closures that have been placed along the eave, *apply a second run of tape sealant*. Prior to removing paper backing, check and mark for proper alignment of the first roof panel. Note that self-tapping screws will require holes be drilled in the supporting structure prior to installation. Continue mastic and closure run along eave in preparation for the next roof panel.

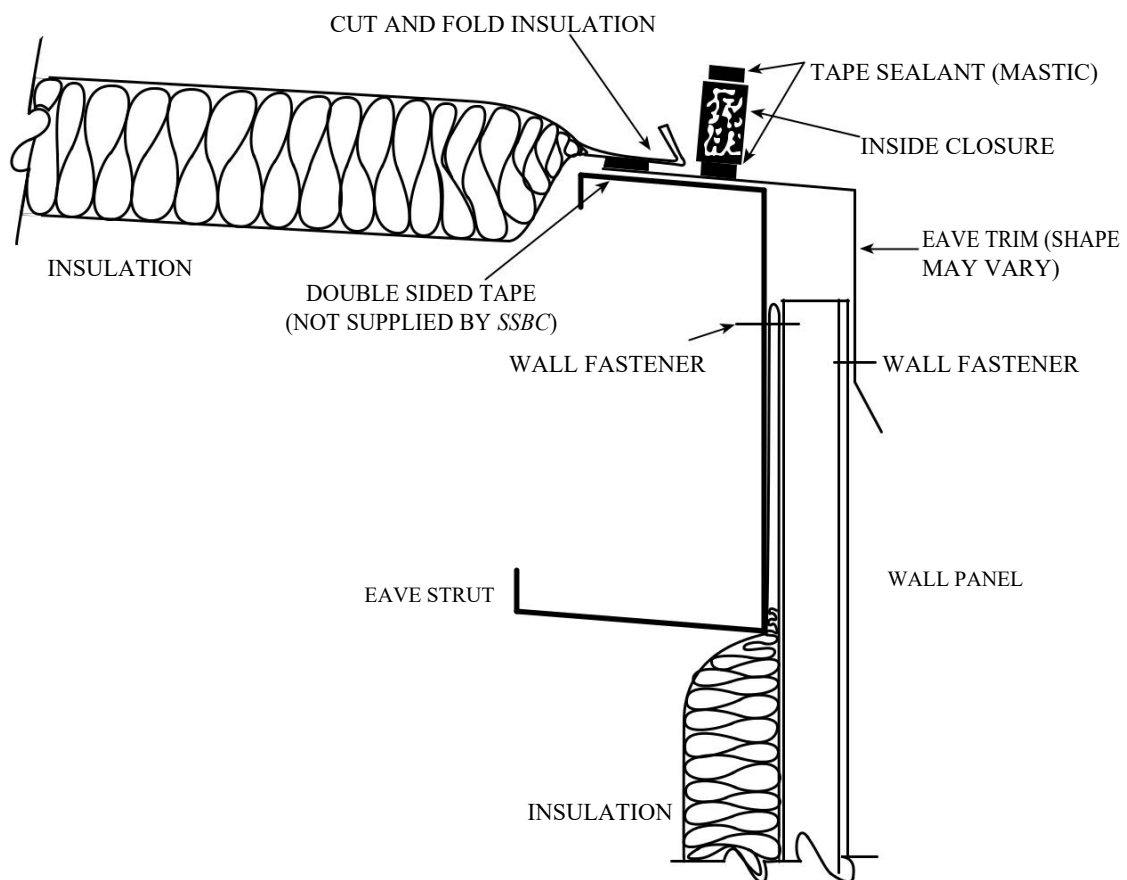

CAULK CLOSURE SPLICE WHEN ICE AND SNOW EAVE CONDITIONS MAY OCCUR

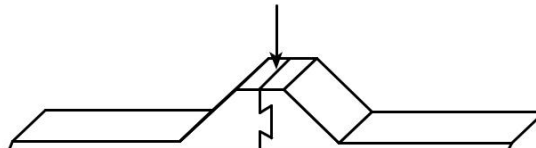

SECTION 4

INSTALLATION OF FIRST ROOF PANEL

Once the eave is prepared, the first roof panel may be installed. Set the roof panel in place over the inside closure (after removing the paper from the mastic) insuring the major ribs of the panel nest properly with the inside closure. **Extend the panel 3 ¾" past the eave strut or 2 ½" past the high rib on the wall panel.** With the panel properly placed, secure the panel to the structure with appropriate fasteners.

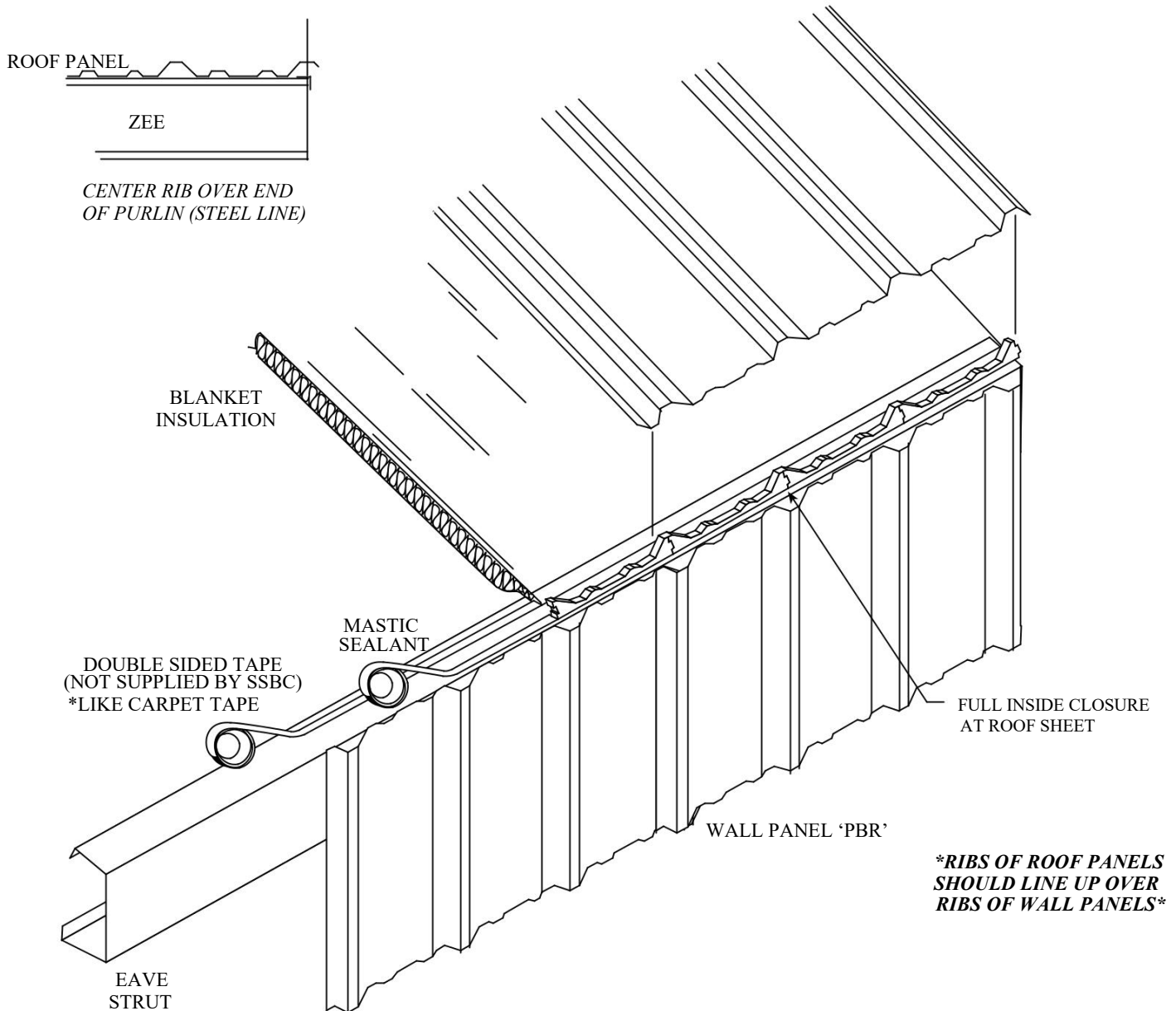

NOTE! Insulation has no load bearing strength. Maintain body weight on approved scaffolding or walk boards. **SAFETY FIRST!**

ROOF SHEETING SEQUENCE

It is recommended that both sides of the ridge of a building be sheeted simultaneously. This will keep the insulation covered for the maximum amount of time and the panel ribs can be kept in proper alignment for the ridge panel. Check for proper coverage as the sheeting progresses. Sheeting should progress in 3-foot increments.

Periodically measure to assure that you are not gaining or losing proper spacing. Ribs of roof should align over ribs of wall panels. If they do not line up with wall sheets, you are probably gaining or losing proper coverage spacing.

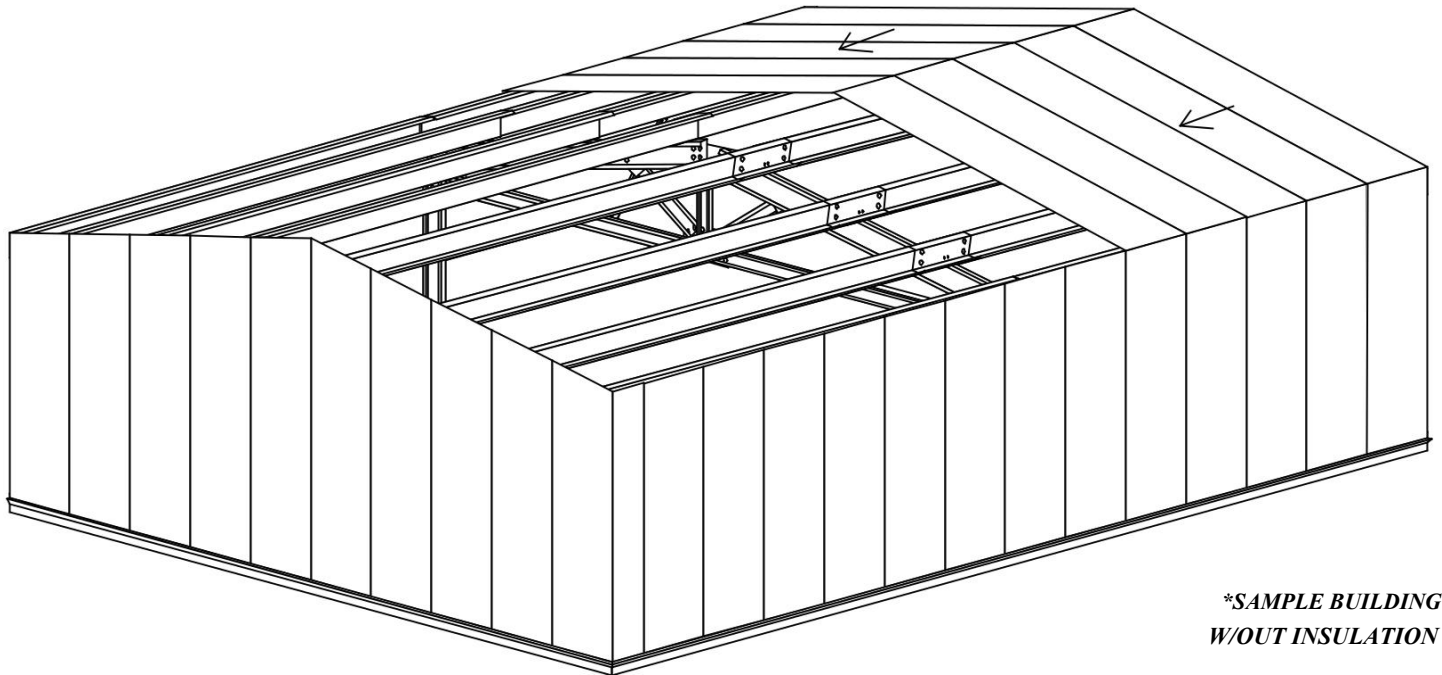

**SAMPLE BUILDING
W/OUT INSULATION*

NOTE! If oil or other slippery substances are present on the roof panels, wipe them clean immediately to prevent slipping or falling. Workers should maintain a constant awareness of their location relative to the roof edge. Use OSHA approved tie offs, nettings or rails when working on roof surfaces. **SAFETY FIRST!**

SECTION 4

INSTALLATION OF ROOF PANELS

With the first panel run installed and secured, and side lap sealant applied (see pages 60 and 61), the second panel run may be started. Prepare the eave with an inside closure and tape sealant as shown previously. Position the panel so that the overlapping ribs will nest properly. Be sure to check for proper overhang and panel coverage. Stitch the major ribs of the two panels together and fasten panel to the purlins.

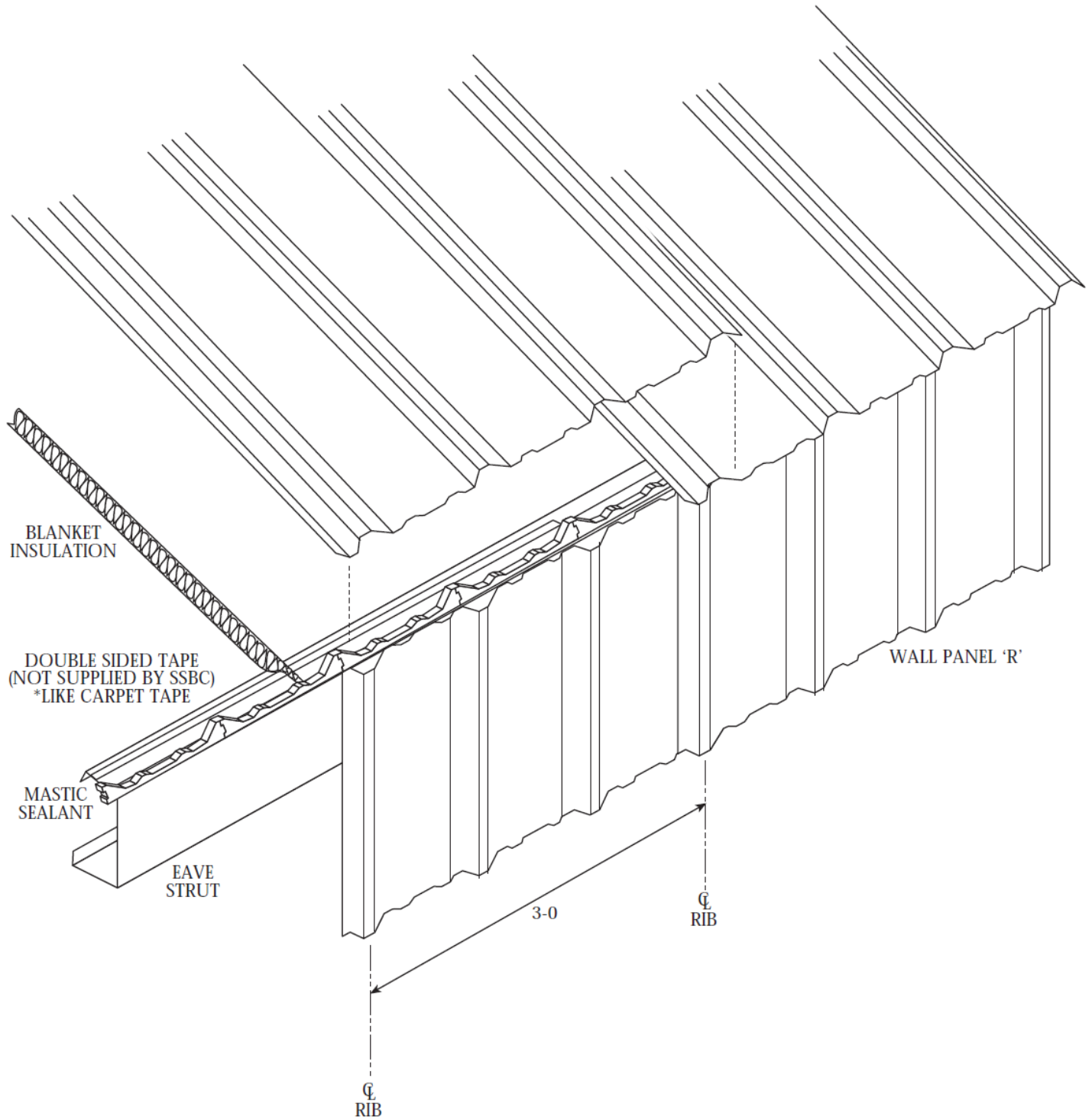

SECTION 4

SECTION AT EAVE (NO GUTTER)

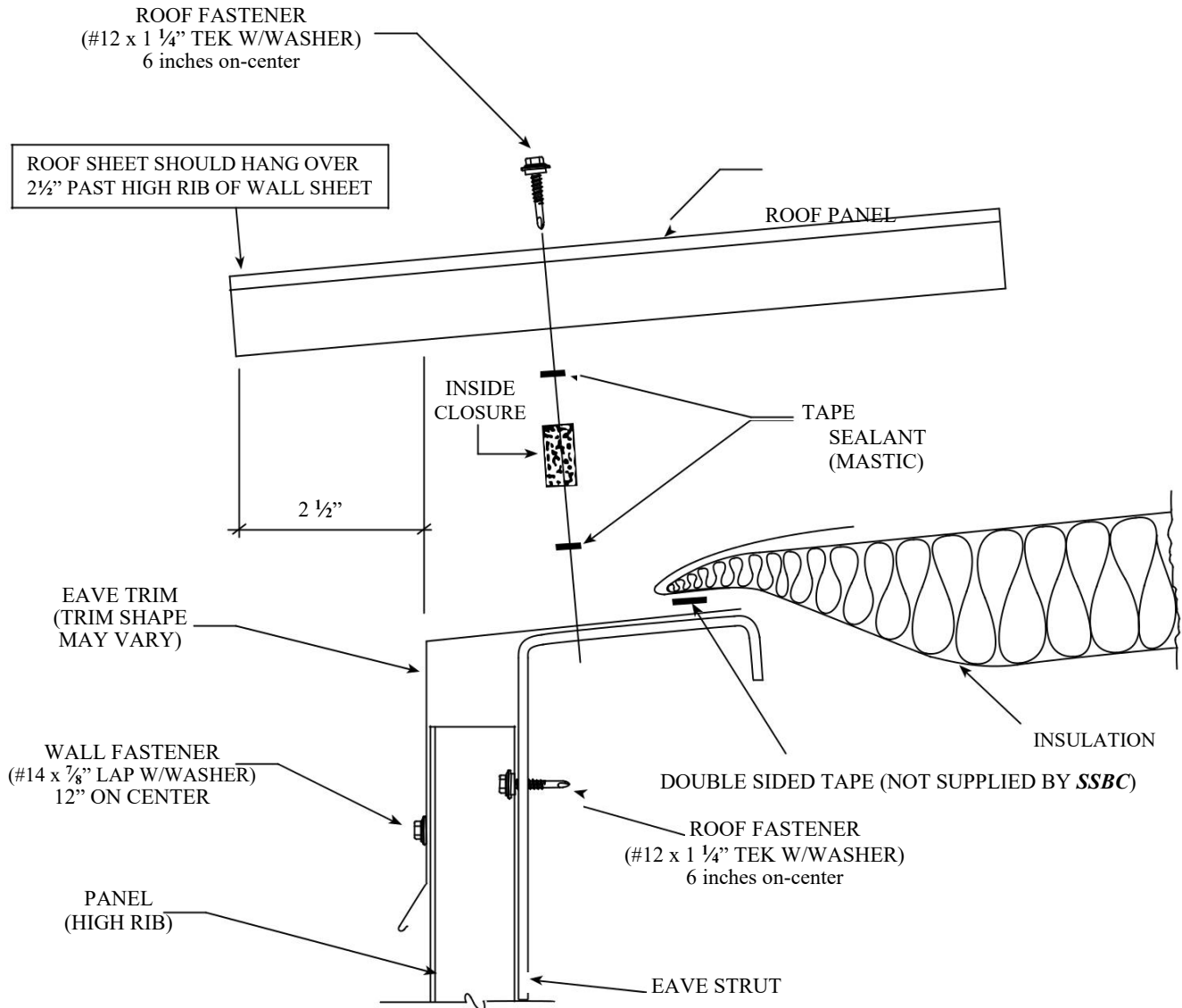

MASTIC SEALANT

Proper mastic application is critical or the weather tightness for the roof (only) of a building. Mastic should not be stretched when installed. Apply only to clean, dry surfaces. Keep only enough mastic on the roof that can be installed in a day. Store remaining mastic in a cool dry place. After mastic has been applied, keep protective paper in place until panel is ready to be installed. Mastic is 3/8" wide and comes in a 45' foot roll.

SECTION 4

SEALING THE ROOF PANEL SIDELAP

Apply the side lap tape sealant to the weather side edge of the lower panel's major rib as shown. The tape sealant should only be applied to clean, dry surfaces. With the release paper in place, press firmly along the length of the sealant to insure proper adhesion. In removing the protective paper from the tape sealant, care should be taken not to pull the tape sealant away from the panel. Install the adjoining panel, positioning the overlapping rib with care. Drill, at the center of the clearance holes in the overlapping panel, $\frac{1}{4}$ " clearance holes for the lap fasteners. Stitch the lap with the #14 self-drilling fasteners supplied with the job. **Never allow the sealant to be placed in other locations.**

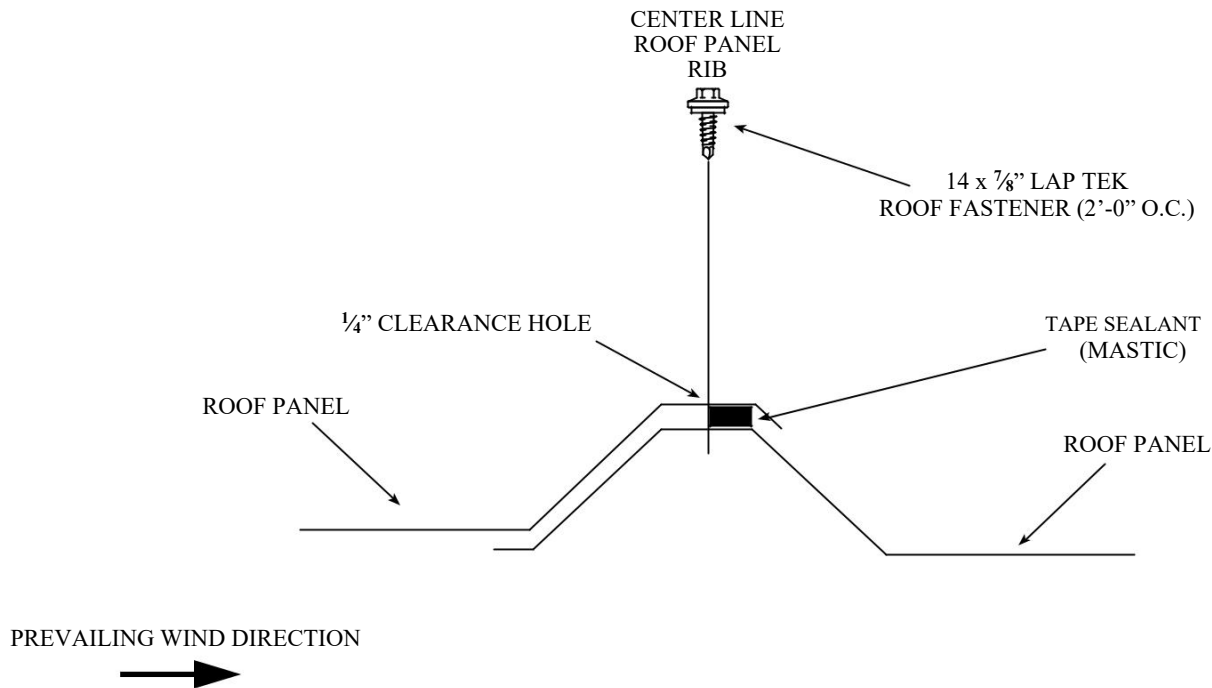

NOTE! Use OSHA approved eye protection when operating a drill. Sweep up all drill shavings from panels at end of each work period to minimize surface rust and damage to panel finish. **SAFETY FIRST!**

SEALING THE EAVE

Tape sealant location at the eave is critical. To ensure a weather tight seal, the side lap sealant must extend down from the top of the rib to the sealant on the eave closure. The sealant extension must splice into the eave mastic.

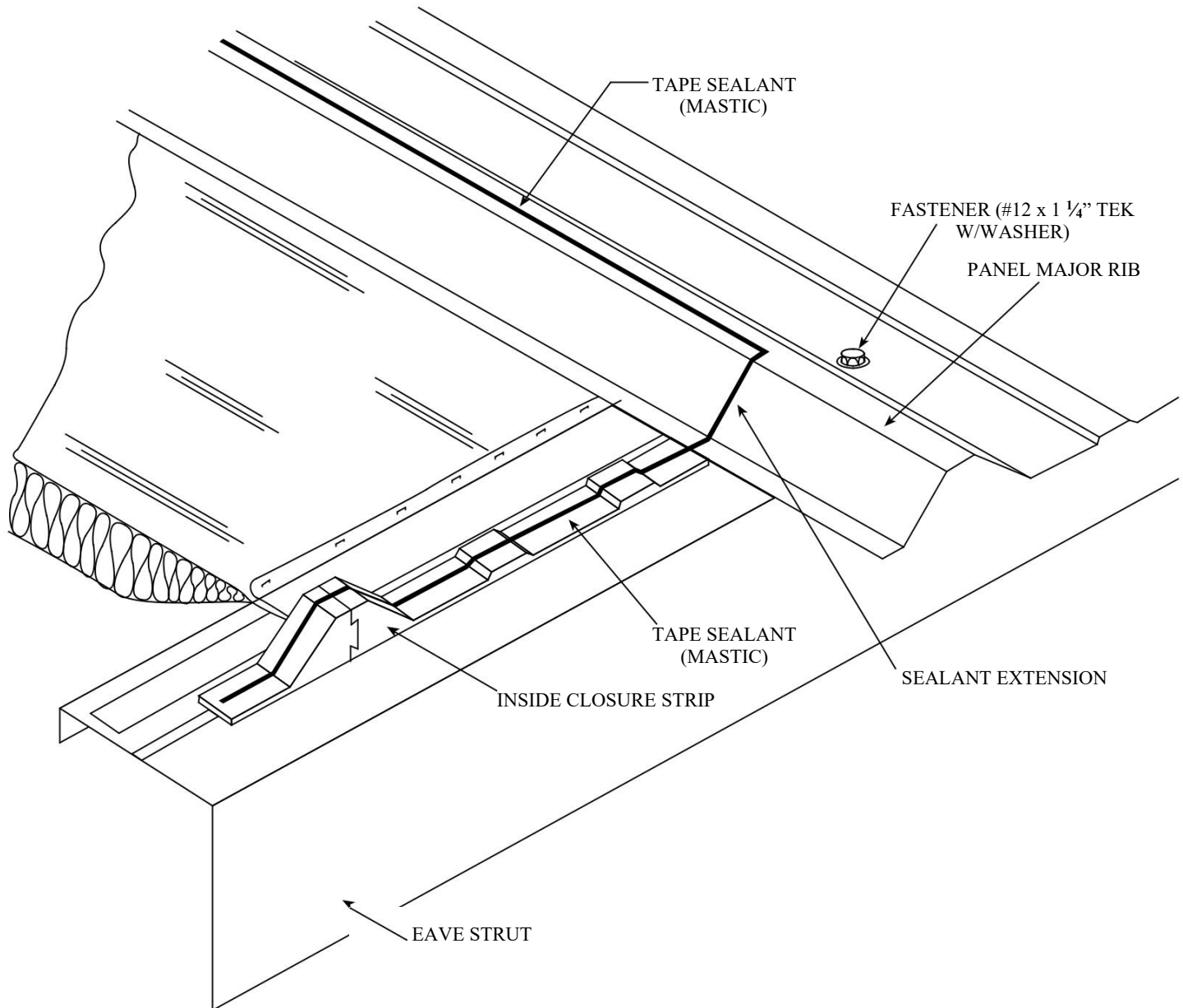

NOTE! Workers should maintain a constant awareness of their location in relation to the roof edge at all times. Follow all OSHA recommended safety suggestions. **SAFETY FIRST!**

DIE FORMED RIDGE INSTALLATION

Die formed ridge panels are to be installed as each side of the roof is sheeted. This will aid in keeping both sides of the roof aligned. After having installed a run of panels on each side of the roof, apply sealant to the panels as shown. Set die formed ridge panel in place and install lap purlin fasteners. Apply mastic tape sealant along the top of the leading rib to prepare for the next sideslip.

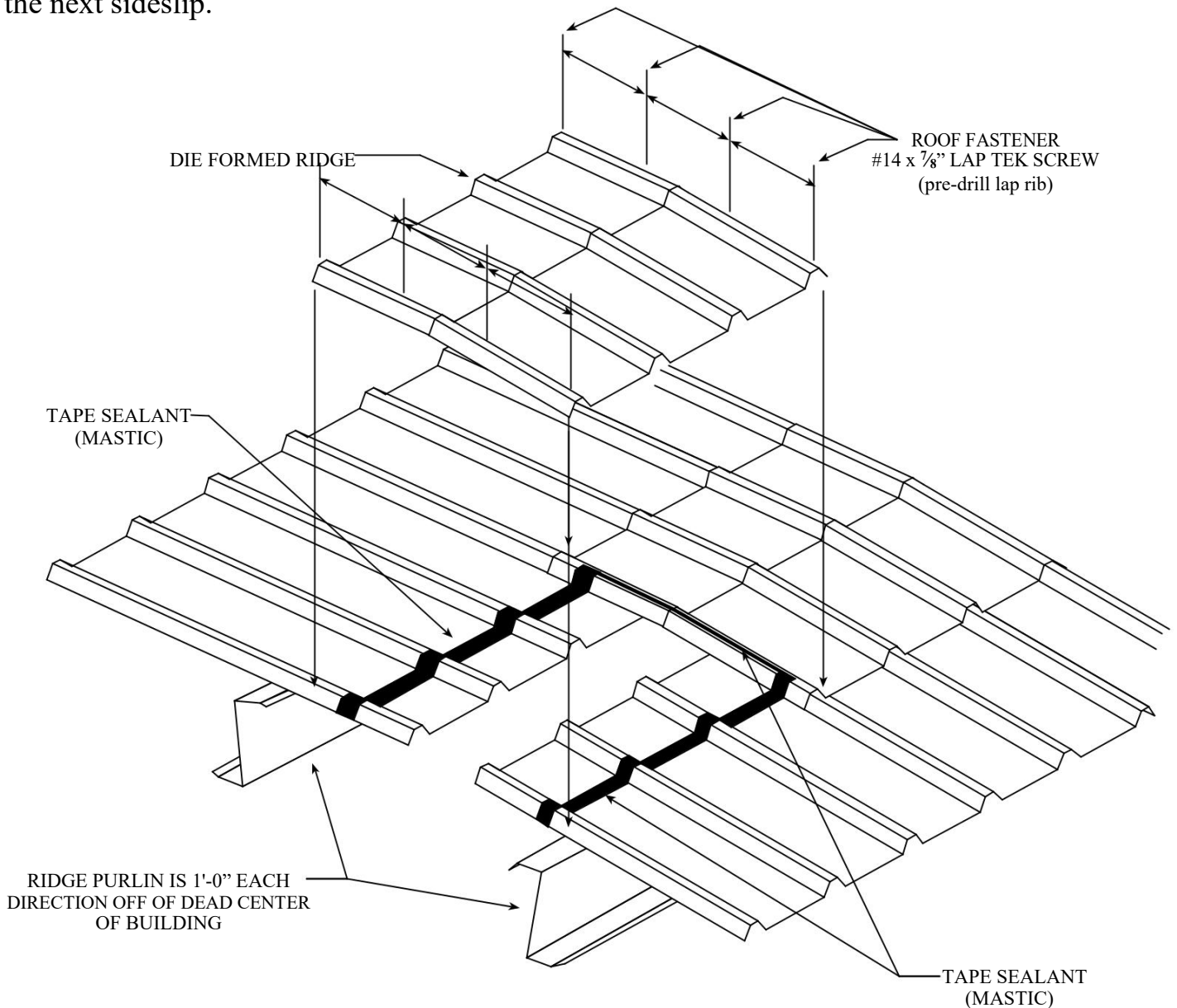

NOTE! Do not walk on unsecured ends of panels. **SAFETY FIRST!**

SECTION 4

INSTALLATION OF FINAL PANEL

While back-lapping the last roof panel (to match panel coverage with the building length) is routinely done, this installation method can compromise the integrity of the roof by trapping moisture between the panels. This moisture could, in time, create an environment conducive to rust and metal failure. **SSBC recommends field cutting the final panel lengthwise** to create the desired panel width necessary to finish off the building. The cut edge of the panel should always be installed on the outside edge, not the lap edge. The “narrow” panel should be handled with care, and foot traffic avoided until the final panel is completely installed.

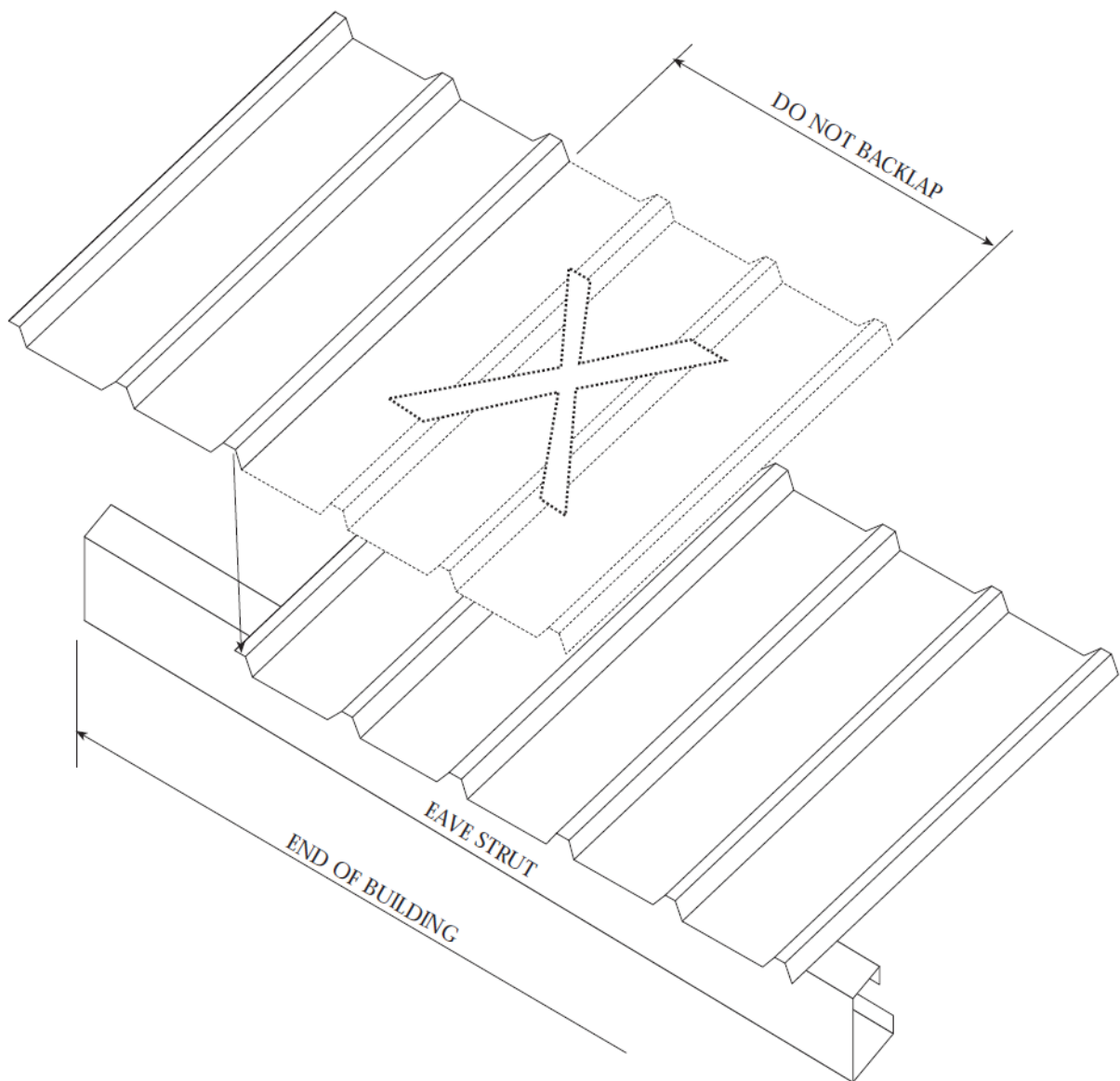

NOTE! SAFETY FIRST!

SECTION 4

SKYLIGHT INSTALLATION

Skylight panels are installed using the same procedures as a steel panel. Care should be taken when installing fasteners in the skylights to avoid cracking the material. Pre-drill $\frac{1}{4}$ " diameter fastener clearance holes in the overlapping side lap and end lap. Note installation sequence, 1 through 5.

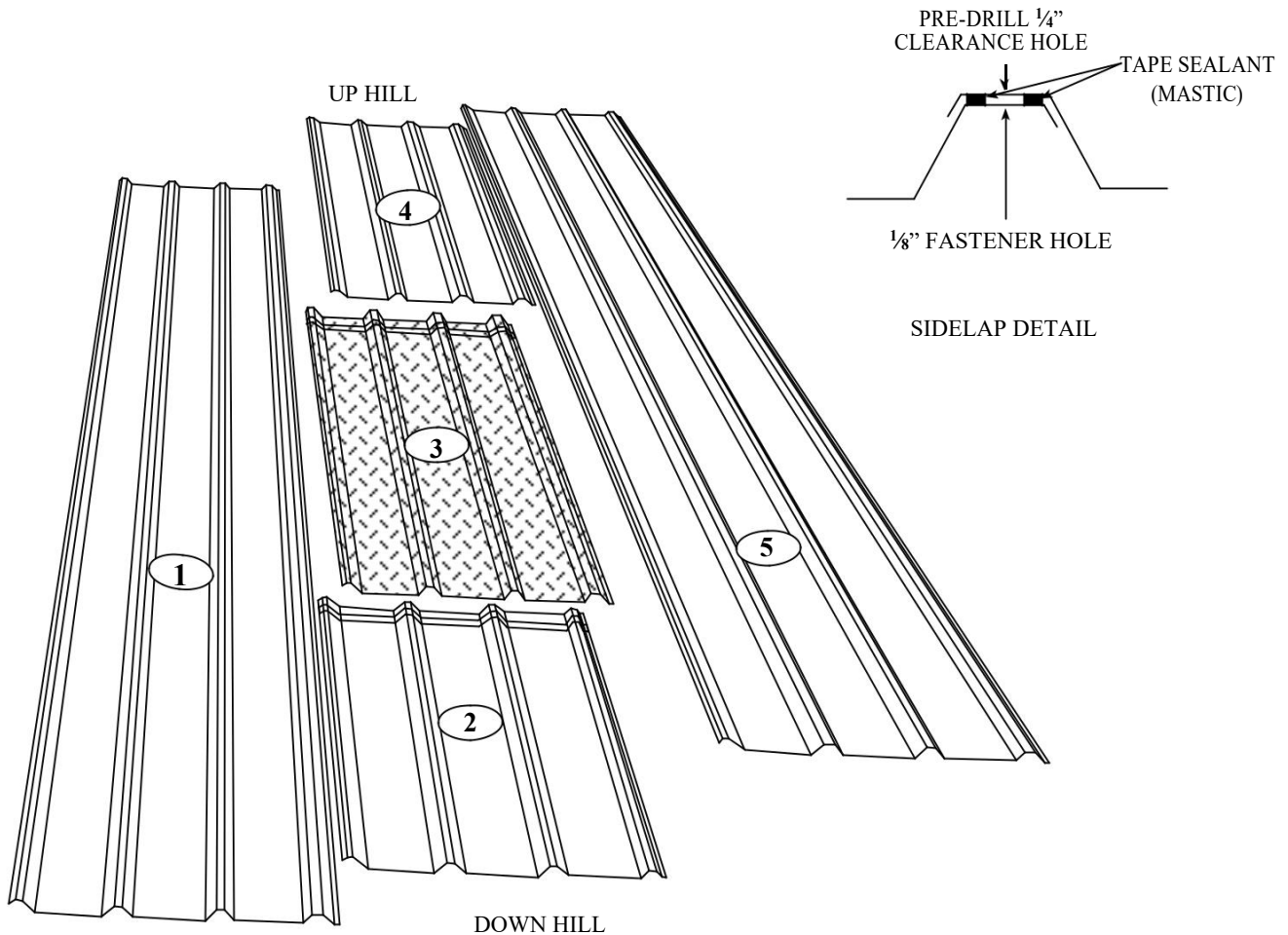

NOTE! - Do not under any circumstances step or walk on surface of skylight. If foot traffic is necessary over skylight, use walk boards that are properly supported by building purlins. Placing of "DANGER, DO NOT WALK" markings on every skylight must be done without fail. **SAFETY FIRST!**

SECTION 4

"PBR" PANEL TRANSLUCENT ROOF PANELS

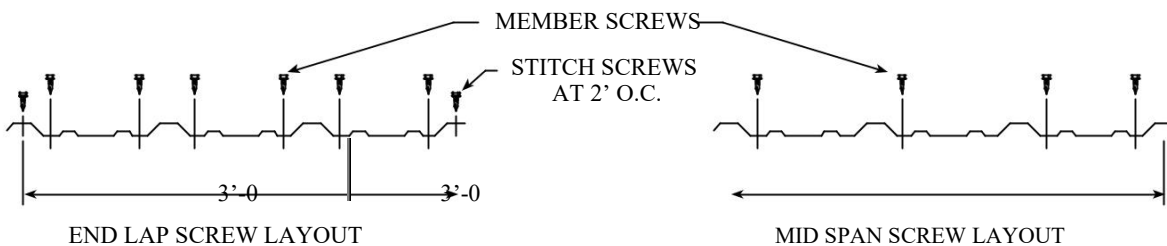
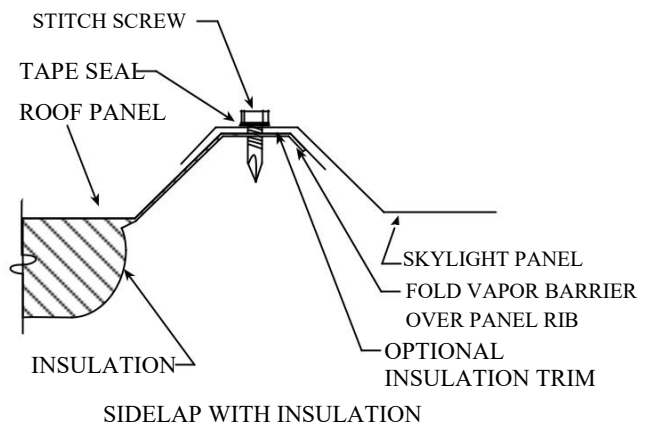
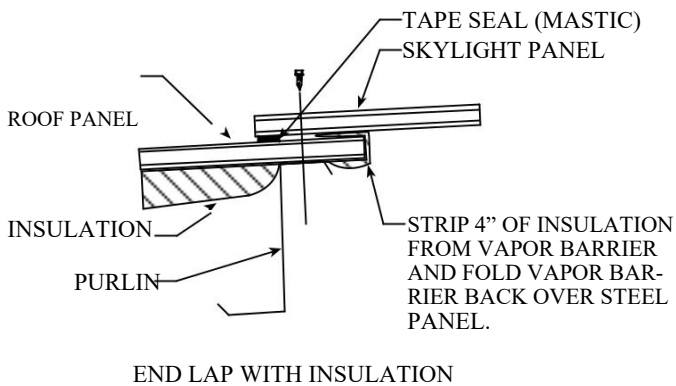
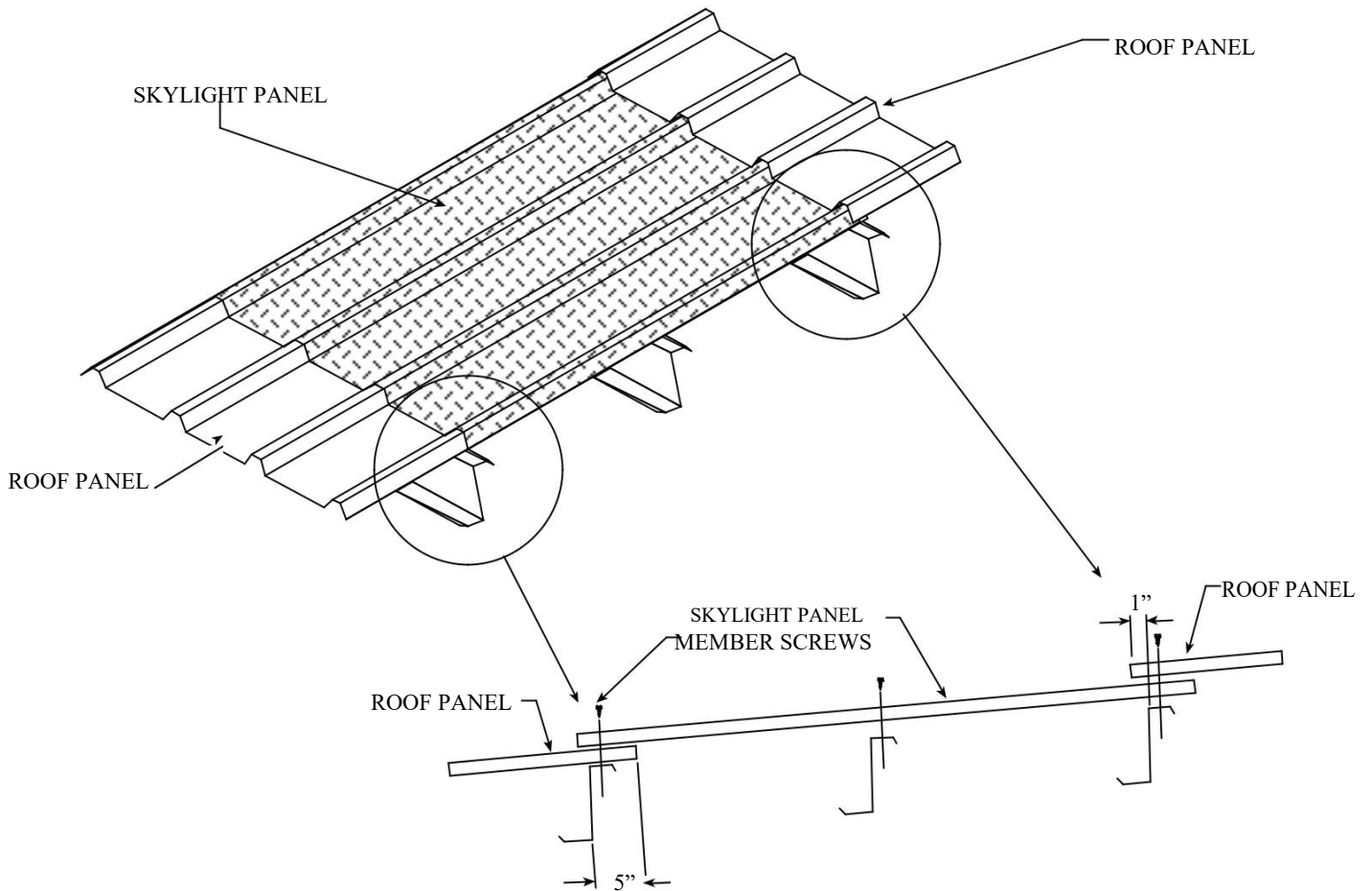

SECTION 4

INSULATED TRANSLUCENT PANEL AND UL-90 ASSEMBLY

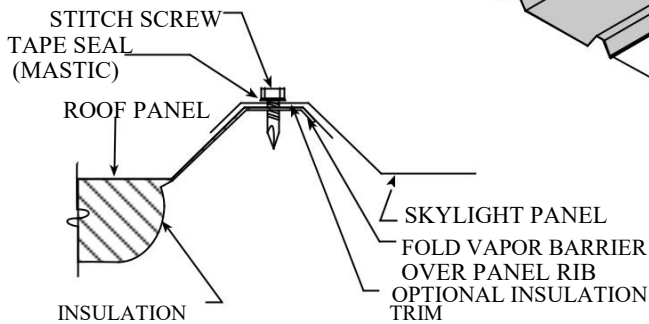
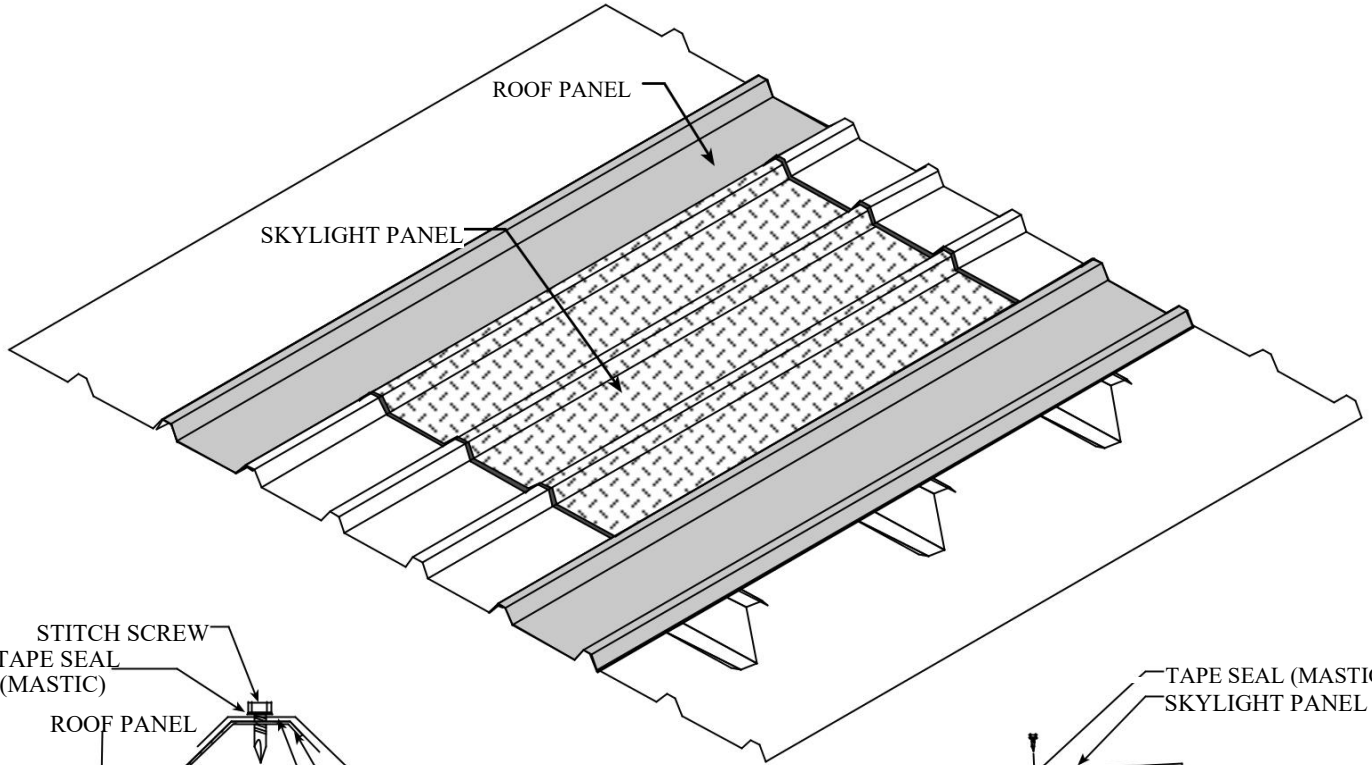

SECTION A-A

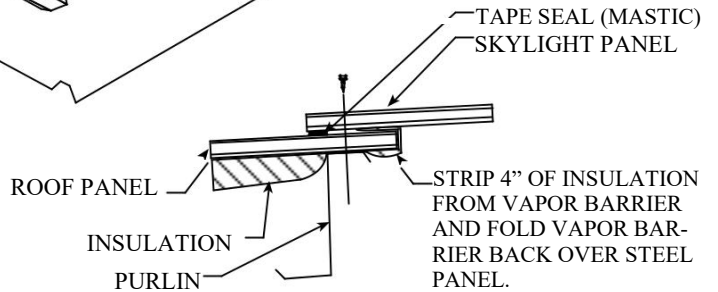

END LAP WITH INSULATION

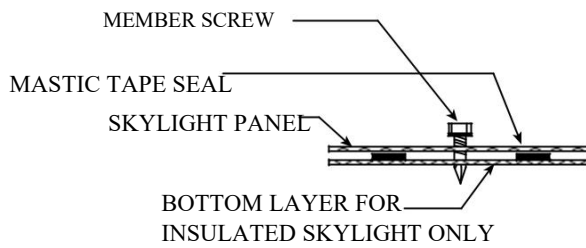

SECTION B-B

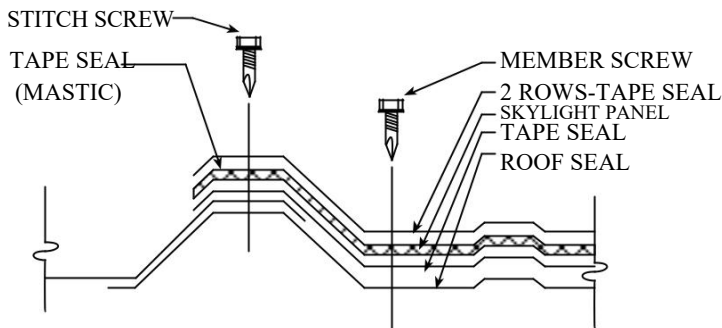

SECTION C-C

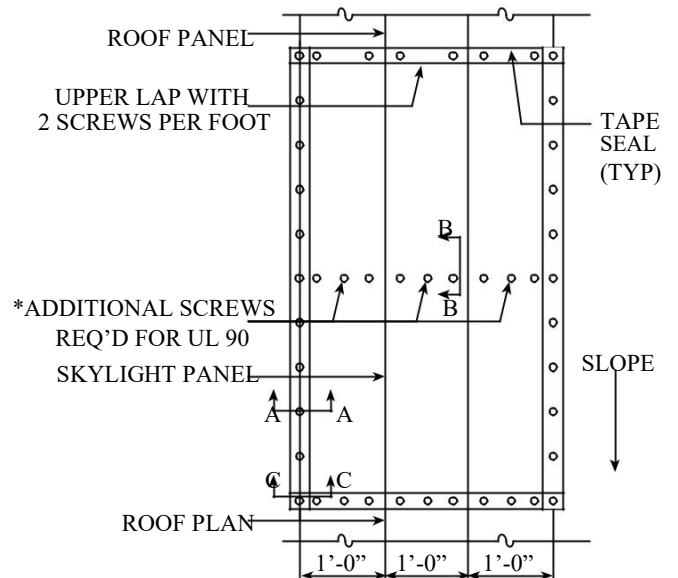

SCREW LAYOUT FOR INSULATED SKYLIGHT PANEL
*SCREW LAYOUT FOR UL-90 SKYLIGHT ASSEMBLY

SECTION 4

FLASHING, GUTTER, AND TRIM

The correct installation of flashing, gutters and trim cannot be overemphasized. The correct appearance of the finished building depends primarily on the quality of the installation of the flashing, gutters, and trim. Keep all gutter and flashing lines straight. Make all bends sharp and neat. Be sure edges are not jagged, dented, crimped, or serrated. End joints and laps must be closely controlled.

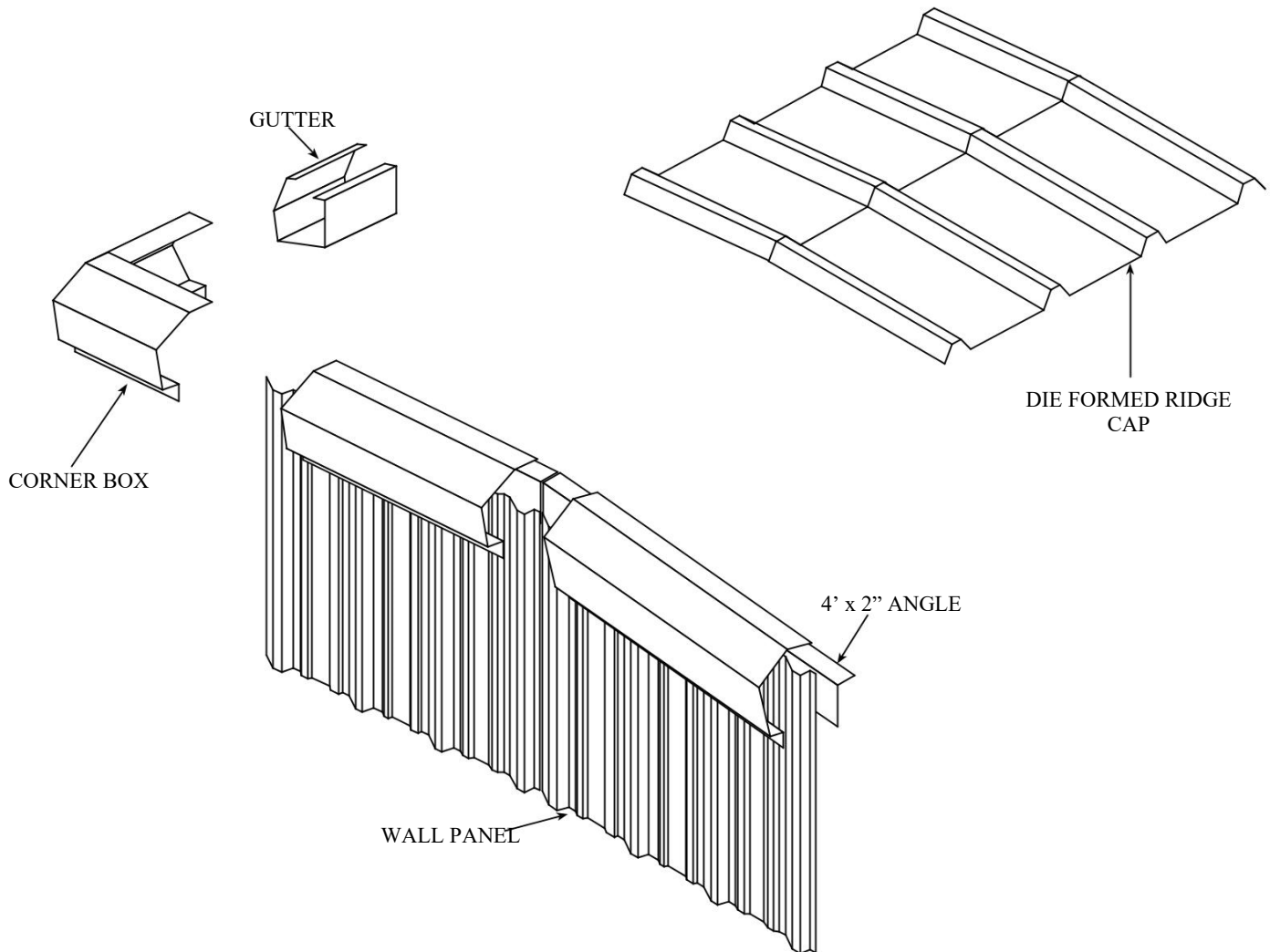

NOTE! Flashing should be stored off the ground to avoid moisture and handling damage. Elevate one end of the package above the lower end to encourage drainage in case of rain. Always wear gloves when handling sheet metal. **SAFETY FIRST!**

SECTION 4

TRIM DETAIL

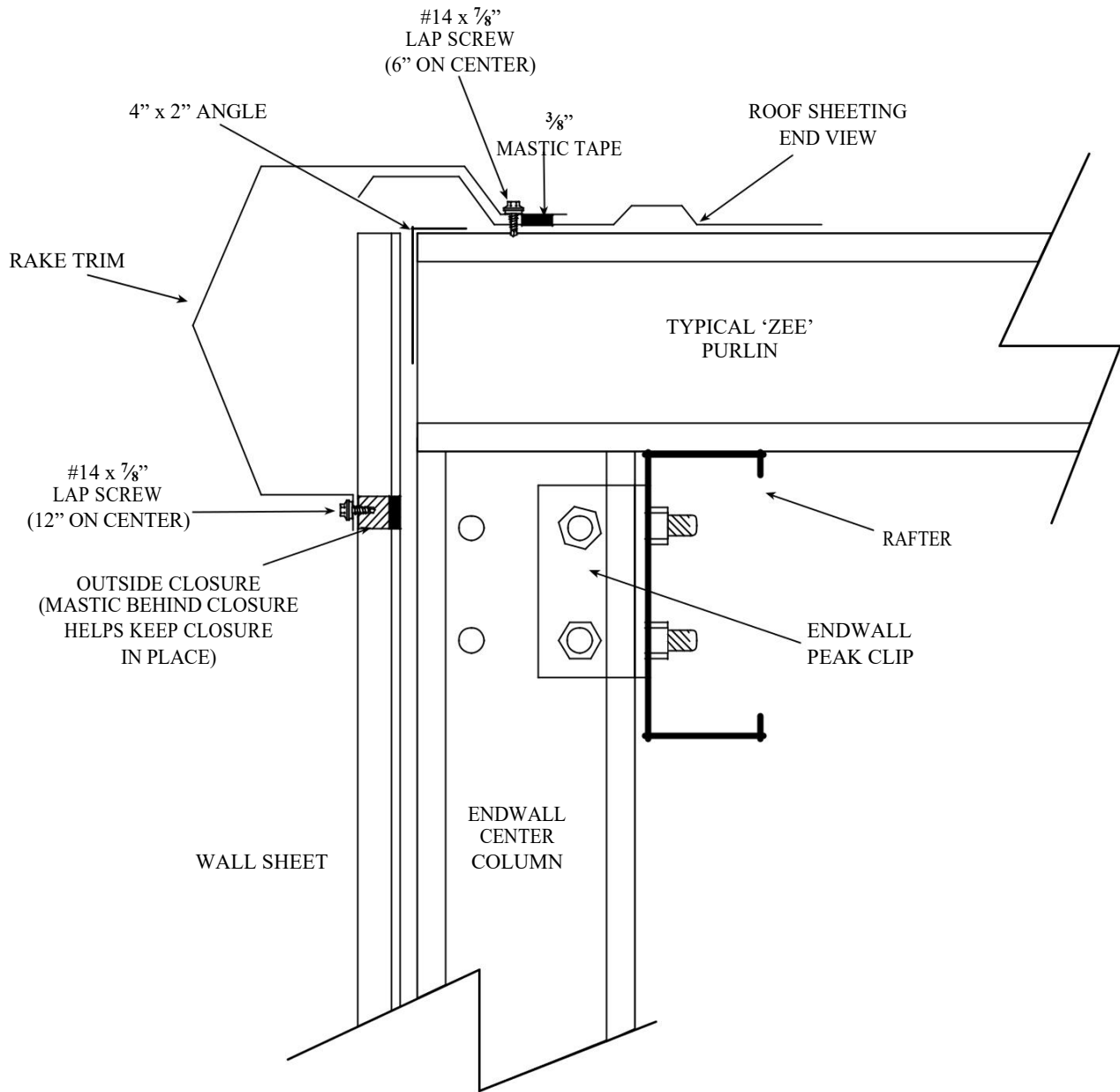

SECTION 4

RAKE TRIM ENDCAP INSTALLATION

For buildings with minimum eave trim and no gutter, install rake trim endcap as shown below. Attach to rake trim with (7) blind rivets. Trim inside and outside closures to fill void between rake trim and roof.

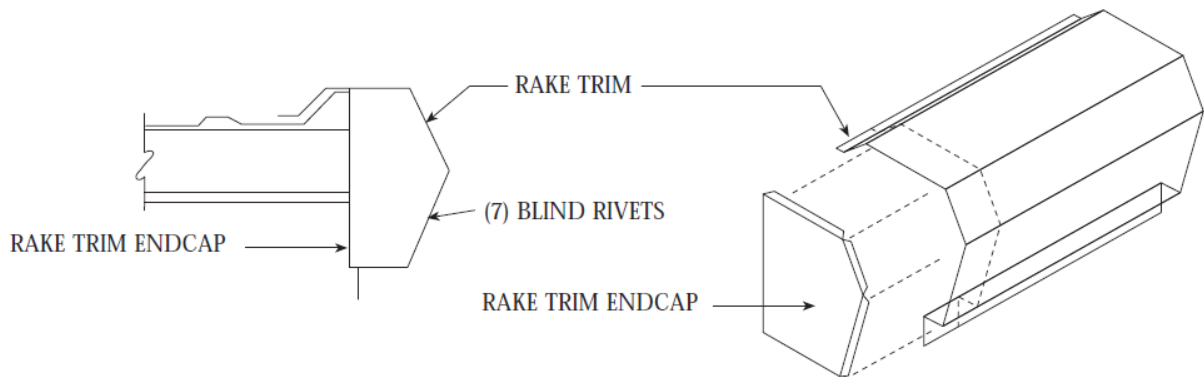

CORNER BOX INSTALLATION*

***VARIOUS BUILDING TYPES DO NOT COME WITH A CORNER BOX, ON THESE BUILDINGS THE RAKE AND EAVE TRIM MUST BE FIELD FIT AS REQUIRED.**

Caulk and install an endcap in the end of a section of gutter and fasten with blind rivets. Position the gutter and rake trim allowing a minimum of 2" overlap with the corner box. The corner box laps over the gutter and under the rake trim. An alternate method is to assemble the corner box to a section of rake or gutter and lift it into position. Align the corner box for good appearance and fasten with blind rivets. Seal connection with caulk, closure and sealant as shown. Caulk over the rivets located on top side of corner box.

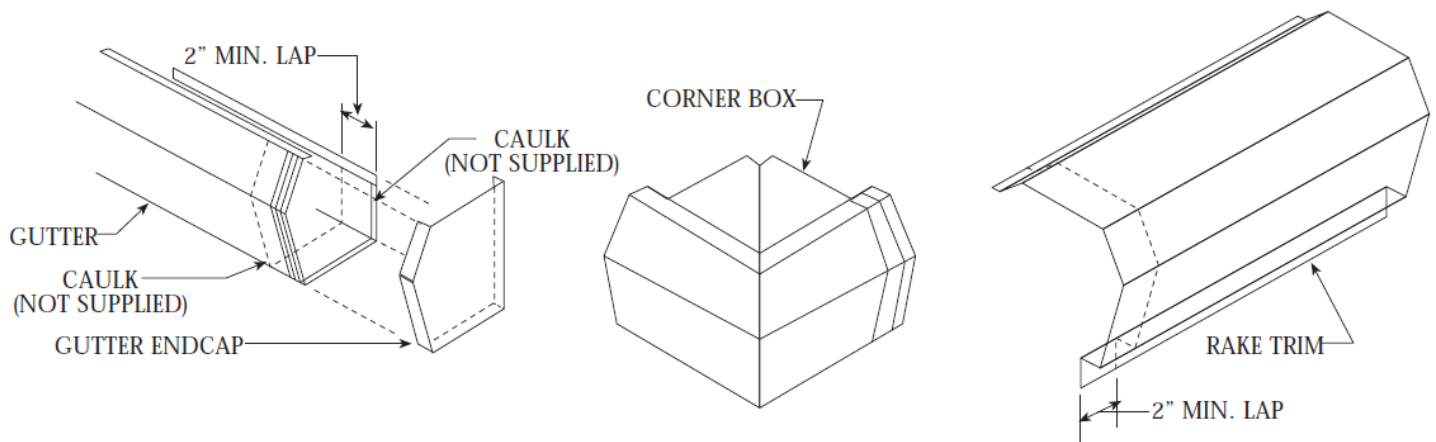

NOTE! SSBC manufactures various trim profiles - the examples shown may or may not match building in question. SAFETY FIRST!

SECTION 4

EAVE FLASHING AND GUTTER INSTALLATION

Eave flashing and/or gutters should be installed from the rear to front of the building so that the flashing or gutter sections starting at the front of the building always overlap the following sections. This will conceal any exposed raw seams when looking down the sidewall from the front (or prevailing view). Assemble as many sections of gutter as can be handled by equipment and crew on the ground and lift them into place. Gutter is not tapered on ends to fit into adjoining gutter. **Cut gutter on bends approximately 1" inch into gutter and fold in slightly to allow it to fit inside of the adjoining gutter.**

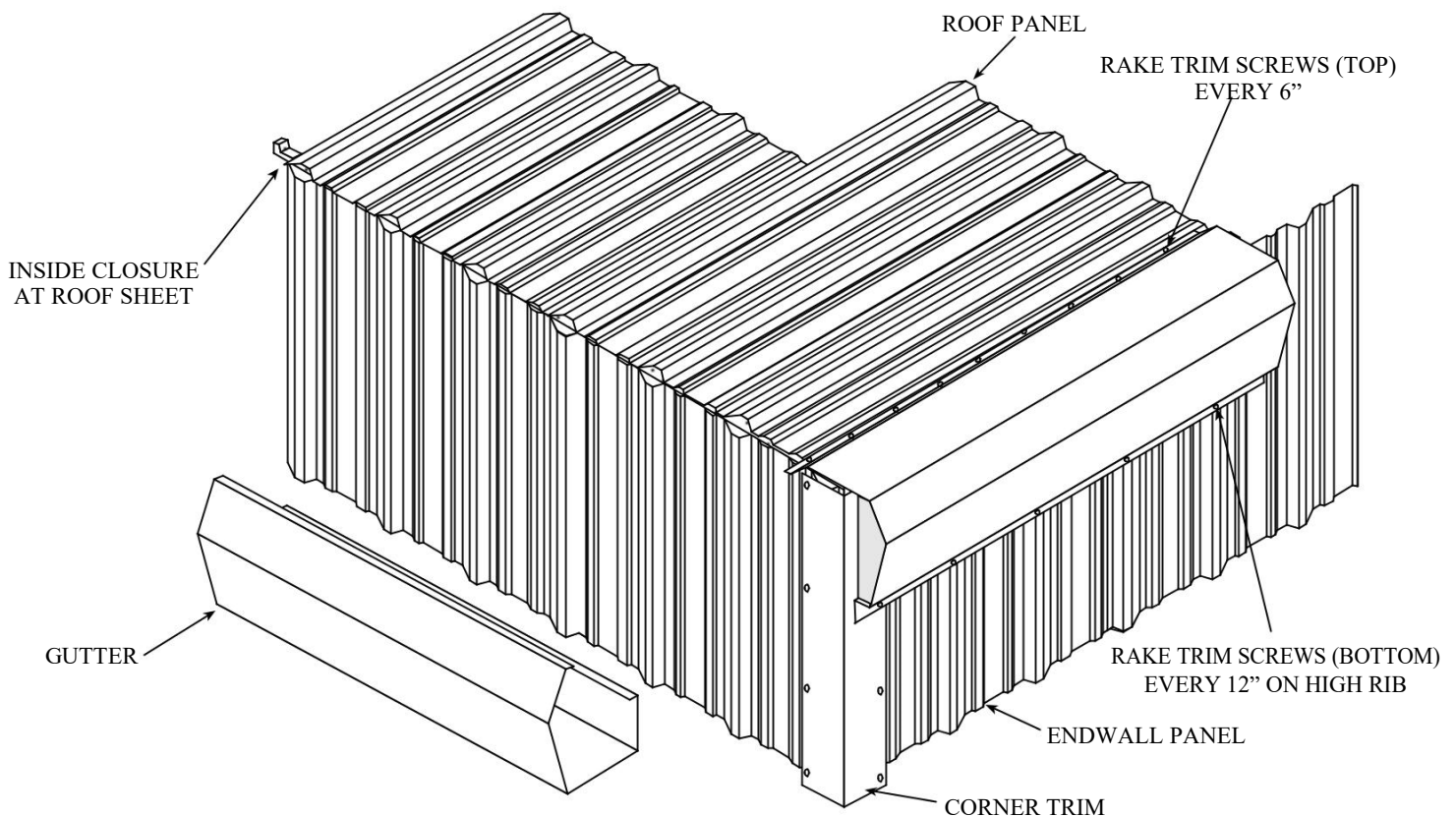

NOTE! Workers should always use gloves when handling flashing and follow all OSHA safety recommendations. Never install any material if its quality or appropriateness is in question! We manufacture various trim profiles - **the examples shown may or may not match the building in question.** SAFETY FIRST!

INSTALLING GUTTER CLIPS

SSBC gutter utilizes a bracket designed to nest over the major rib of the panel.

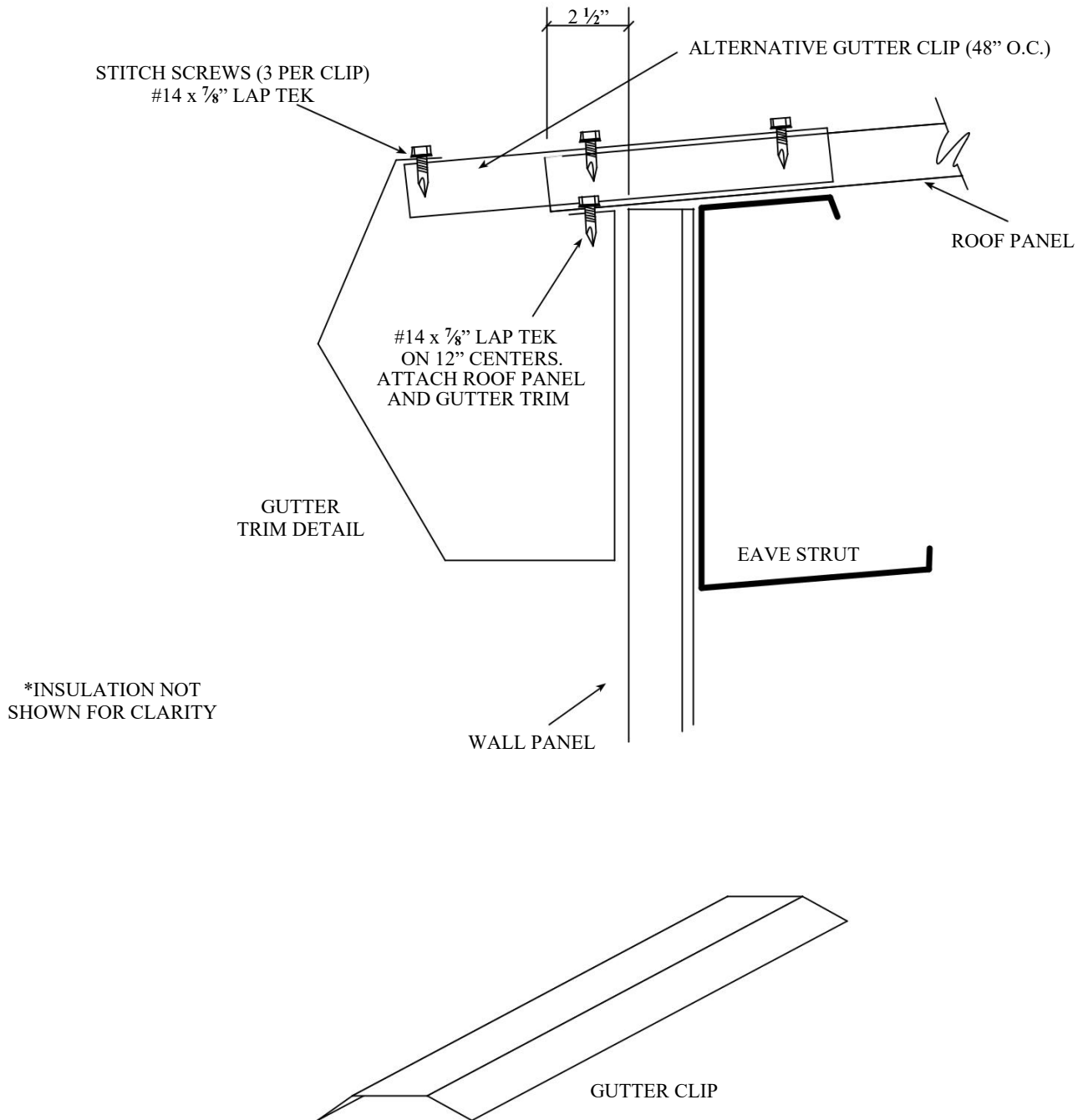

NOTE! Use extreme caution when working at the eave of the building. When snow and ice conditions exist, an alternate eave detail should be considered.

DOWNSPOUT DETAIL

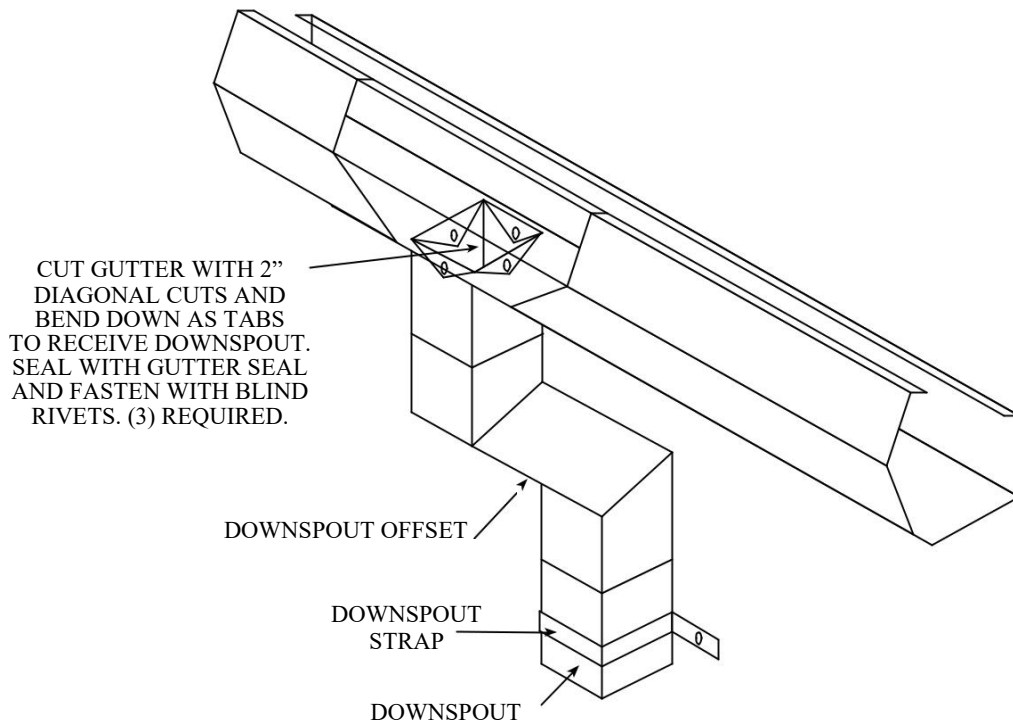

INSTALLATION OF DOWNSPOUT TO WALL PANELS (GUTTER NOT SHOWN)

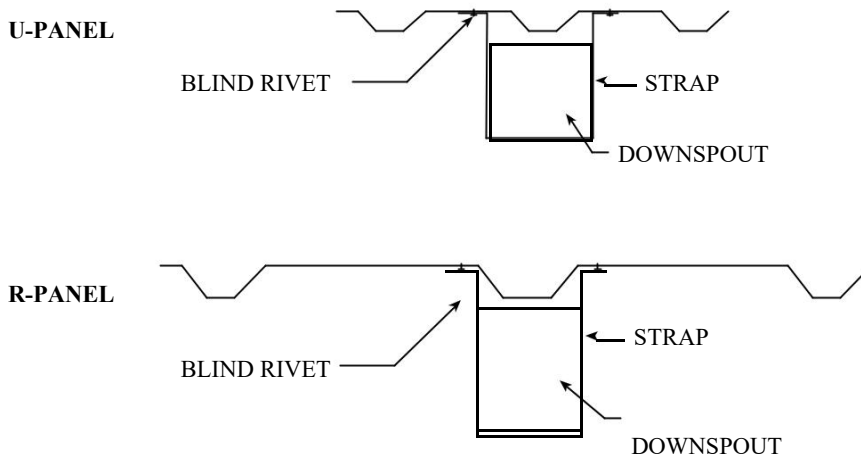

NOTE:
MAKE DOWNSPOUT
END SPLICE WITH
(3) BLIND RIVETS.

PEAK BOX INSTALLATION

Apply caulking to rake trim as shown below prior to final installation. Peak Box should lap over rake trim a minimum of 2" inches. Attach to wall panel with #12 fasteners using an outside closure to seal box at the wall. Attach box to roof with #12 roof fasteners and stitch to trim with blind rivets as shown. Seal the connection at the roof panel with $\frac{3}{8}$ " tape sealant.

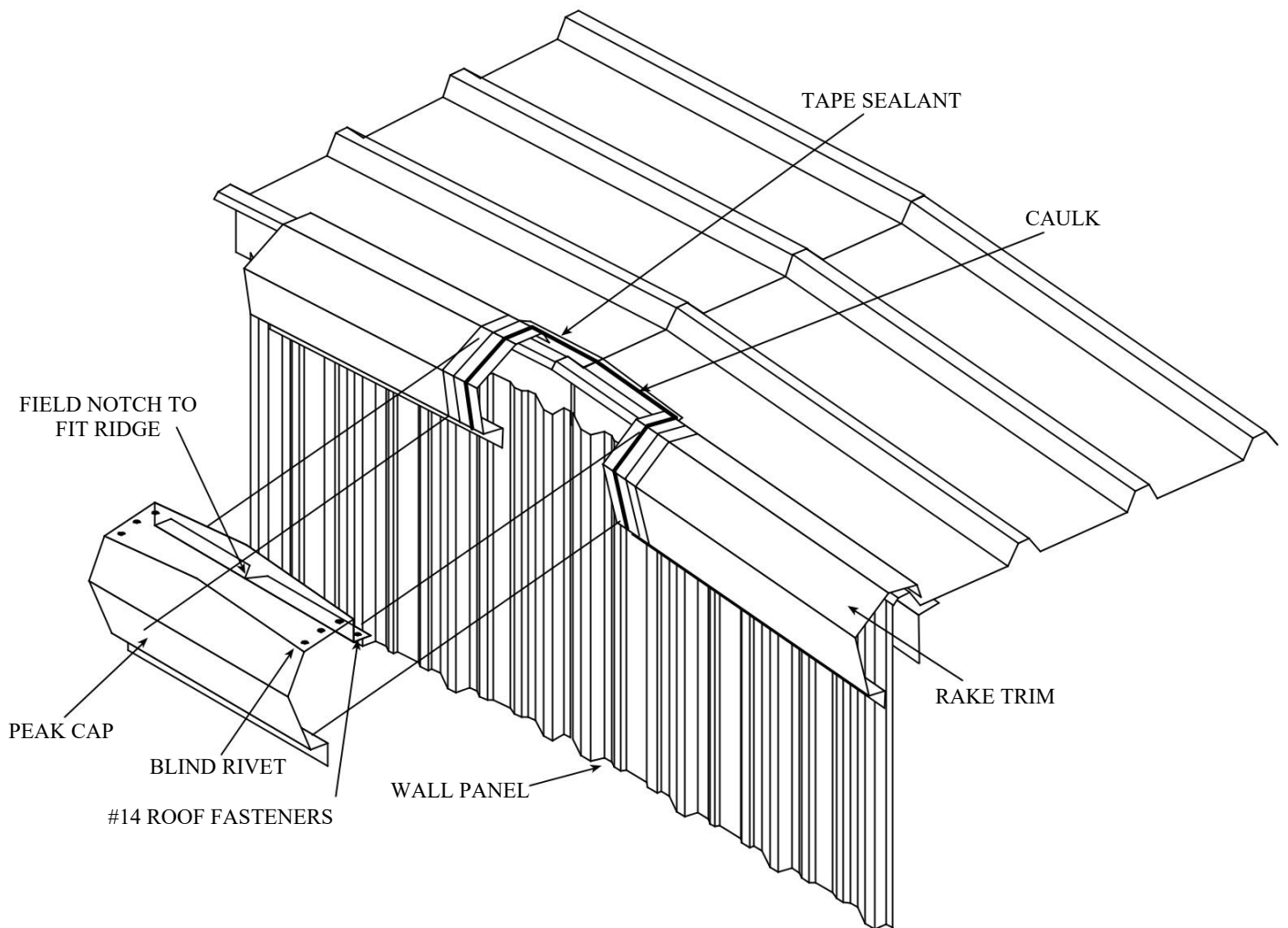

SAFETY FIRST!

GABLE OVERHANG TRIM DETAIL

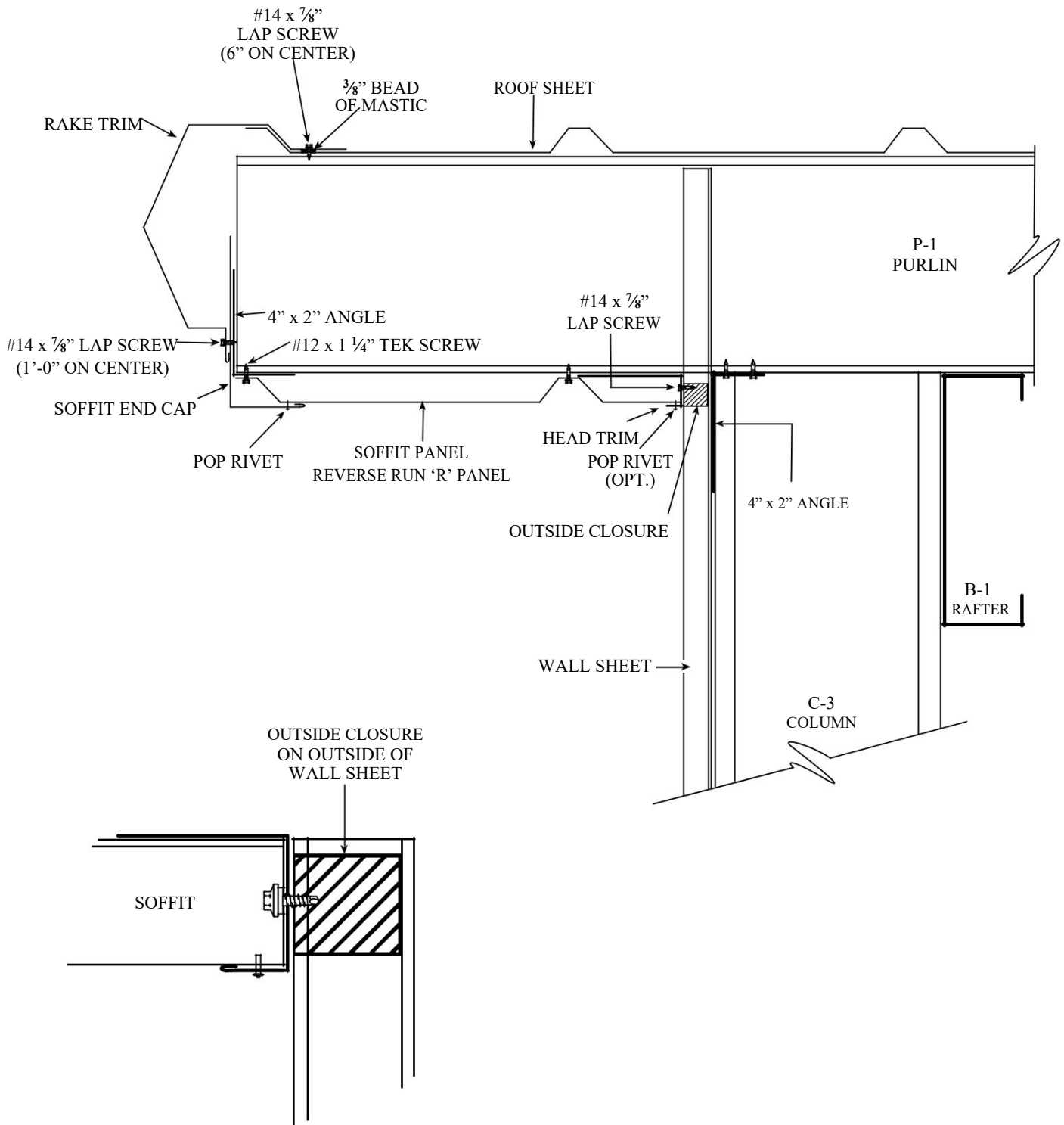

SECTION 4

EAVE OVERHANG TRIM DETAIL WITH GUTTER (TRUSS FRAME DETAIL SHOWN)

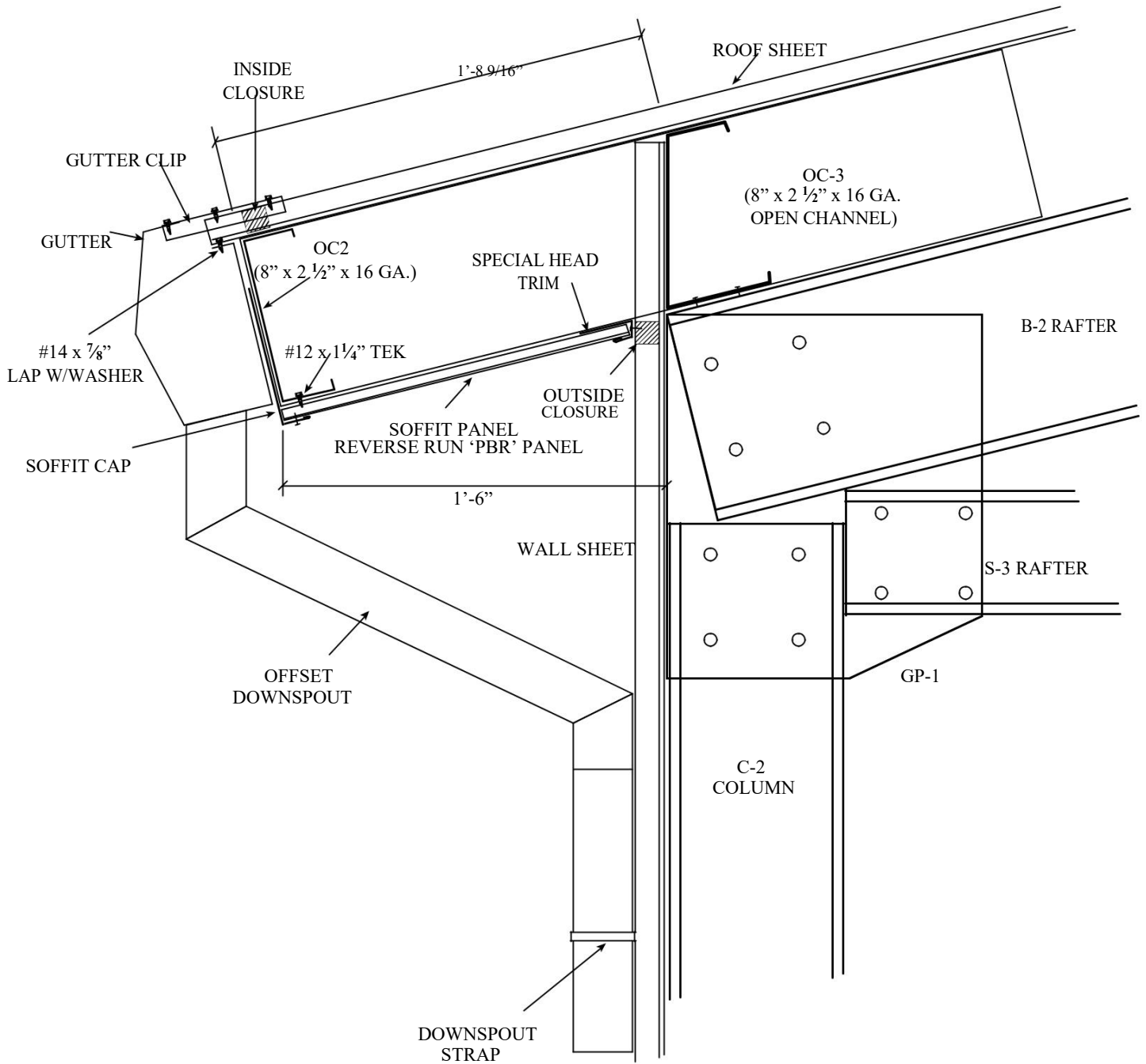

CAULK AND LAP DETAILS

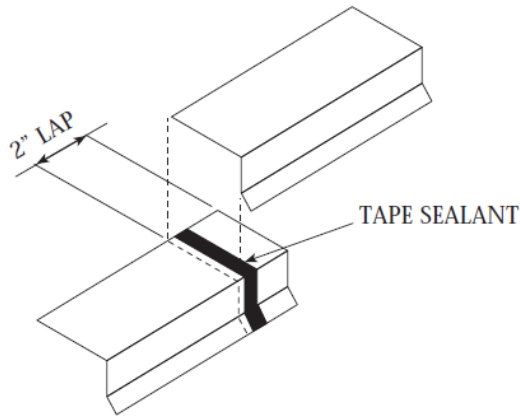

EAVE TRIM DETAIL

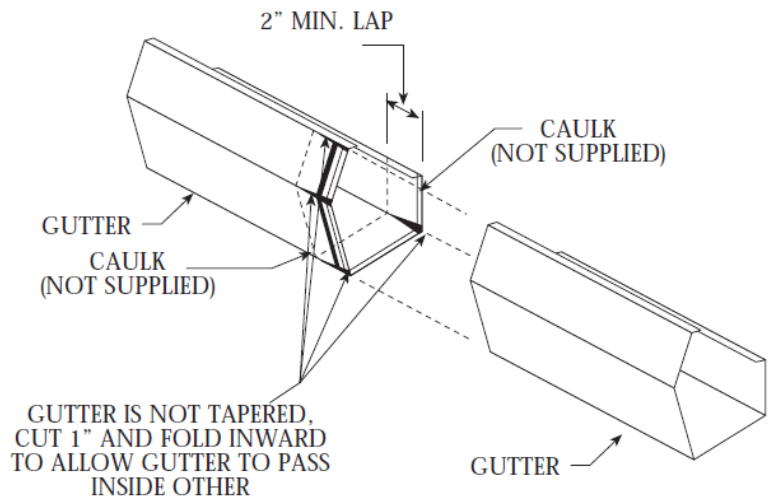

GUTTER LAP DETAIL

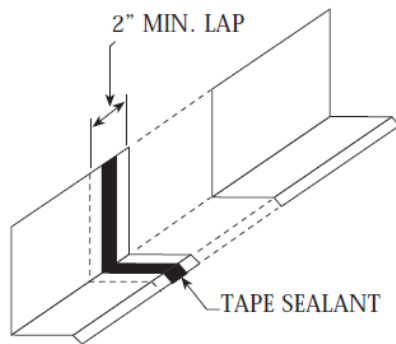

BASE TRIM DETAIL

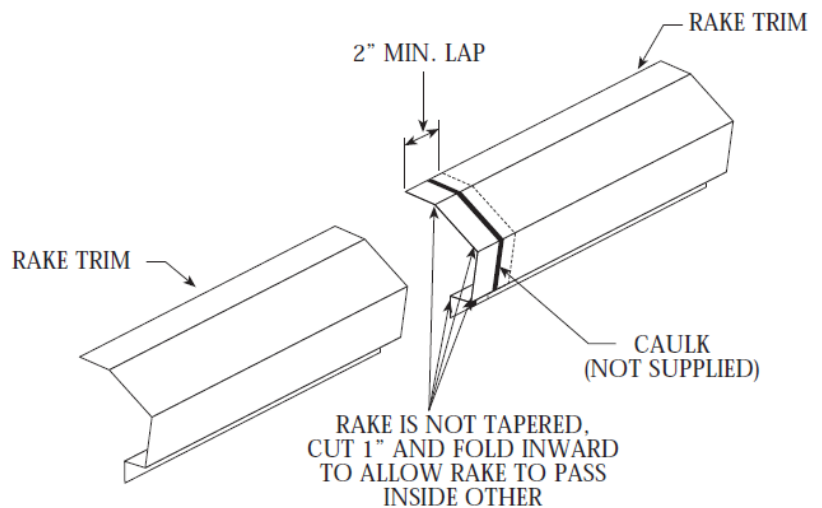

RAKE TRIM DETAIL

NOTE! *SSBC* manufactures a wide variety of trim configurations. The examples shown are meant to impress upon the erector the importance of sealants and fasteners at laps. Consult us for any questionable details.

SECTION 4

PERSONNEL DOOR FRAMED OPENING

(FURNISHED FOR LOCALLY PURCHASED DOORS ONLY)

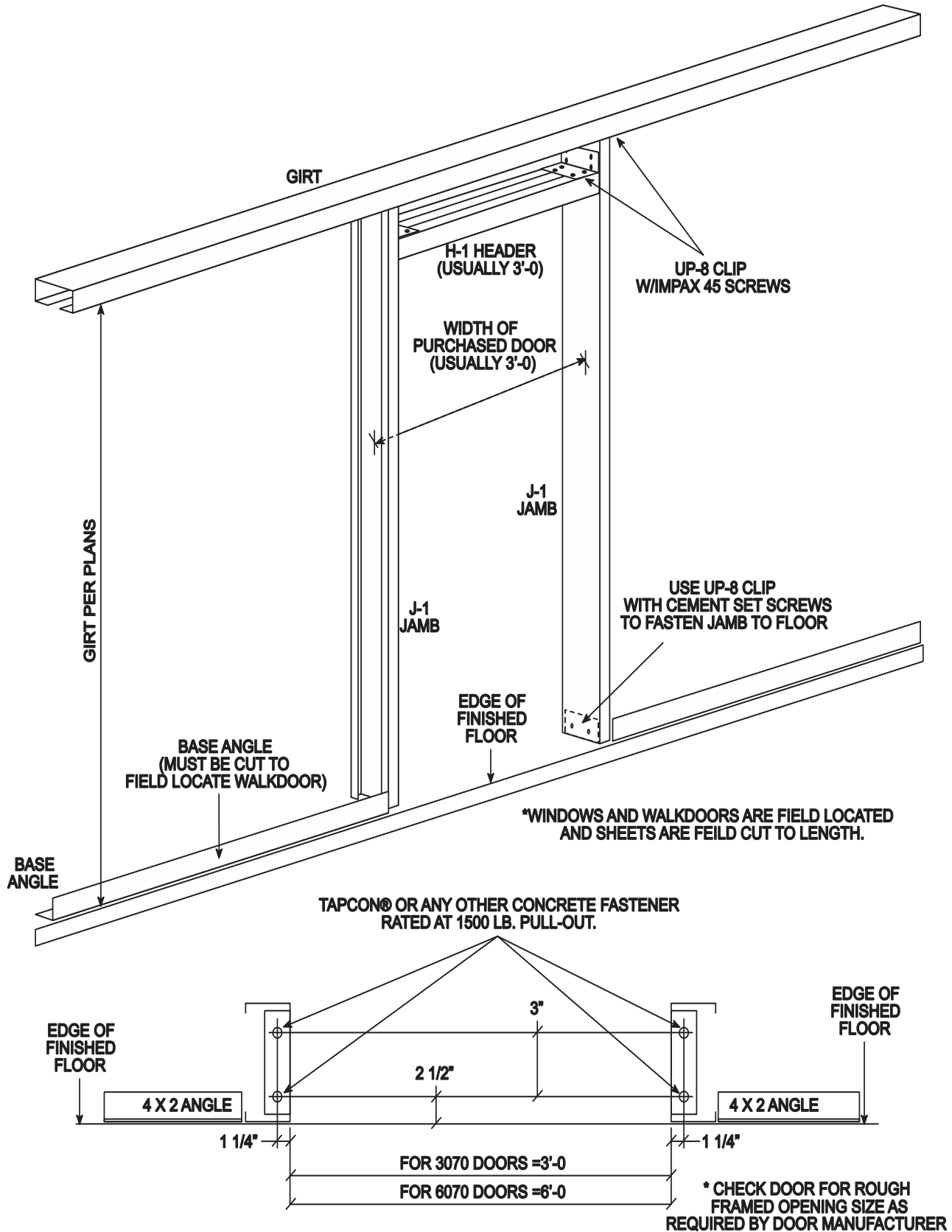

SECTION 4

SIDEWALL DETAIL

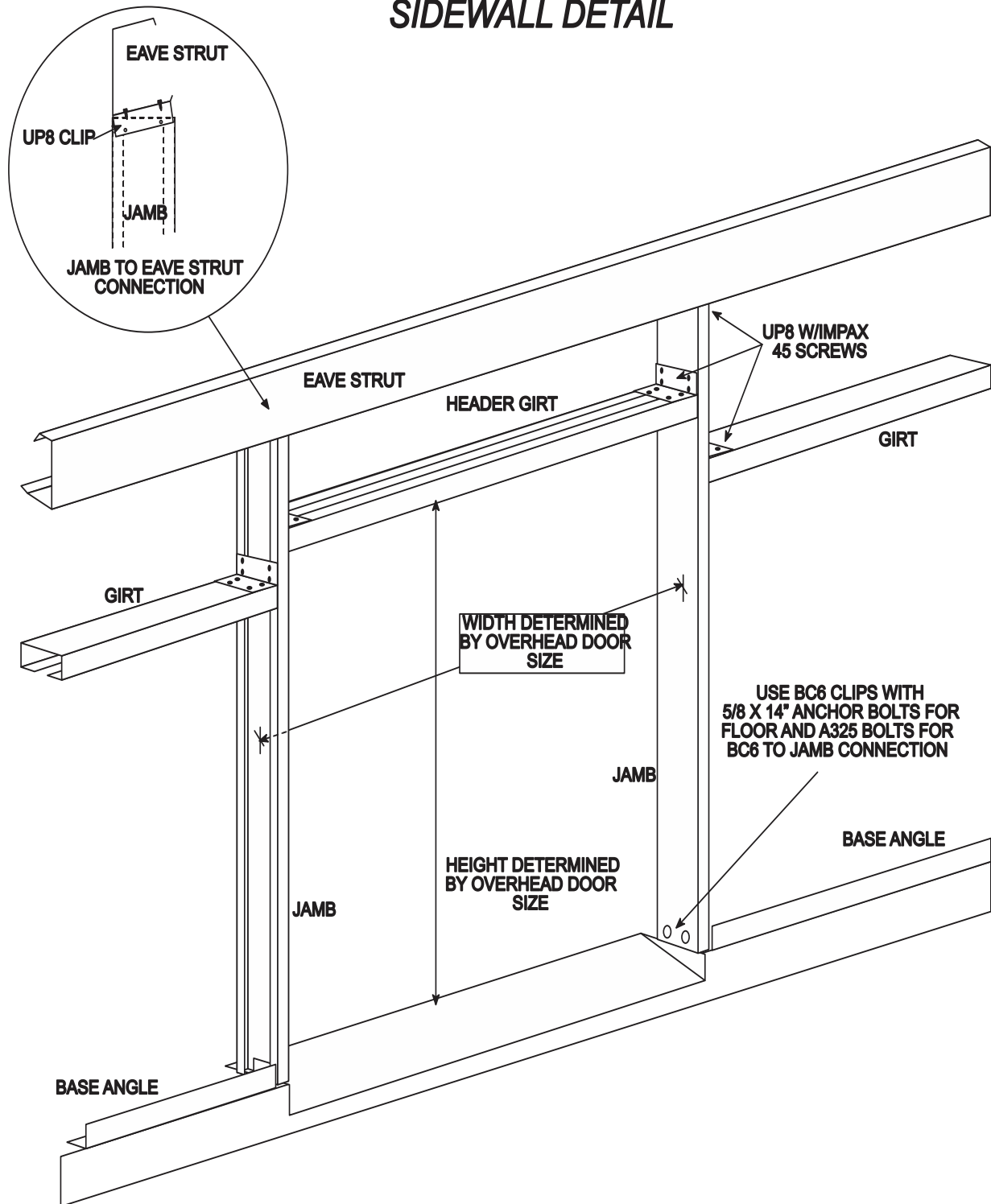

*FOR BOLT LOCATION, REFER TO DOCUMENTATION PROVIDED WITH ANCHOR BOLT PLAN

*WINDOWS AND WALKDOORS ARE FIELD LOCATED AND SHEETS ARE FEILD CUT TO LENGTH.

SECTION 4

ALUMINUM HORIZONTAL SLIDE WINDOW IN "PBR" PANEL WALL

HORIZONTAL SLIDE WINDOWS

SIZE	AVAILABLE GLAZING				AVAILABLE FINISH	
	DSB CLEAR	OBSCURE	INSULATED	BRONZE TINTED	MILL ALUM	BRONZE PAINTED
3030	STANDARD	OPTIONAL	OPTIONAL	OPTIONAL	STANDARD	STANDARD
4030	STANDARD	OPTIONAL	OPTIONAL	OPTIONAL	STANDARD	STANDARD
6030	STANDARD	OPTIONAL	OPTIONAL	OPTIONAL	STANDARD	STANDARD

GENERAL NOTES:

1. ALUMINUM HORIZONTAL SLIDE WINDOWS SHALL BE SELF-FLASHING UNITS FABRICATED FROM 6030 ALLOY, T5 TEMPER HARDNESS
2. FINISHES ARE STANDARD MILL, OR BRONZE PAINTED UPON REQUEST.
3. ALL WINDOWS SHALL BE FURNISHED WITH DOUBLE STRENGTH (D.B.S.) CLEAR GLASS AS STANDARD. WITH OBSCURE, INSULATED AND BRONZE TINTED AS AVAILABLE OPTIONS.
4. NYLON ROLLERS WILL BE ATTACHED FOR A SMOOTH SLIDING ACTION.
5. HALF SCREENS SHALL BE FURNISHED AS STANDARD FOR ALL WINDOWS.

*CHANNEL FRAMING/BASE GIRT IS REQUIRED AT WINDOW LOCATION WHEN LINER PANEL IS REQUESTED.

* WINDOWS PURCHASED FROM SIMPSON STEEL BUILDINGS DO NOT REQUIRE A HEADER GIRT OR JAMB TRIM.

* ALL WINDOWS AND WALKDOORS ARE FIELD LOCATED AND SHEETS ARE FIELD CUT TO LENGTH.

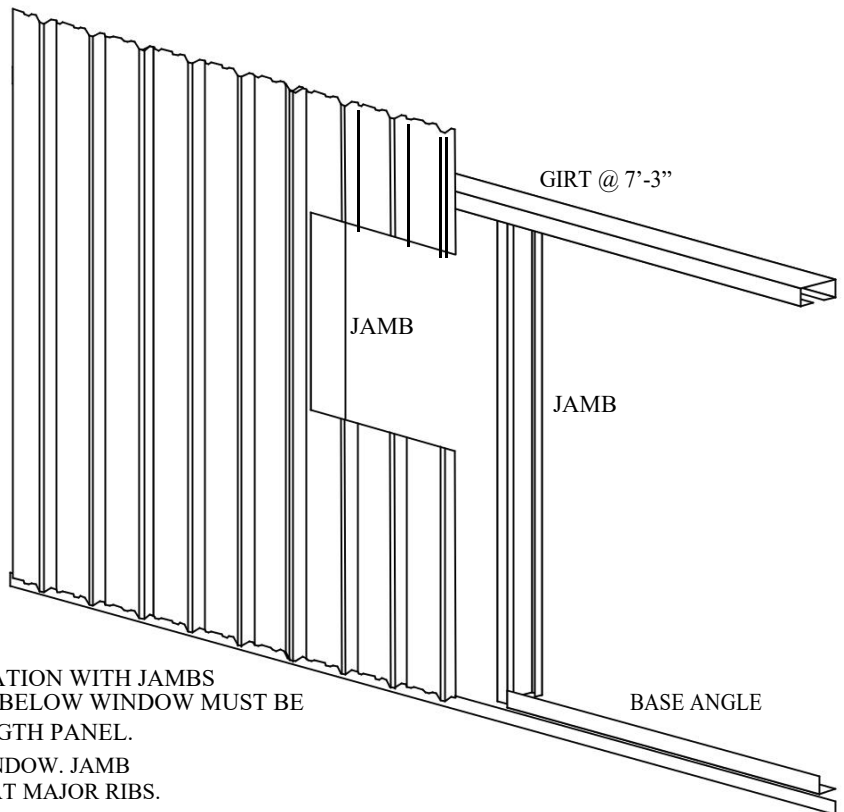

ERECTION:

1. ALL WINDOWS ARE FURNISHED FOR FIELD LOCATION WITH JAMBS LOCATED AT MAJOR RIBS. PANELS ABOVE AND BELOW WINDOW MUST BE FIELD CUT AND MAY BE CUT FROM A FULL LENGTH PANEL.
2. LOCATE JAMB STIFFENERS THE WIDTH OF THE WINDOW. JAMB STIFFENERS MUST BE LOCATED SO AS TO OCCUR AT MAJOR RIBS.
3. FOR BUILDINGS THAT HAVE A GIRT AT 3'-0" ELEVATION, THE JAMB STIFFENERS WILL BE OMITTED.
4. LOCATE WINDOW AND ATTACH TEMPORARILY WITH POP RIVETS. POP RIVETS ARE NOT INTENDED FOR ANY PURPOSE AFTER INSTALLATION OF WALL PANELS IS COMPLETE.
5. USING STANDARD PROCEDURE, ERECT WALL PANELS UP TO WINDOW LOCATION. CUT A 3'-0" SECTION FROM A FULL LENGTH PANEL AND INSTALL SHORT PANELS ABOVE AND BELOW WINDOW. BE SURE THAT FILLER STRIPS ARE POSITIONED BEFORE ATTACHING PANELS. CONTINUE WITH STANDARD WALL ERECTION PROCEDURE.
6. CAULK CONTINUOUSLY ALONG WINDOW HEADER TO INSURE A WATER TIGHT INSTALLATION.

SECTION 4

ALUMINUM HORIZONTAL SLIDE WINDOW IN "A" PANEL WALL

HORIZONTAL SLIDE WINDOWS

SIZE	AVAILABLE GLAZING				AVAILABLE FINISH	
	DSB CLEAR	OBSCURE	INSULATED	BRONZE TINTED	MILL ALUM	BRONZE PAINTED
3030	STANDARD	OPTIONAL	OPTIONAL	OPTIONAL	STANDARD	STANDARD
4030	STANDARD	OPTIONAL	OPTIONAL	OPTIONAL	STANDARD	STANDARD
6030	STANDARD	OPTIONAL	OPTIONAL	OPTIONAL	STANDARD	STANDARD

GENERAL NOTES:

1. ALUMINUM HORIZONTAL SLIDE WINDOWS SHALL BE SELF-FLASHING UNITS FABRICATED FROM 6030 ALLOY, T5 TEMPER HARDNESS
2. FINISHES ARE STANDARD MILL, OR BRONZE PAINTED UPON REQUEST.
3. ALL WINDOWS SHALL BE FURNISHED WITH DOUBLE STRENGTH (D.B.S.) CLEAR GLASS AS STANDARD. WITH OBSCURE, INSULATED AND BRONZE TINTED AS AVAILABLE OPTIONS.
4. NYLON ROLLERS WILL BE ATTACHED FOR A SMOOTH SLIDING ACTION.
5. HALF SCREENS SHALL BE FURNISHED AS STANDARD FOR ALL WINDOWS.

*CHANNEL FRAMING/BASE GIRT IS REQUIRED AT WINDOW LOCATION WHEN LINER PANEL IS REQUESTED.

* WINDOWS PURCHASED FROM SIMPSON STEEL BUILDINGS DO NOT REQUIRE A HEADER GIRT OR JAMB TRIM.

* ALL WINDOWS AND WALKDOORS ARE FIELD LOCATED AND SHEETS ARE FIELD CUT TO LENGTH.

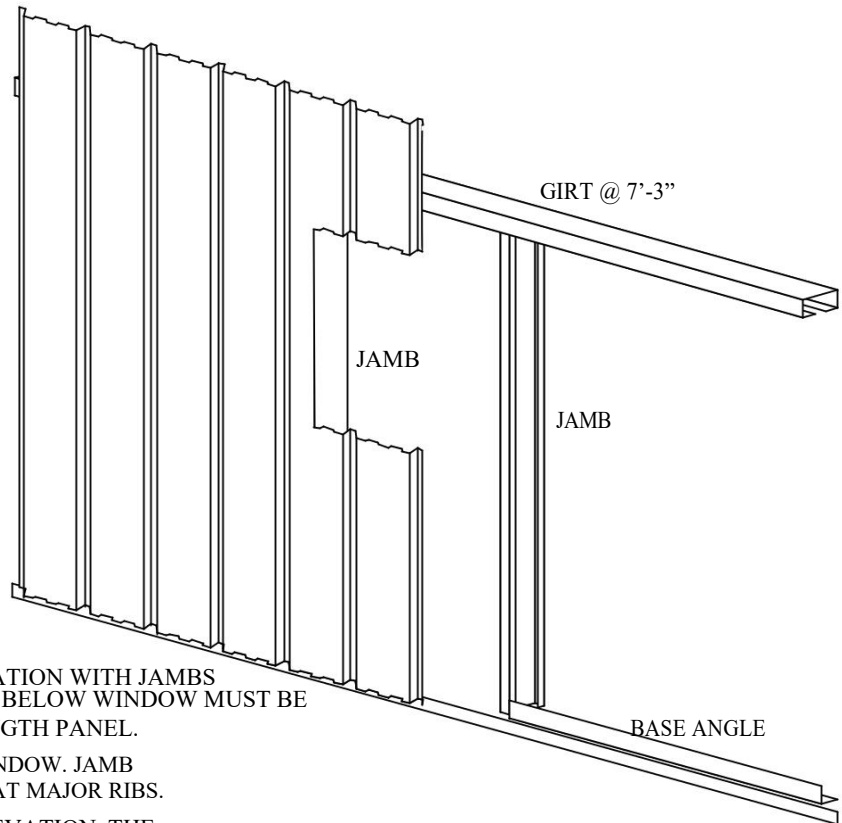

ERECTION:

1. ALL WINDOWS ARE FURNISHED FOR FIELD LOCATION WITH JAMBS LOCATED AT MAJOR RIBS. PANELS ABOVE AND BELOW WINDOW MUST BE FIELD CUT AND MAY BE CUT FROM A FULL-LENGTH PANEL.
2. LOCATE JAMB STIFFENERS THE WIDTH OF THE WINDOW. JAMB STIFFENERS MUST BE LOCATED SO AS TO OCCUR AT MAJOR RIBS.
3. FOR BUILDINGS THAT HAVE A GIRT AT 3'-0" ELEVATION, THE JAMB STIFFENERS WILL BE OMITTED.
4. LOCATE WINDOW AND ATTACH TEMPORARILY WITH POP RIVETS. POP RIVETS ARE NOT INTENDED FOR ANY PURPOSE AFTER INSTALLATION OF WALL PANELS IS COMPLETE.
5. USING STANDARD PROCEDURE, ERECT WALL PANELS UP TO WINDOW LOCATION. CUT A 3'-0" SECTION FROM A FULL-LENGTH PANEL AND INSTALL SHORT PANELS ABOVE AND BELOW WINDOW. BE SURE THAT FILLER STRIPS ARE POSITIONED BEFORE ATTACHING PANELS. CONTINUE WITH STANDARD WALL ERECTION PROCEDURE.
6. CAULK CONTINUOUSLY ALONG WINDOW HEADER TO INSURE A WATER TIGHT INSTALLATION.

SECTION 4

WAINSCOT DETAIL WITH TRIM AT CORNER ON SIDEWALL

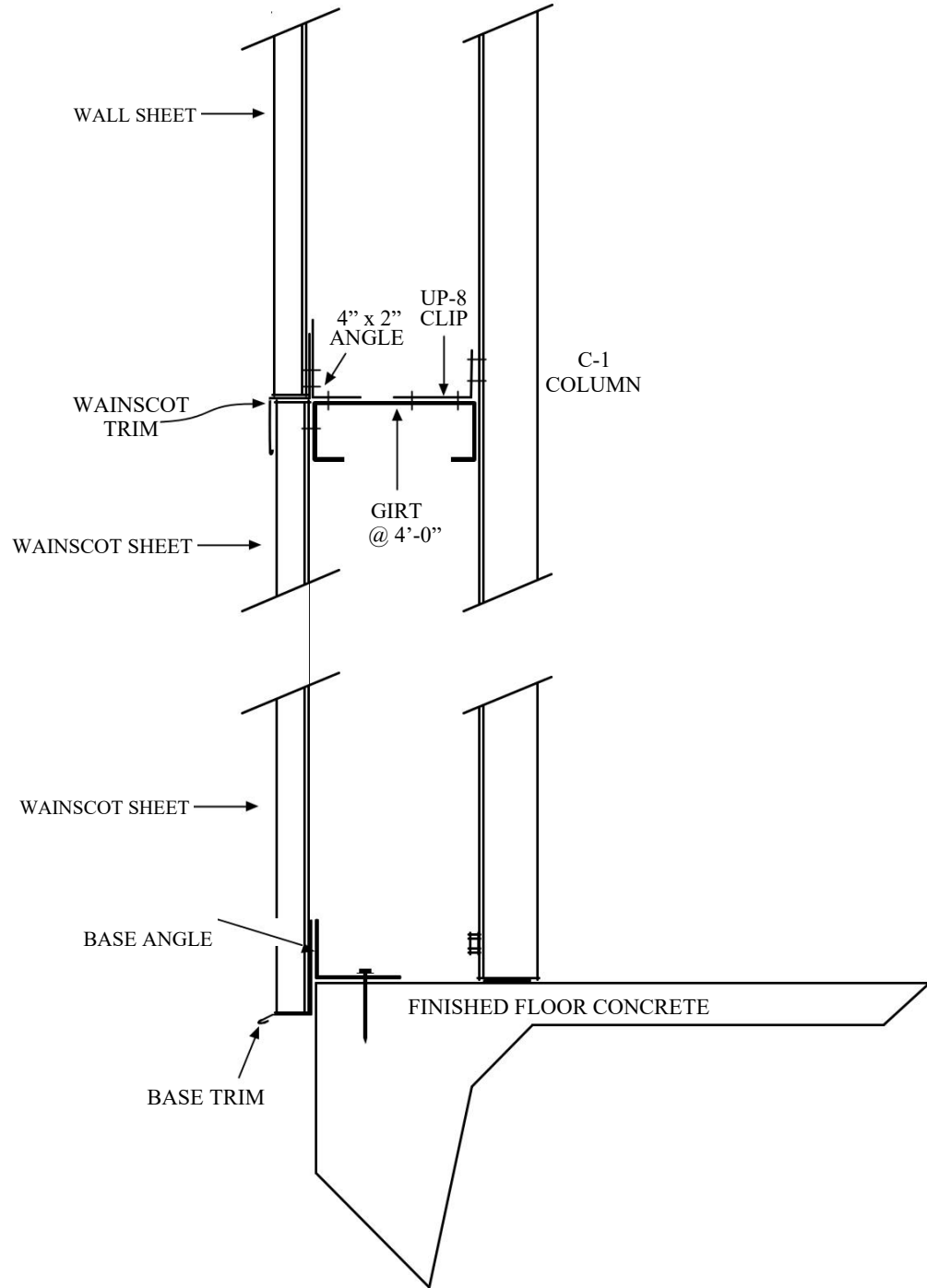

WAINSCOT DETAIL W/ TRIM PIECES

FRAMED OPENING JAMB TRIM DETAIL

TOP-DOWN VIEW

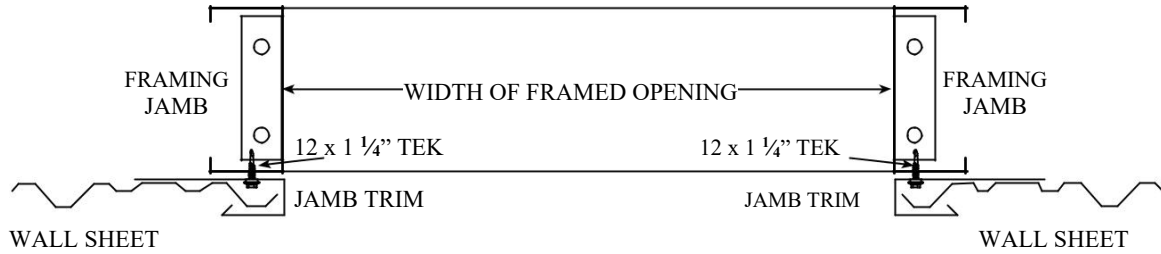

NOTE! Attach jamb trim first, then cut wall sheets around framed opening.

FRAMED OPENING HEAD TRIM DETAIL

CROSS SECTION VIEW FROM SIDE

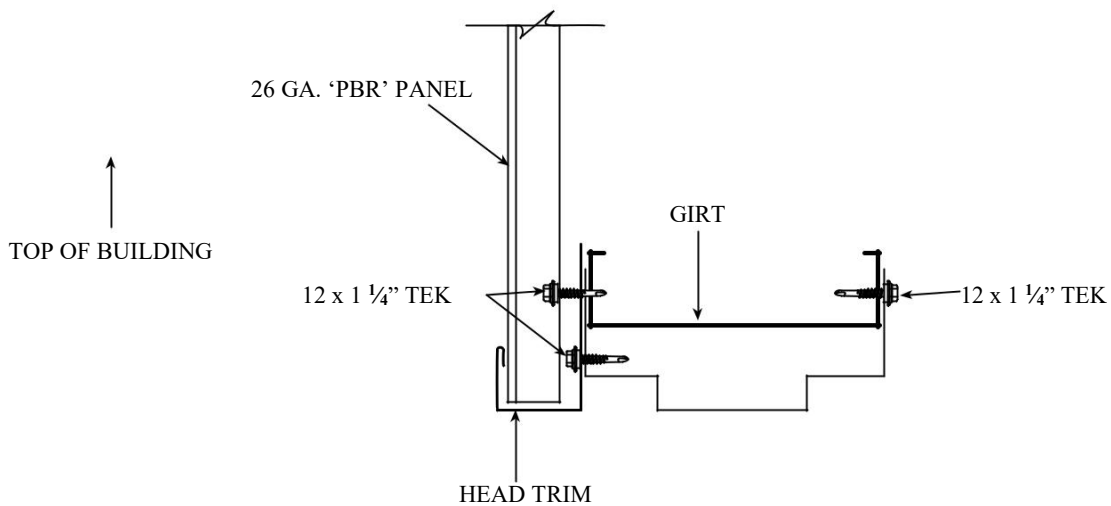

NOTE! Attach jamb trim first, then cut wall sheets around framed opening.

2 BOLT ANCHOR BOLT DIAGRAM (FOR ENDWALLS - NOT TO SCALE)

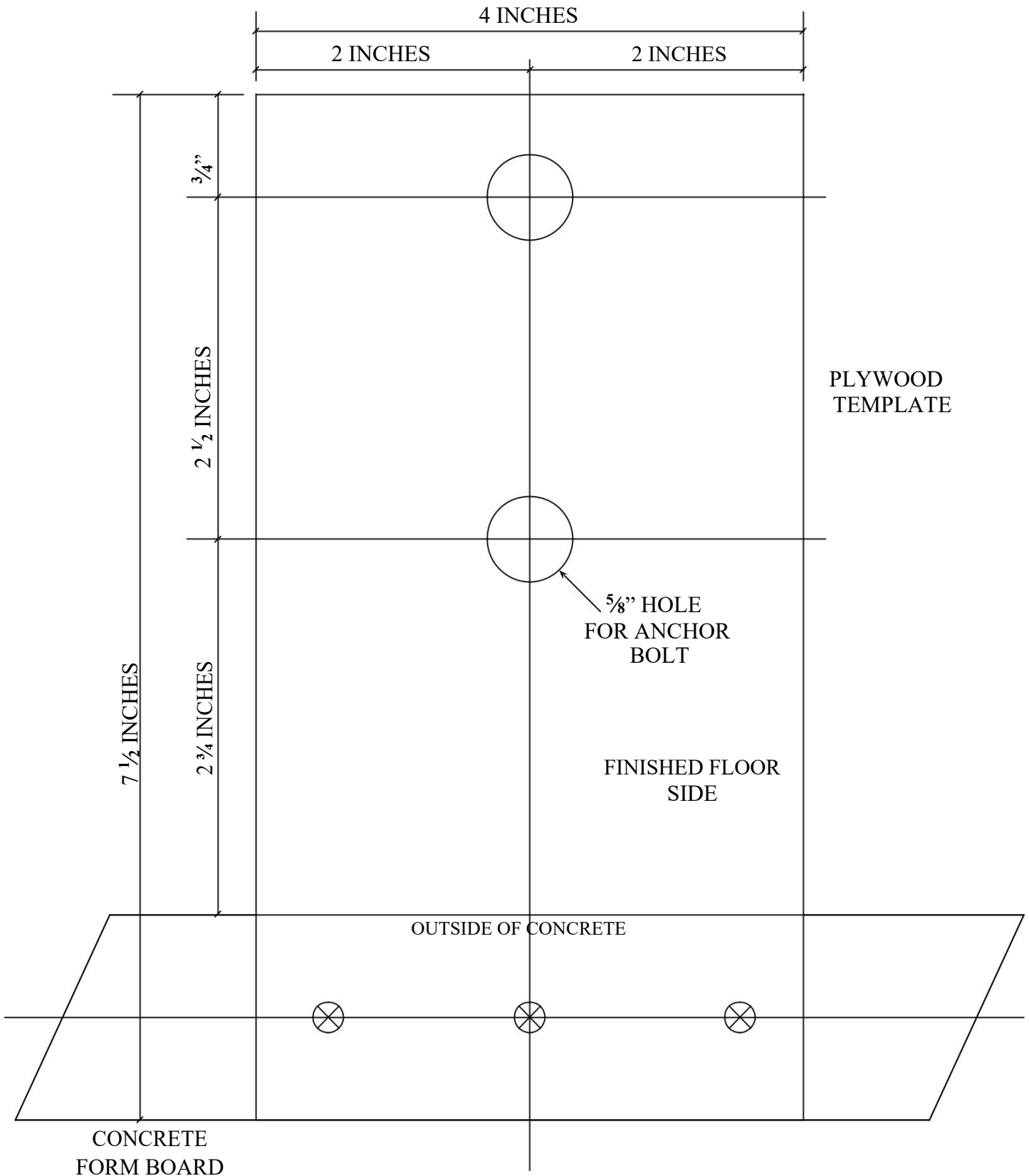

4 BOLT ANCHOR BOLT DIAGRAM (FOR SIDEWALLS - NOT TO SCALE)

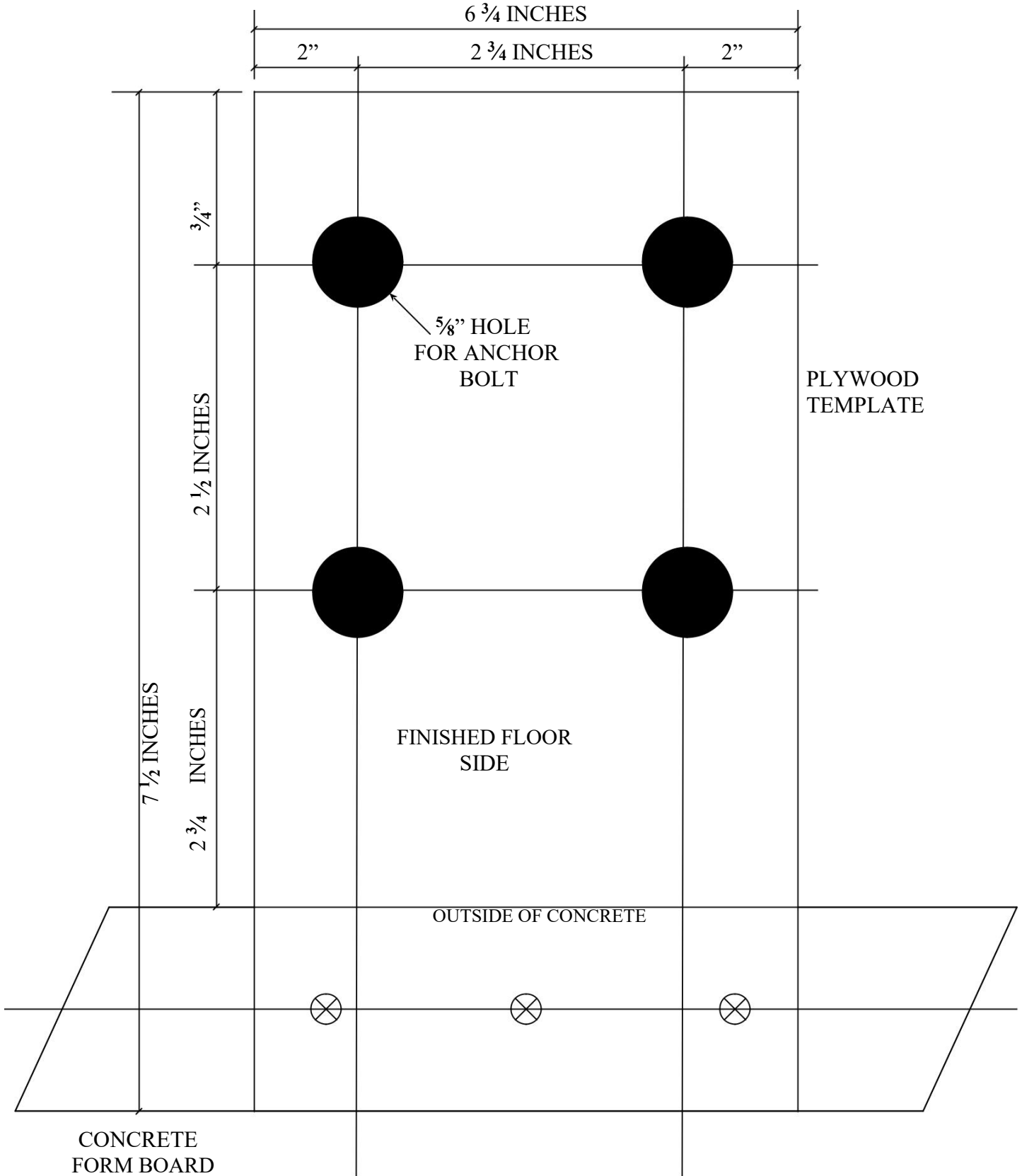

CABLE BRACE INSTALLATION

1. Field cut slots in noted areas for cable bracing.
2. After slotting columns, slot sidewall-girts to allow cable to pass through center of girt to align with slots in columns. (Sidewall and Endwall cable brace only)
3. Attach eye bolt assembly on one end only of cable and put through high point in column.
4. Thread opposite end (without eye bolt assembly) through slots in the sidewall-girt slots to bottom slot in opposing column.
5. Attach the remaining eye bolt assembly for that cable and position the eye bolt assembly through bottom slot in the column.
6. Tighten cable by tightening square nut on eye bolt until cable is snug-tight, but without pulling the building out of square.
7. Roof cable will only pass through slots in rafters as stated in details. The cable is positioned on diagonal from one end of rafter to opposite end of opposing rafter without going through any other roof members. (Roof cable does not pass through roof-purlins).
8. If cable is required in the end bay of a side wall, this can be attached with a cable brace clip (if supplied) that would attach horizontally to the second set of holes at the top and bottom of the corner column, or it can be attached to the side of the column rather than the face.
9. For any cables that need to connect at the bottom of a door jamb, add a second BC-6 clip to the bottom of the jamb (turned in the opposite direction) and place the eyebolt through the clip (rather than the jamb). This will avoid interference with the inside of the door jamb.

CABLE BRACE INSTALLATION

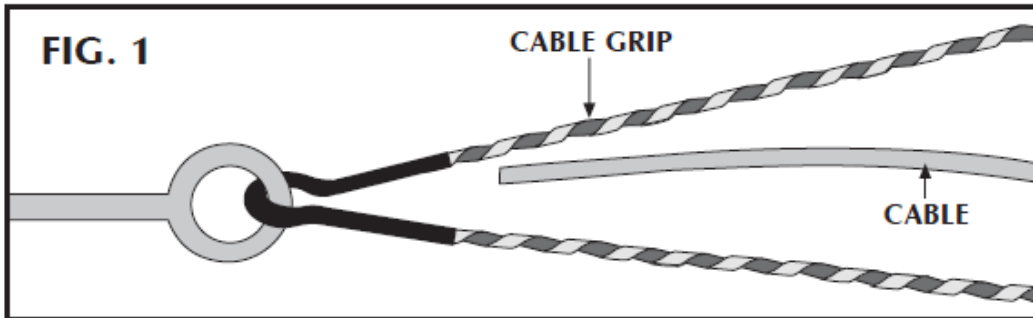

LOCATE CABLE AND HARDWARE.

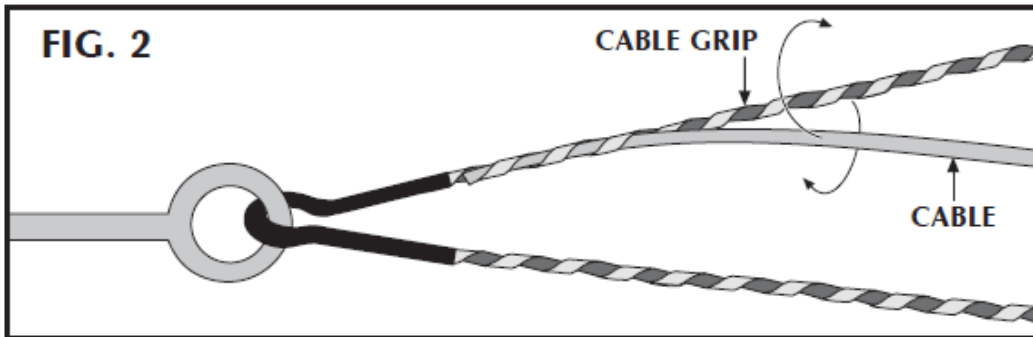

WRAP ONE LEG OF CABLE GRIP AROUND CABLE.

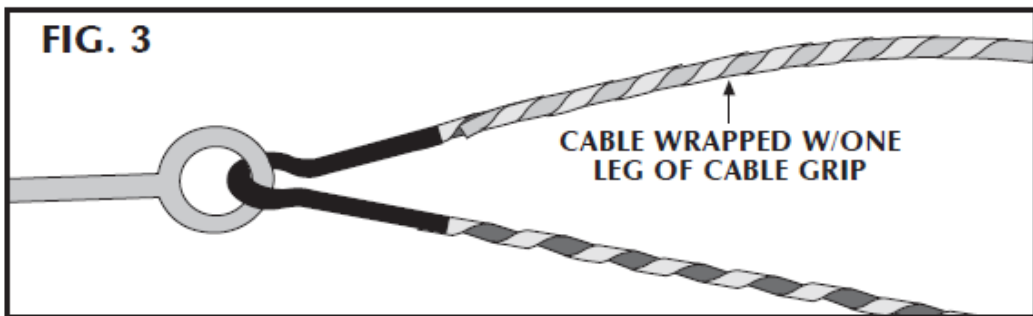

AFTER FIRST SIDE IS COMPLETED, LOCATE REMAINING SIDE OF CABLE GRIP.

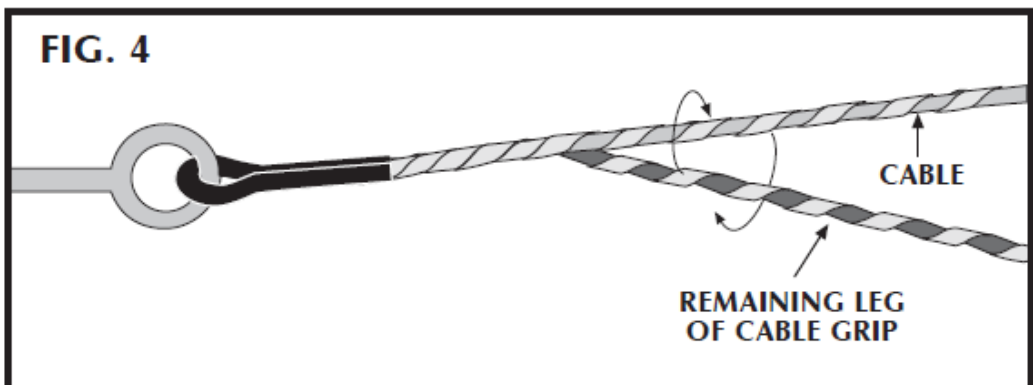

WRAP SECOND LEG OF CABLE GRIP AROUND CABLE.

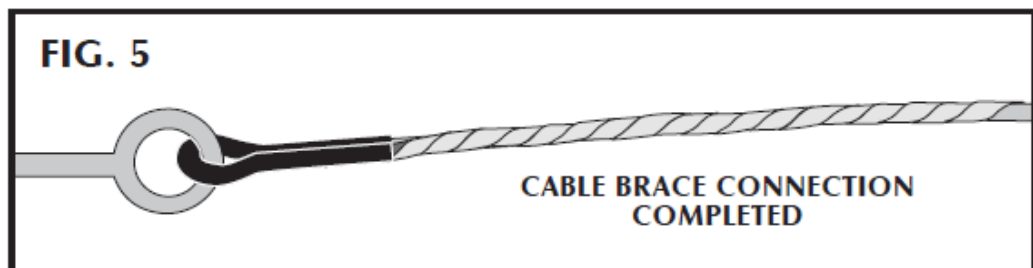

CABLE BRACE CONNECTION IS NOW COMPLETE.

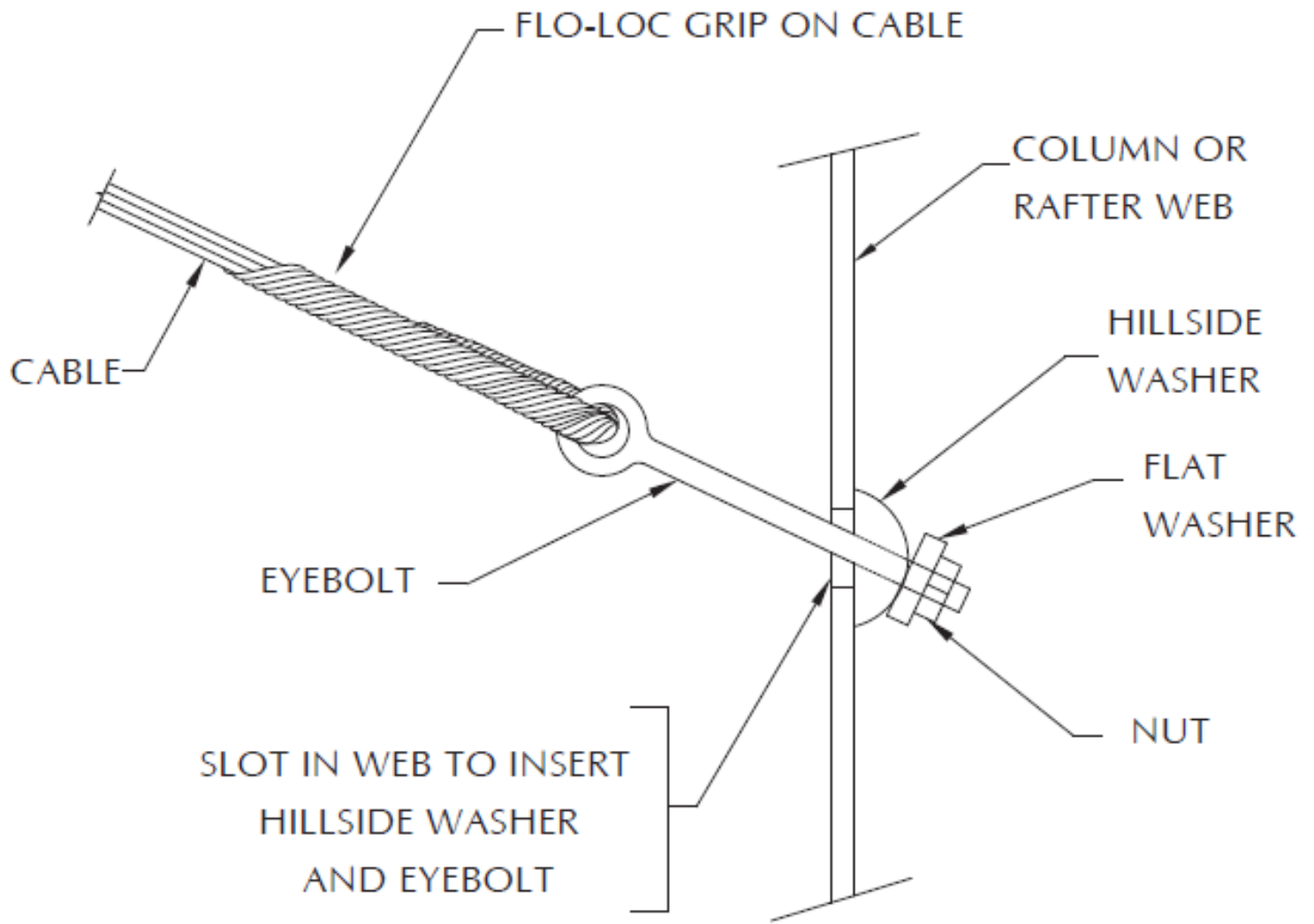

CABLE BRACE DETAIL

CABLE BRACING

CABLE BRACE SLOT LOCATIONS DETAIL

NOTE: FIELD CUT
SLOTS IN RAFTERS
FOR EYE BOLTS
FOR CABLE BRACING

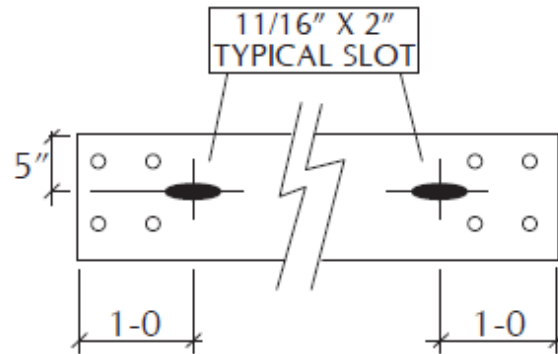

CABLE BRACE (ROOF)

NOTE: FIELD CUT
SLOTS IN COLUMNS
FOR EYE BOLTS
FOR CABLE BRACING

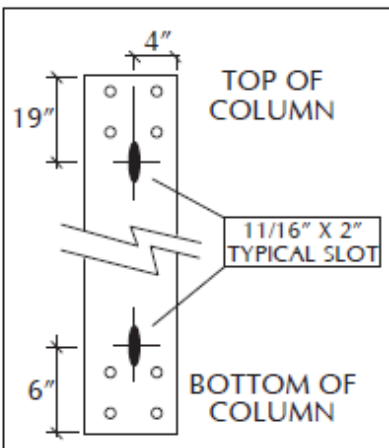

CORNER COLUMNS

NOTE: FIELD CUT
SLOTS IN COLUMNS
FOR EYE BOLTS
FOR CABLE BRACING

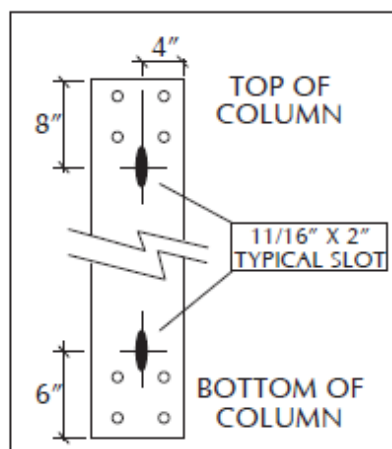

TRUSS COLUMNS

CABLE BRACE (SIDEWALLS)

NOTE: FIELD CUT
SLOTS IN COLUMNS
FOR EYE BOLTS
FOR CABLE BRACING

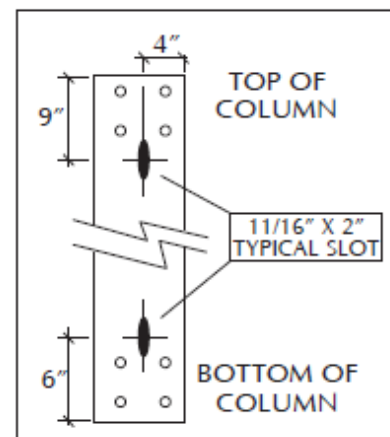

CENTER & CORNER
COLUMNS

CABLE BRACE (ENDWALLS)

LEAN-TO FOUNDATION

LEAN-TO FOUNDATION

SSBC lean-to designs account for the foundational items listed below. You need to consider these items when preparing your lean-to foundation:

1. The main building's concrete edge needs to have a 1-1/2" x 1-1/2" notch or "apron" to allow for the main building sheeting.
2. There will be a 2" drop across the width of the lean-to from where it starts to where it ends. This is to help shed water away from the building.
3. Taking into account the notes above, that will make the total drop of the outer edge of the lean-to concrete 3-1/2". Lean-to column lengths are automatically computed to include this additional 3-1/2", unless otherwise specified.

LEAN-TO FOUNDATION ENDWALL VIEW

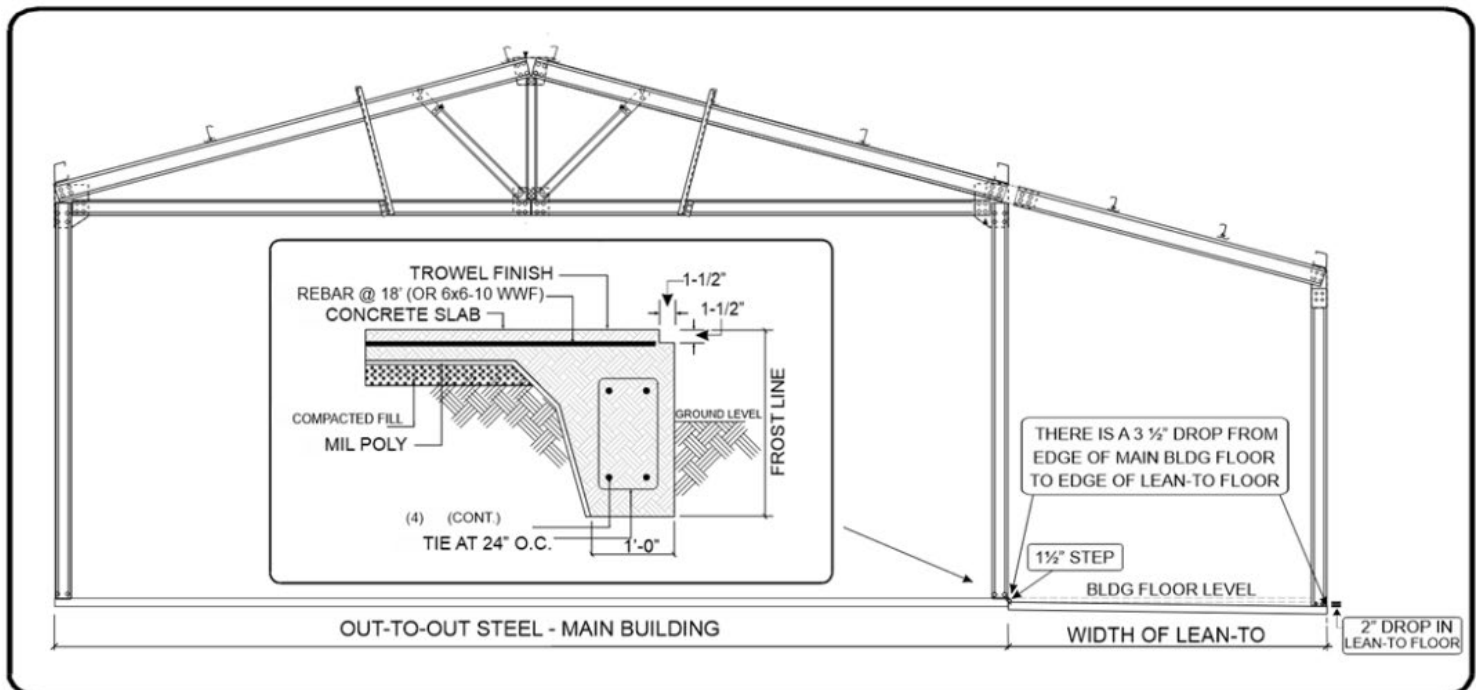

LEAN-TO FOUNDATION CONTINUED

LEAN-TO FOUNDATION SIDEWALL VIEW

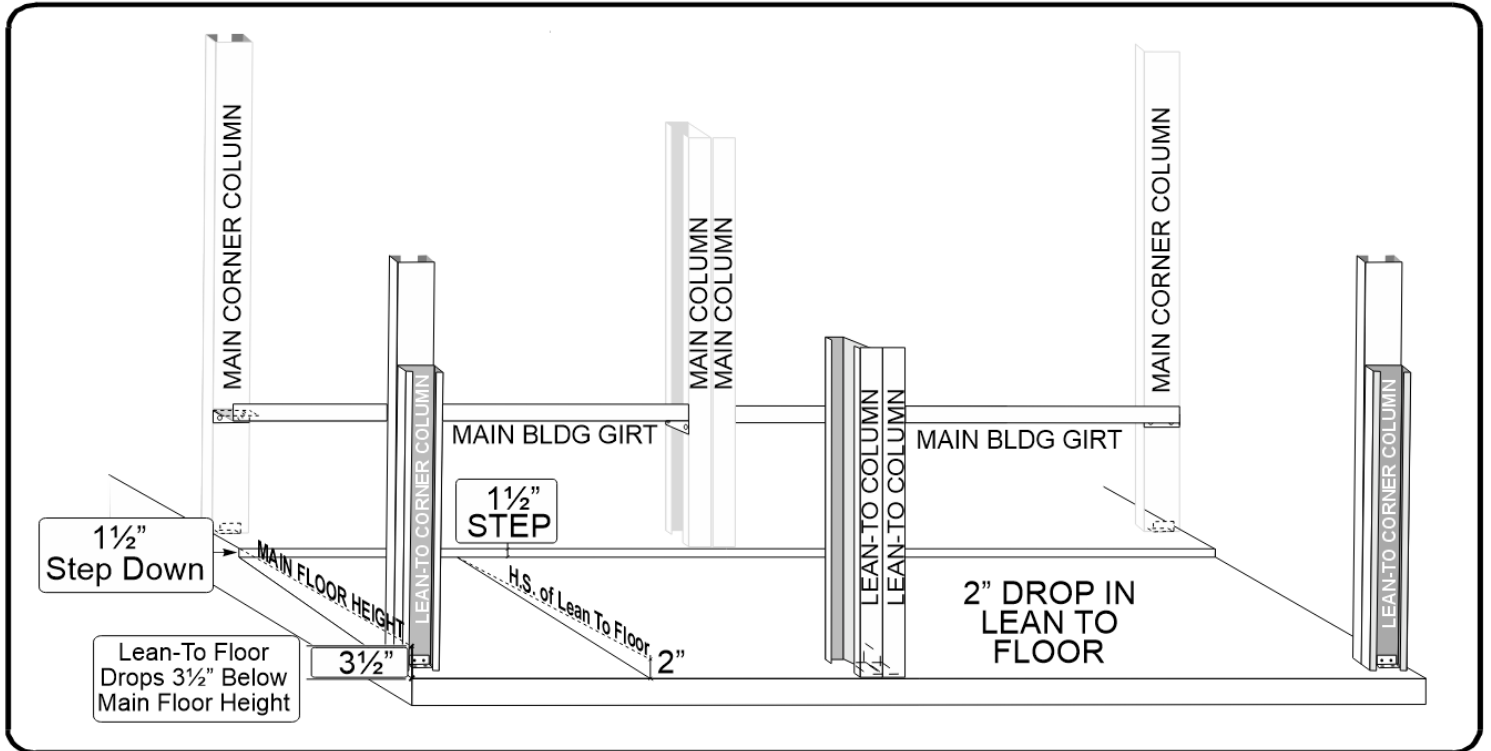

CONTINUOUS LEAN-TO AT 3:12 PITCH

BASIC CHECKLIST FOR CONTINUOUS LEAN-TO

RED IRON SECTION (SEE DETAIL BELOW)

- 1) LOCATE COLUMNS
- 2) BOLT BC-6 CLIPS TO BASE OF COLUMNS
- 3) BOLT CCCR AND CCCL CLIPS TO MAIN BUILDING AND LEAN-TO ENDWALL COLUMNS
- 4) LOCATE RAFTERS
- 5) SCREW UP-4 & UP-6 CLIPS TO RAFTERS AT LOCATIONS SPECIFIED BY FRAMING PLANS
- 6) STAND ALL COLUMNS ACCORDING TO ANCHOR BOLT LOCATIONS
IMPORTANT: PROVIDE TEMPORARY BRACING AS NEEDED TO SUFFICIENTLY BRACE THE STRUCTURE AS ERECTION PROCEEDS.
- 7) ATTACH ONE END OF LTC-1 CLIP TO MAIN ENDWALL B-1 RAFTER AND THE OTHER END OF THE LTC-1 CLIP TO THE LEAN-TO RAFTER.
- 8) ATTACH THE CORRESPONDING CORNER COLUMN CLIP SHOWN ON PLANS TO THE TOP OF THE LEAN-TO ENDWALL COLUMN. ALIGN LEAN-TO RAFTER AND CONNECT TO THE LEAN-TO ENDWALL COLUMN BY USING THE SAME CORNER COLUMN CLIP.
- 9) MOVE TO THE CLOSEST INTERIOR COLUMN NEXT TO THE NEWLY ASSEMBLED ENDWALL RAFTER
- 10) ATTACH TWO ENDS OF YOUR BACK-TO-BACK LEAN-TO INTERIOR RAFTERS TO THE MAIN BUILDING B-2 RAFTERS USING A LTC-1 CLIP
- 11) ATTACH THE OTHER END OF THE LEAN-TO INTERIOR RAFTERS TO THE TOP OF THE LEAN-TO COLUMNS USING THE SP3 CLIP.
- 12) LOCATE PURLIN(S)
- 13) CONNECT PURLIN(S) TO UP-4 AND UP-6 LOCATIONS ON LEAN-TO RAFTERS.
NOTE: IF YOUR LEAN-TO HAS AN OVERHANG REFER TO THE "STEEL TRUSS FRAME OVERHANG" SUBSECTION IN SECTION 4 FOR INSTRUCTIONS
- 14) ATTACH EAVE STRUT ONTO FIRST LEAN-TO BAY
NOTE: IF LEAN-TO HAS MORE THAN TWO BAYS, REPEAT STEPS 9 THROUGH 14.
- 15) ATTACH OPPOSITE LEAN-TO ENDWALL RAFTER
- 16) ATTACH REMAINING EAVE STRUT
- 17) ATTACH REMAINING PURLIN(S)
- 18) ATTACH GABLE ANGLE ACCORDING TO FRAMING PLANS
NOTE: SEE "RAKE/GABLE ANGLE WITH & W/O OVERHANG" FOR DETAILS

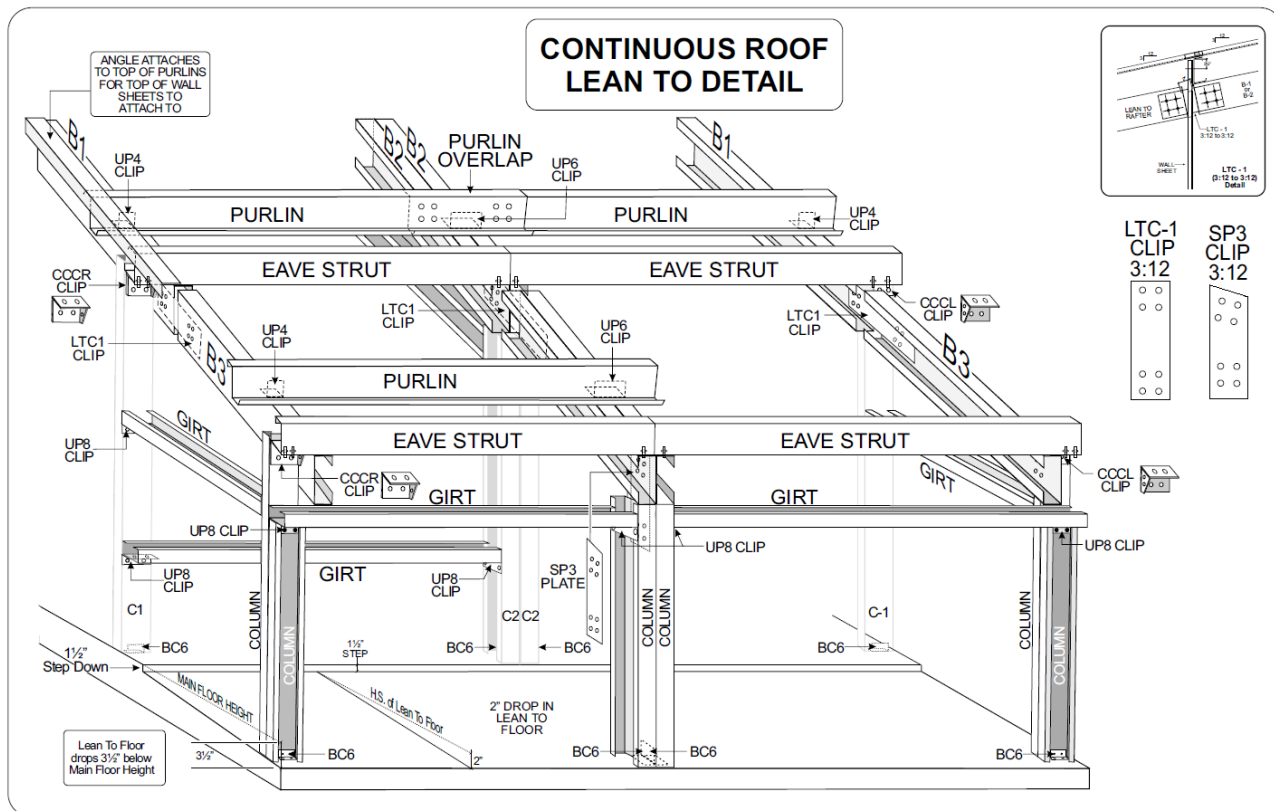

CONTINUOUS LEAN-TO AT 3:12 PITCH

BASIC CHECKLIST FOR CONTINUOUS LEAN-TO CONTINUED

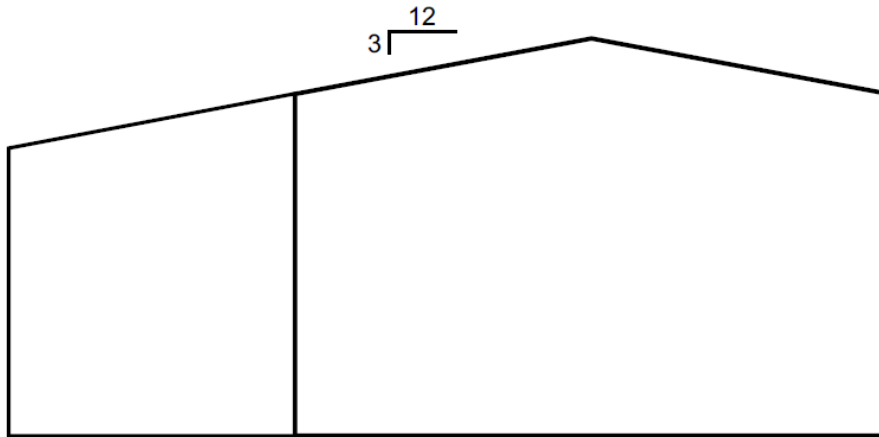

Continuous Roof - Lean To 3:12 to 3:12

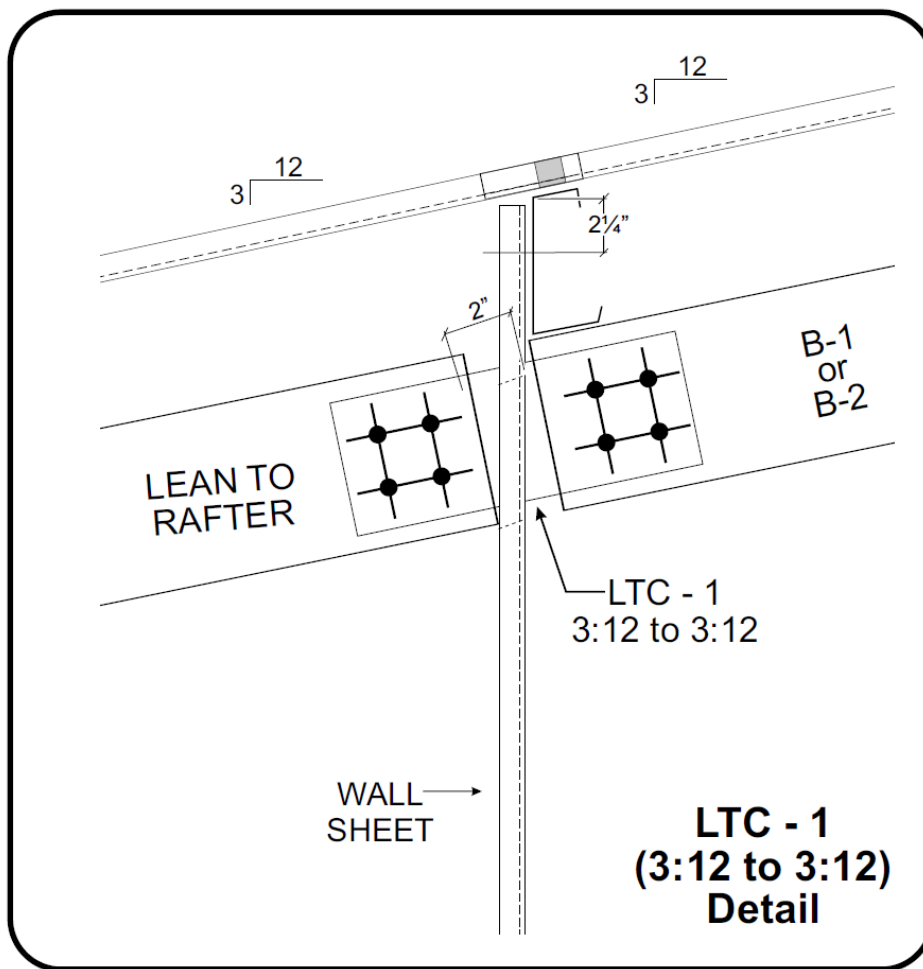

BASIC CHECKLIST FOR CONTINUOUS LEAN-TO CONTINUED

SHEET AND TRIM SECTION

NOTE: SKIP TO STEP 7 IF YOUR LEAN-TO DOES NOT REQUIRE TRIANGLE OR WALL SHEET TRIMOUT

- 1) SCREW UP-8 CLIPS TO COLUMNS AT LOCATIONS SPECIFIED BY FRAMING PLANS
- 2) LOCATE GIRTS
- 3) PLACE GIRTS AROUND PERIMETER OF LEAN-TO AT FRAMING PLAN LOCATIONS ON GROUND
- 4) SET GIRTS AT UP-8 CLIP LOCATIONS
- 5) SCREW GIRTS ONTO UP-8 CLIPS
- 6) PREDRILL WALL TRIMOUT SHEETS AND HANG SHEETS SPECIFIED BY SHEETING PLAN
- 7) INSTALL CORNER TRIM. THIS WILL BE CUT OFF AT THE INTERSECTION OF THE TRIMOUT. ALTERNATIVELY, IT CAN BE NOTCHED AT THE TRIMOUT AND ALLOWED TO TRAVEL ALL THE WAY TO THE BOTTOM OF THE ROOF (RAKE TRIM)
- 8) INSTALL EAVE TRIM
- 9) PREDRILL ROOF SHEETS AND HANG SHEETS SPECIFIED BY SHEETING PLAN
- 10) HANG GUTTER (IF PURCHASED)
- 11) HANG CORNER BOXES (IF PURCHASED GUTTER)

CONTINUOUS ROOF LEAN-TO WITHOUT TRIMOUT

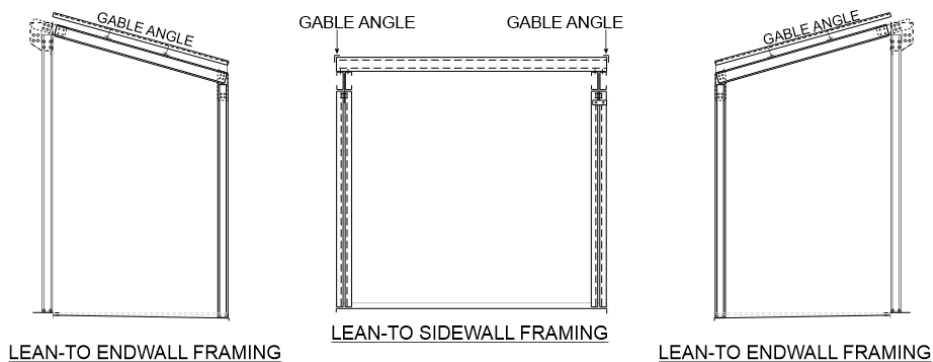

CONTINUOUS ROOF LEAN-TO FRAMING BEFORE TRIMOUT

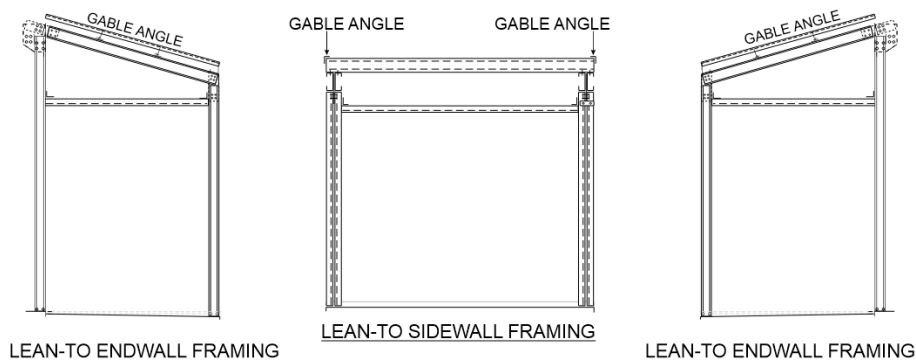

CONTINUOUS ROOF LEAN-TO WITH TRIMOUT

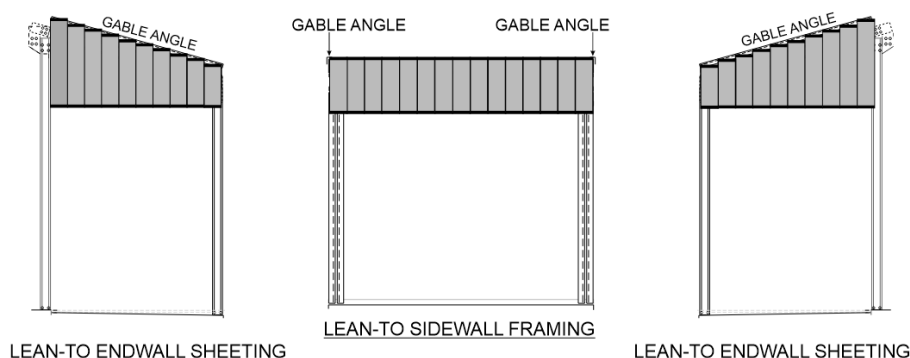

**BASIC CHECKLIST FOR OFF EAVE LEAN-TO
CONTINUED**

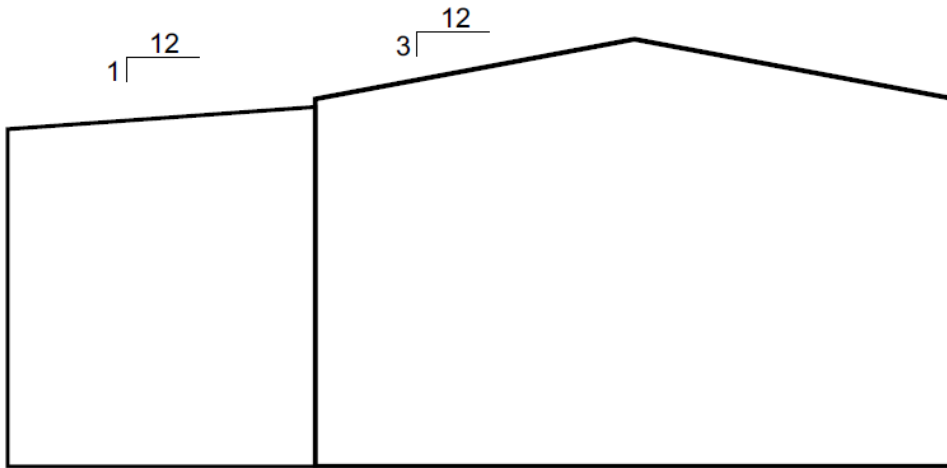

1:12 Lean To - Off Eave
3:12 to 1:12

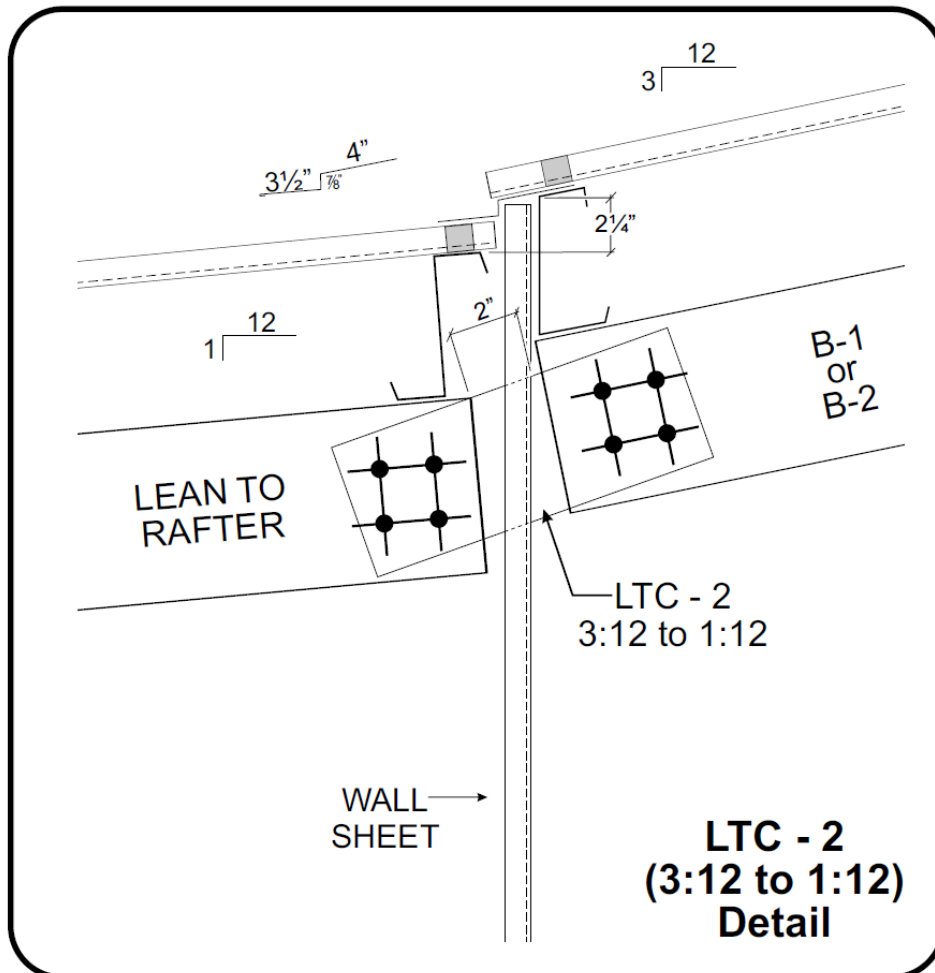

BASIC CHECKLIST FOR OFF EAVE LEAN-TO CONTINUED

SHEET AND TRIM SECTION

NOTE: SKIP TO STEP 7 IF YOUR LEAN-TO DOES NOT REQUIRE TRIANGLE OR WALL SHEET TRIMOUT

- 1) SCREW UP-8 CLIPS TO COLUMNS AT LOCATIONS SPECIFIED BY FRAMING PLANS
- 2) LOCATE GIRTS
- 3) PLACE GIRTS AROUND PERIMETER OF LEAN-TO AT FRAMING PLAN LOCATIONS ON GROUND
- 4) SET GIRTS AT UP-8 CLIP LOCATIONS
- 5) SCREW GIRTS ONTO UP-8 CLIPS
- 6) PREDRILL LEAN-TO WALL TRIMOUT SHEETS AND HANG SHEETS SPECIFIED BY SHEETING PLAN
- 7) INSTALL CORNER TRIM. THIS WILL BE CUT OFF AT THE INTERSECTION OF THE TRIMOUT. ALTERNATIVELY, IT CAN BE NOTCHED AT THE TRIMOUT AND ALLOWED TO TRAVEL ALL THE WAY TO THE BOTTOM OF THE ROOF (RAKE TRIM)
- 8) INSTALL EAVE TRIM. THERE IS AN ADDITIONAL TRANSITION TRIM THAT MUST BE INSTALLED UNDER THE MAIN BUILDING ROOF EDGE AND THE TOP OF THE LEAN-TO ROOF SHEETS.
- 9) PREDRILL ROOF SHEETS AND HANG SHEETS SPECIFIED BY SHEETING PLAN
- 10) HANG GUTTER (IF PURCHASED)
- 11) HANG CORNER BOXES (IF PURCHASED GUTTER)

OFF EAVE ROOF LEAN-TO WITHOUT TRIMOUT

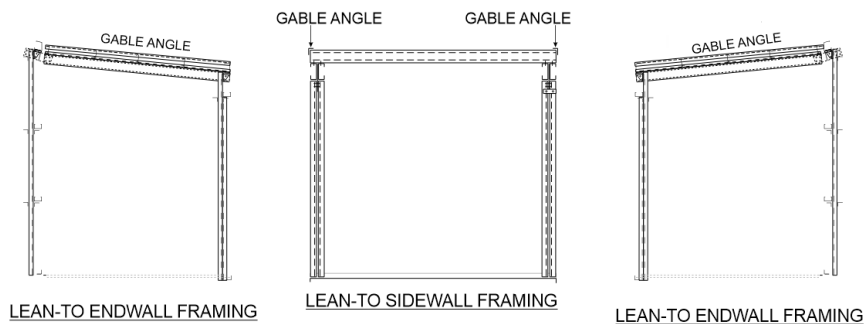

OFF EAVE ROOF LEAN-TO FRAMING BEFORE TRIMOUT

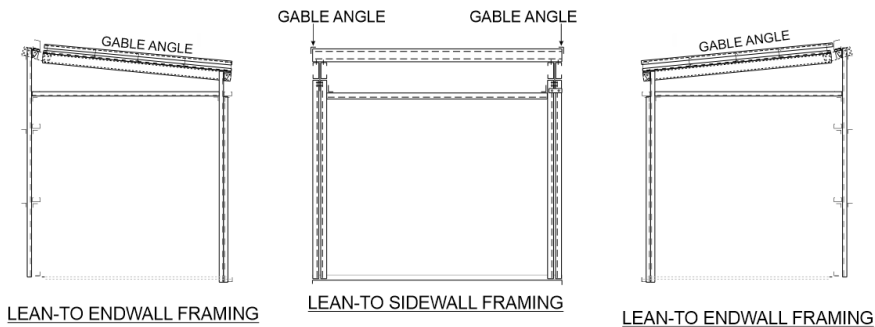

OFF EAVE ROOF LEAN-TO WITH TRIMOUT

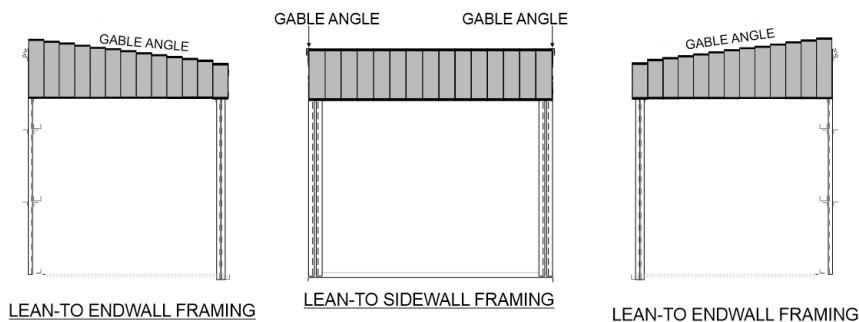

UNDER EAVE LEAN-TO

BASIC CHECKLIST FOR UNDER EAVE LEAN-TO

RED IRON SECTION (SEE DETAIL BELOW)

- 1) LOCATE COLUMNS
- 2) BOLT BC-6 CLIPS TO BASE OF COLUMNS
- 3) BOLT CCCR AND CCCL CLIPS TO TOP OF LEAN-TO ENDWALL COLUMNS
- 4) LOCATE RAFTERS
- 5) SCREW UP-4 & UP-6 CLIPS TO RAFTERS AT LOCATIONS SPECIFIED BY FRAMING PLANS
- 6) STAND ALL COLUMNS ACCORDING TO ANCHOR BOLT LOCATIONS
IMPORTANT: PROVIDE TEMPORARY BRACING AS NEEDED TO SUFFICIENTLY BRACE THE STRUCTURE AS ERECTION PROCEEDS.
- 7) DRILL HOLES AT DESIGNATED LOCATIONS ON MAIN BUILDING COLUMNS. THEN CONNECT LTC-3 OR LTC-4 CLIPS TO THE MAIN BUILDING COLUMN.
NOTE: THE MAIN BUILDING COLUMN YOU ARE CONNECTING EACH RAFTER TO DICTATES WHICH STYLE LTC CLIP YOU WILL USE. REFER TO YOUR FRAMING PLAN FOR DETAILS
- 8) START BY CONNECTING ONE END OF THE LEAN-TO ENDWALL RAFTER TO THE LTC-4 CLIP THAT IS ALREADY ATTACHED TO THE MAIN BUILDING C-1 COLUMN.
- 9) ATTACH OTHER END OF LEAN-TO ENDWALL RAFTER TO THE LEAN-TO CORNER COLUMN CLIP ON THE TOP OF THE ADJACENT LEAN-TO ENDWALL COLUMN.
- 10) MOVE TO THE CLOSEST INTERIOR COLUMN NEXT TO THE NEWLY ASSEMBLED ENDWALL RAFTER
- 11) CONNECT ONE END OF THE LEAN-TO INTERIOR RAFTER TO THE LTC-3 CLIP THAT IS ALREADY ATTACHED TO THE MAIN BUILDING C-2 COLUMN
- 12) ATTACH THE OTHER END OF THE LEAN-TO INTERIOR RAFTERS TO THE TOP OF THE LEAN-TO COLUMNS USING THE SP3 OR SP1 CLIP SPECIFIED ON FRAMING PLANS.
- 13) LOCATE PURLIN(S)
- 14) CONNECT PURLIN(S) TO UP-4 AND UP-6 LOCATIONS ON LEAN-TO RAFTERS.
NOTE: IF YOUR LEAN-TO HAS AN OVERHANG REFER TO THE "STEEL TRUSS FRAME OVERHANG" SUBSECTION IN SECTION 4 FOR INSTRUCTIONS
- 15) ATTACH EAVE STRUT ONTO FIRST LEAN-TO BAY
NOTE: IF LEAN-TO HAS MORE THAN TWO BAYS, REPEAT STEPS 10 THROUGH 15.
- 16) ATTACH OPPOSITE LEAN-TO ENDWALL RAFTER USING STEPS 8 & 9.
- 17) ATTACH REMAINING EAVE STRUT
- 18) ATTACH REMAINING PURLIN(S)
- 19) ATTACH GABLE ANGLE ACCORDING TO FRAMING PLANS
NOTE: SEE "RAKE/GABLE ANGLE WITH & W/O OVERHANG" FOR DETAILS

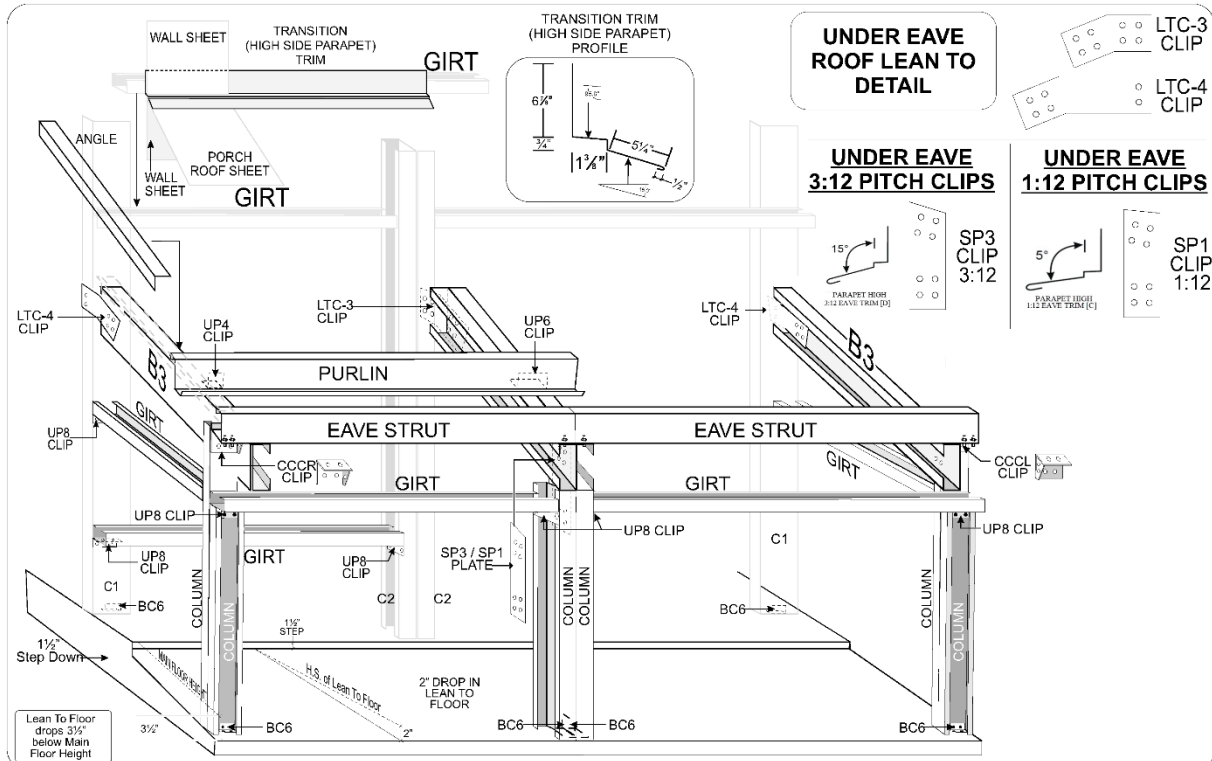

**BASIC CHECKLIST FOR UNDER EAVE LEAN-TO
CONTINUED**

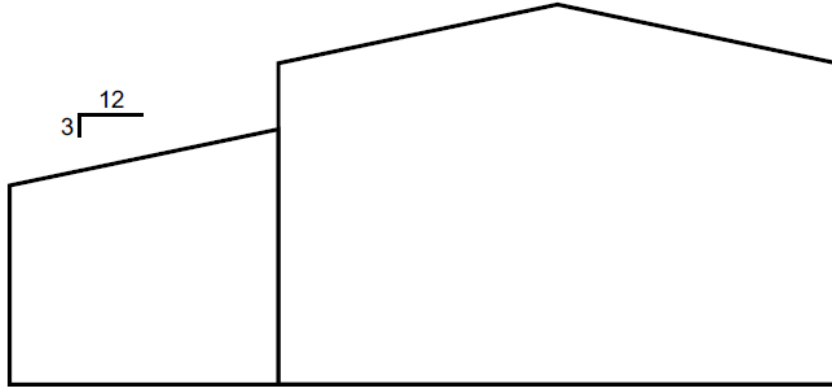

**Endwall Corner Column
To Under Eave Lean To
3:12 Pitch**

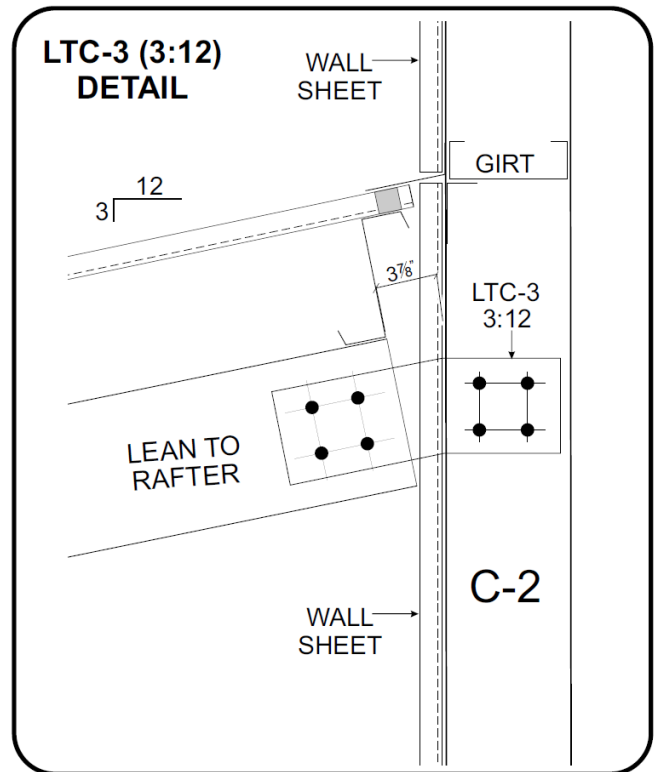
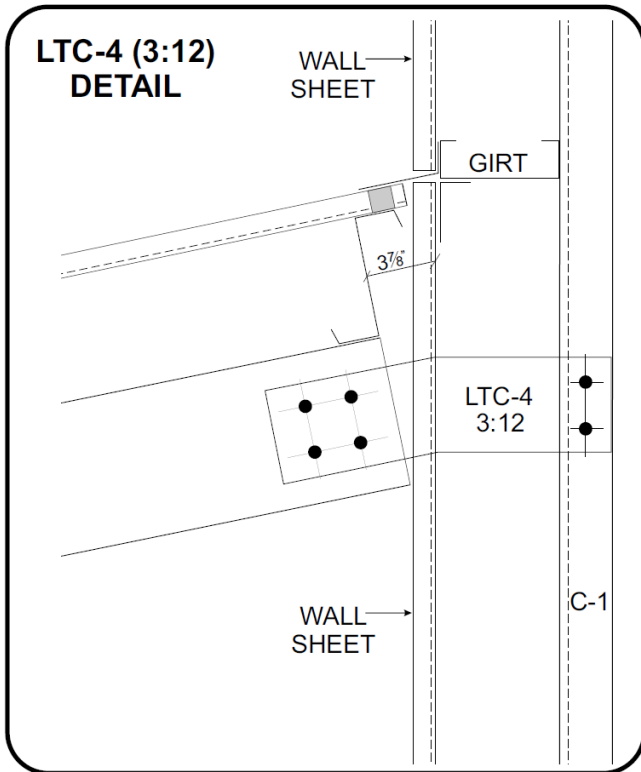

**BASIC CHECKLIST FOR UNDER EAVE LEAN-TO
CONTINUED**

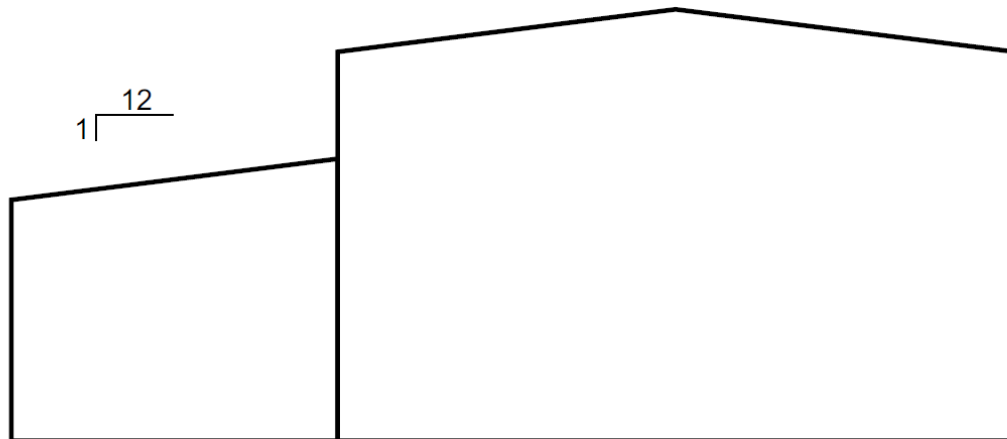

**Endwall Corner Column
To Under Eave Lean To
1:12 Pitch**

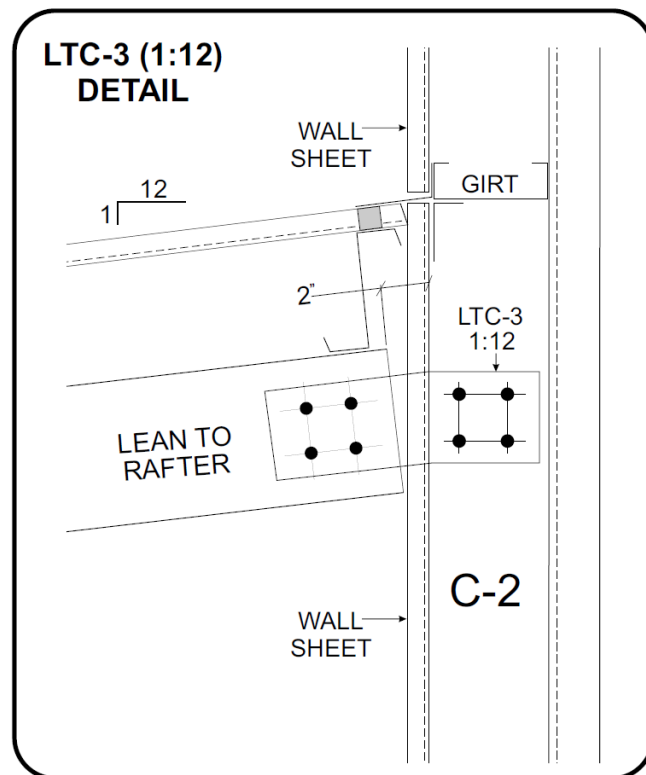
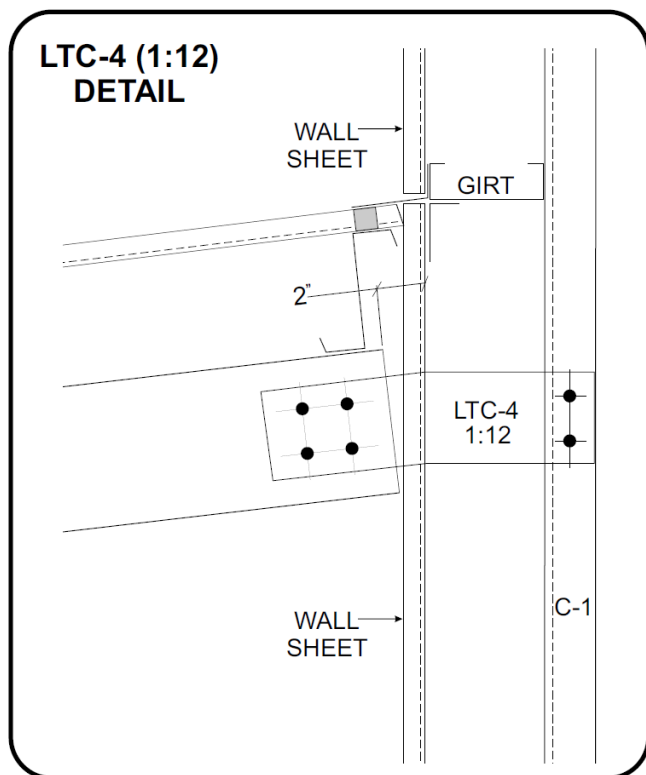

BASIC CHECKLIST FOR UNDER EAVE LEAN-TO CONTINUED

SHEET AND TRIM SECTION

NOTE: SKIP TO STEP 7 IF YOUR LEAN-TO DOES NOT REQUIRE TRIANGLE OR WALL SHEET TRIMOUT

- 1) SCREW UP-8 CLIPS TO COLUMNS AT LOCATIONS SPECIFIED BY FRAMING PLANS
- 2) LOCATE GIRTS
- 3) PLACE GIRTS AROUND PERIMETER OF LEAN-TO AT FRAMING PLAN LOCATIONS ON GROUND
- 4) SET GIRTS AT UP-8 CLIP LOCATIONS
- 5) SCREW GIRTS ONTO UP-8 CLIPS
NOTE: THERE IS AN EXTRA GIRT AND ANGLE REQUIRED IN THE MAIN BUILDING WALL. THIS ALLOWS FOR THE ATTACHMENT OF THE SHEETING WHERE IT SPLITS AROUND THE TRANSITION TRIM.
- 6) PREDRILL LEAN-TO WALL TRIMOUT SHEETS AND HANG LEAN-TO SHEETS SPECIFIED BY SHEETING PLAN
- 7) INSTALL EAVE TRIM
- 8) PREDRILL LEAN-TO ROOF SHEETS AND HANG LEAN-TO SHEETS SPECIFIED BY SHEETING PLAN
- 9) INSTALL EXTERIOR CORNER TRIM (CORNER TRIM THAT TRANSITIONS LEAN-TO ENDWALL TO LEAN-TO SIDEWALL SHEETS). THIS WILL BE CUT OFF AT THE INTERSECTION OF THE TRIMOUT. THE NOTCH WILL GO AROUND THE LEAN-TO PORTION AND LEAVE FULL CORNER TRIM ABOVE AND BELOW THE LEAN-TO.
- 10) ATTACH EITHER PARAPET HIGH 3:12 EAVE TRIM [D] OR PARAPET HIGH 1:12 EAVE TRIM [C] & WALL CLOSURES SPECIFIED ON FRAMING PLAN TO MERGE MAIN WALL SHEETING AND LEAN-TO ROOF SHEETING.
- 11) PREDRILL MAIN BUILDING UPPER WALL SHEETS AND HANG MAIN BUILDING UPPER WALL SHEETS SPECIFIED BY SHEETING PLAN
NOTE: A SLIT WILL NEED TO BE FIELD CUT THROUGH THE MAIN BUILDING WALL SHEET TO ALLOW THE LTC-3 OR LTC-4 CLIP TO PASS THROUGH. CLIENT SHOULD CAULK ANYWHERE THAT MAY BE SUSCEPTIBLE TO LEAKS – FOR INSTANCE, AT THE END OF THE TRANSITION TRIM WHERE IT IS MEETING UP WITH THE CORNER TRIM, SLITS IN WALL PANEL WHERE LTC CLIPS ARE USED, ETC.
- 12) PREDRILL MAIN BUILDING LOWER WALL SHEETS AND HANG MAIN BUILDING LOWER WALL SHEETS SPECIFIED BY SHEETING PLAN.
NOTE: A SLIT WILL NEED TO BE FIELD CUT THROUGH THE MAIN BUILDING WALL SHEET TO ALLOW THE LTC-3 OR LTC-4 CLIP TO PASS THROUGH.
- 13) INSTALL INTERIOR CORNER TRIM (CORNER TRIM THAT TRANSITIONS MAIN WALL TO LEAN-TO WALL SHEETS). THIS WILL BE CUT OFF AT THE INTERSECTION OF THE TRIMOUT.
- 14) HANG GUTTER (IF PURCHASED)
- 15) HANG CORNER BOXES (IF PURCHASED GUTTER)

UNDER EAVE LEAN-TO

BASIC CHECKLIST FOR UNDER EAVE LEAN-TO CONTINUED

SHEET AND TRIM SECTION VISUAL AID

UNDER EAVE ROOF LEAN-TO WITHOUT TRIMOUT

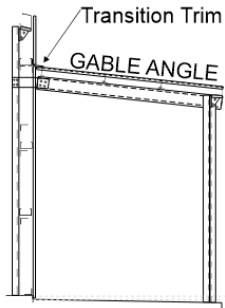

LEAN-TO ENDWALL FRAMING

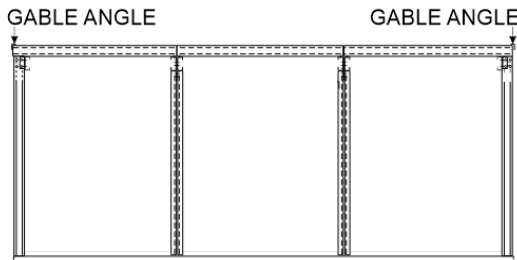

LEAN-TO SIDEWALL FRAMING

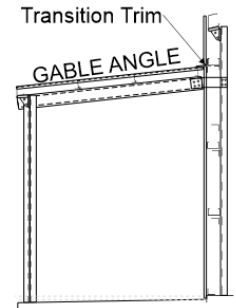

LEAN-TO ENDWALL FRAMING

UNDER EAVE ROOF LEAN-TO FRAMING BEFORE TRIMOUT

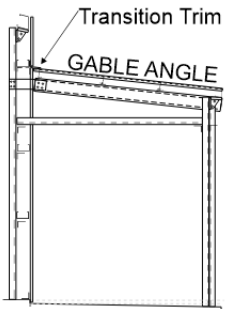

LEAN-TO ENDWALL FRAMING

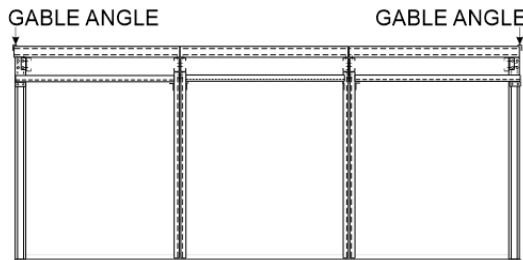

LEAN-TO SIDEWALL FRAMING

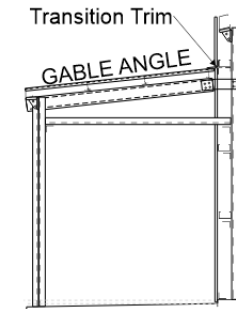

LEAN-TO ENDWALL FRAMING

UNDER EAVE ROOF LEAN-TO WITH TRIMOUT

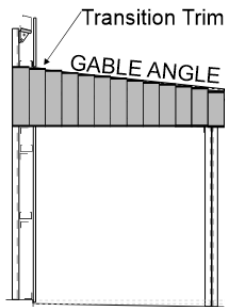

LEAN-TO ENDWALL FRAMING

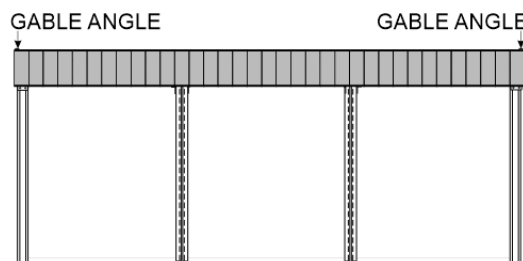

LEAN-TO SIDEWALL FRAMING

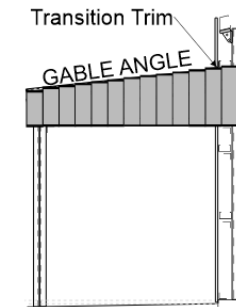

LEAN-TO ENDWALL FRAMING

BASIC CHECKLIST FOR WRAP AROUND PORCH AT 3:12 PITCH

RED IRON SECTION UP TO THE CORNER DETAIL (SEE DETAIL BELOW)

- 1) LOCATE COLUMNS
- 2) BOLT BC-6 CLIPS TO BASE OF COLUMNS
- 3) LOCATE RAFTERS AND SCREW UP-4 & UP-6 CLIPS TO RAFTERS AT LOCATIONS SPECIFIED BY FRAMING PLANS
- 4) STAND ALL COLUMNS ACCORDING TO ANCHOR BOLT LOCATIONS
IMPORTANT: PROVIDE TEMPORARY BRACING AS NEEDED TO SUFFICIENTLY BRACE THE STRUCTURE AS ERECTION PROCEEDS.
- 5) DRILL HOLES AT DESIGNATED LOCATIONS ON MAIN BUILDING COLUMNS. THEN CONNECT LTC-3 OR LTC-4 CLIPS TO THE MAIN BUILDING COLUMN.
NOTE: THE MAIN BUILDING COLUMN YOU ARE CONNECTING EACH RAFTER TO DICTATES WHICH STYLE LTC CLIP YOU WILL USE. REFER TO YOUR FRAMING PLAN FOR DETAILS.
- 6) START BY CONNECTING ONE END OF THE WRAP AROUND PORCH ENDWALL RAFTER TO THE LTC-3 OR LTC-4 CLIP THAT IS ALREADY ATTACHED TO THE STARTING MAIN BUILDING COLUMN.
- 7) ATTACH OTHER END OF WRAP AROUND PORCH ENDWALL RAFTER TO THE ADJACENT WRAP AROUND PORCH ENDWALL COLUMN WITH A SP3 CLIP OR CORNER COLUMN CLIP SPECIFIED IN FRAMING PLANS.
- 8) MOVE TO THE CLOSEST INTERIOR COLUMN NEXT TO THE NEWLY ASSEMBLED ENDWALL RAFTER
- 9) CONNECT ONE END OF THE WRAP AROUND PORCH INTERIOR RAFTER TO THE LTC-3 CLIP THAT IS ALREADY ATTACHED TO THE MAIN BUILDING COLUMN
- 10) ATTACH THE OTHER END OF THE WRAP AROUND PORCH INTERIOR RAFTERS TO THE TOP OF THE WRAP AROUND PORCH COLUMNS USING THE SP3 CLIP.
- 11) LOCATE PURLIN(S)
- 12) CONNECT PURLIN(S) TO UP-4 AND UP-6 LOCATIONS ON WRAP AROUND PORCH RAFTERS
- 13) ATTACH EAVE STRUT ONTO FIRST WRAP AROUND PORCH BAY
- 14) REPEAT STEPS 8 THROUGH 13 UNTIL YOU ARRIVE AND COMPLETE THE RAFTER ASSEMBLY THAT CONNECTS TO THE MAIN BUILDING'S SIDEWALL C1 CORNER COLUMN.
- 15) NOW, MOVE TO THE WRAP AROUND PORCH ENDWALL THAT IS ON THE MAIN BUILDING'S ENDWALL.
- 16) REPEAT STEPS 6 THROUGH 13 UNTIL YOU ARRIVE AND COMPLETE THE RAFTER ASSEMBLY THAT CONNECTS TO THE MAIN BUILDING'S ENDWALL C1 COLUMN.
NOTE: THIS WILL BE THE SAME COLUMN THAT YOU STOPPED AT EARLIER FOR THE SIDEWALL PORTION OF THE WRAP AROUND PORCH.
- 17) YOU ARE NOW READY TO MERGE THE TWO LEAN-TO'S VIA THE HIP RAFTER CONNECTION. FOLLOW STEPS ON NEXT PAGE FOR THOSE STEPS.

WRAP AROUND PORCH AT 3:12 PITCH

BASIC CHECKLIST FOR WRAP AROUND PORCH CONTINUED

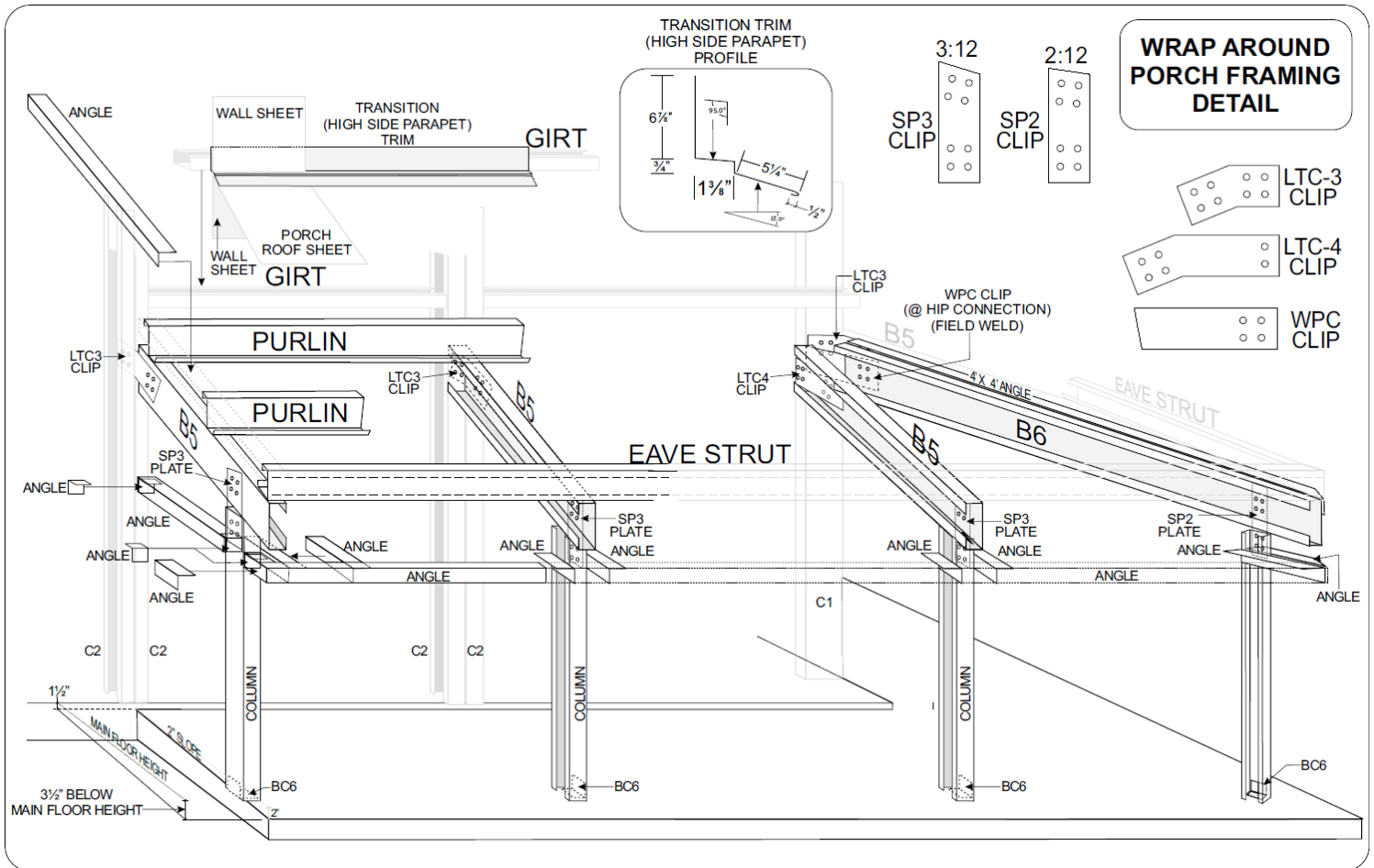

BASIC CHECKLIST FOR WRAP AROUND PORCH AT 3:12 PITCH CONTINUED

SHEET AND TRIM SECTION

- 1) FIELD CUT 4X2 SUPPORT ANGLES THAT ATTACH TO LEAN-TO COLUMNS.
- 2) ATTACH 4X2 SUPPORT ANGLES TO THE LEAN-TO COLUMNS AS SHOWN ON FRAMING PLANS
- 3) PLACE LONGER 4X2 ANGLE AROUND PERIMETER OF WRAP AROUND PORCH AT FRAMING PLAN LOCATIONS ON GROUND. THIS ANGLE IS USED TO ATTACH THE BOTTOM OF THE LEAN-TO SHEETING
- 4) SET 4X2 ANGLE BEAMS ON 4X2 SUPPORT ANGLE LOCATIONS
- 5) SCREW 4X2 ANGLE BEAMS ONTO 4X2 SUPPORT ANGLES AT CORRECT ORIENTATION SHOWN ON PLANS. *NOTE: THERE IS AN EXTRA GIRT AND ANGLE REQUIRED IN THE MAIN BUILDING WALL. THIS ALLOWS FOR THE ATTACHMENT OF THE SHEETING WHERE IT SPLITS AROUND THE TRANSITION TRIM.*
- 6) PREDRILL LEAN-TO WALL TRIMOUT SHEETS AND HANG LEAN-TO SHEETS SPECIFIED BY SHEETING PLAN
- 7) INSTALL SOFFIT CAP
- 8) INSTALL EAVE TRIM
- 9) PREDRILL LEAN-TO ROOF SHEETS AND HANG LEAN-TO SHEETS SPECIFIED BY SHEETING PLAN
- 10) INSTALL EXTERIOR CORNER TRIM (CORNER TRIM THAT TRANSITIONS LEAN-TO ENDWALL TO LEAN-TO SIDEWALL SHEETS). THIS WILL BE CUT OFF AT THE INTERSECTION OF THE TRIMOUT. THE NOTCH WILL GO AROUND THE LEAN-TO PORTION AND LEAVE FULL CORNER TRIM ABOVE AND BELOW THE LEAN-TO.
- 11) ATTACH PARAPET HIGH 3:12 EAVE TRIM [D] SPECIFIED ON FRAMING PLAN TO MERGE MAIN WALL SHEETING AND LEAN-TO ROOF SHEETING.
- 12) PREDRILL MAIN BUILDING UPPER WALL SHEETS AND HANG MAIN BUILDING UPPER WALL SHEETS SPECIFIED BY SHEETING PLAN. *NOTE: CLIENT SHOULD CAULK ANYWHERE THAT MAY BE SUSCEPTIBLE TO LEAKS – FOR INSTANCE, AT THE END OF THE TRANSITION TRIM WHERE IT IS MEETING UP WITH THE CORNER TRIM, SLITS IN WALL PANEL WHERE LTC CLIPS ARE USED, ETC.*
- 13) PREDRILL MAIN BUILDING LOWER WALL SHEETS AND HANG MAIN BUILDING LOWER WALL SHEETS SPECIFIED BY SHEETING PLAN
- 14) INSTALL INTERIOR CORNER TRIM (CORNER TRIM THAT TRANSITIONS MAIN WALL TO LEAN-TO WALL SHEETS). THIS WILL BE CUT OFF AT THE INTERSECTION OF THE TRIMOUT.
- 15) INSTALL HEAD TRIM FOR SOFFIT AT BUILDING
- 16) INSTALL SOFFIT PANEL (REVERSE RUN 'R' PANEL)
- 17) HANG GUTTER (IF PURCHASED)
- 18) HANG CORNER BOXES (IF PURCHASED GUTTER)

WRAP AROUND PORCH AT 3:12 PITCH

BASIC CHECKLIST FOR WRAP AROUND PORCH AT 3:12 PITCH PITCH CONTINUED

UNDER EAVE ROOF LEAN-TO FRAMING BEFORE TRIMOUT

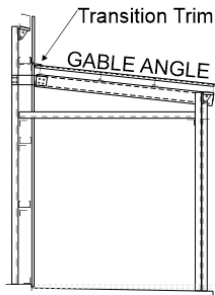

LEAN-TO ENDWALL FRAMING

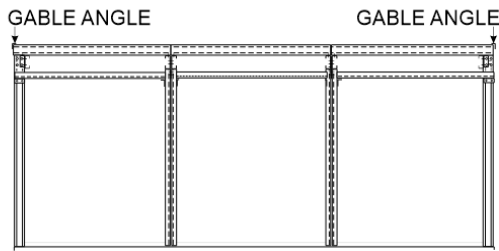

LEAN-TO SIDEWALL FRAMING

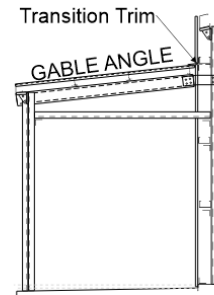

LEAN-TO ENDWALL FRAMING

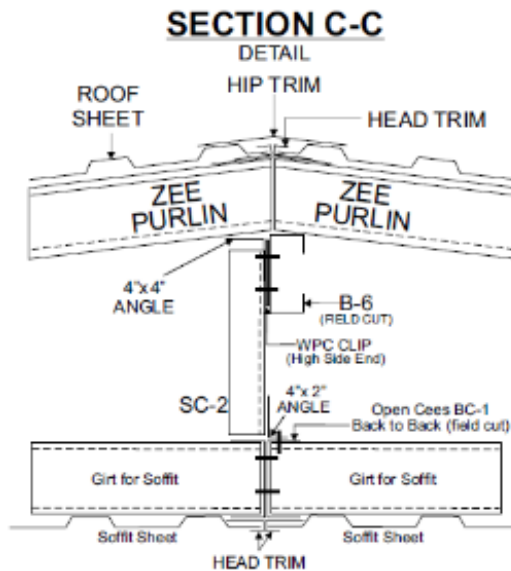

UNDER EAVE ROOF LEAN-TO WITH TRIMOUT

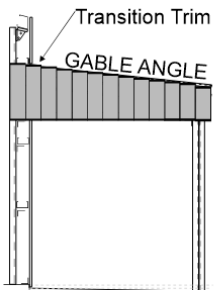

LEAN-TO ENDWALL FRAMING

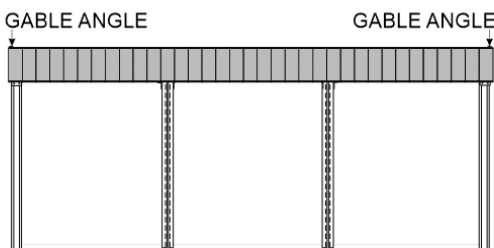

LEAN-TO SIDEWALL FRAMING

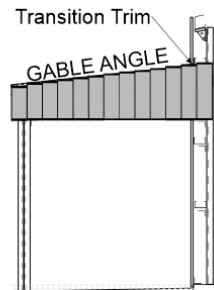

LEAN-TO ENDWALL FRAMING